

IWAKI Metering Pump

AX Series (Plunger type)

Instruction Manual

 Read this manual before use of product

Thank you for selecting the Iwaki metering pump AX type.
This instruction manual describes the correct handling of the pump, maintenance and inspection procedures, and troubleshooting. You are requested to go through this manual, in order to make maximum use of the pump for a long period of time. After reading it, please keep the manual in a prominent place for ready reference.

Contents

| ■Item | ■Page |
|--|-------|
| Important instructions. | 1 |
| Safety instructions | 2 |
| 1. Unpacking and Inspection | 5 |
| 2. Principle of Operation | 6 |
| 3. Identification Codes. | 7 |
| 4. Specifications (Outline) | 10 |
| 5. Description of Pump Mechanism & Points to Note During Operation. | 13 |
| 6. Installation, Piping and Wiring | 15 |
| 7. Operation. | 19 |
| 8. Maintenance and Inspection | 25 |
| 9. Troubleshooting Guide | 28 |
| 10. Disassembly, Reassembly and Assembly. | 29 |
| 11. Normal Consumable Parts. | 34 |
| 12. Parts Description and Exploded View. | 36 |



Export Restrictions

Technical information contained in this instruction manual might be treated as controlled technology in your countries, due to agreements in international regime for export control. Please be reminded that export license/permission could be required when this manual is provided, due to export control regulations of your country.

Important instructions

For the Safe and Correct Handling of the Pump

- "Safety Instruction" section deals with important details about handling of the product. Before use, read this section carefully for the prevention of personal injury or property damage.
- Observe the instructions accompanied with "WARNING" or "CAUTION" in this manual. These instructions are very important for protecting users from dangerous situations.
- The symbols on this instruction manual have the following meanings:

| | |
|--|--|
|  WARNING | Nonobservance or misapplication of "Warning" sections could lead to a serious accident which may result in death. |
|  CAUTION | Nonobservance or misapplication of "Caution" sections could lead to personal injury or property damage. |

Types of Symbols



Indicates that "Warning" or "Caution" must be exercised. Inside this triangle, a concrete and practical image provided as a warning or caution message is depicted.



Indicates a prohibited action or procedure. Inside or near this circle, a concrete and practical image of the activity to be avoided is depicted.



Indicates an important action or procedure which must be performed or carried out without fail. Failure to follow the instructions herein can lead to malfunction or damage to the pump.

Safety instructions

WARNING

- **Turn off power supply**

Dismantling/assembling the pump unit without turning off power supply may cause an electrical shock. Before engaging in any maintenance and inspection work, be sure to turn power supply off to stop the pump and related devices. Workers should be careful to prevent power source from turning on unintentionally during work.



Turn off power

- **Qualified operator only**

The pump must be operated/controlled by operator(s) who has trained in the safe operation of the pump.



Prohibition

- **Wear protective clothing**

Always wear protective clothing such as safety goggles and protective gloves when arranging piping or dismantling the pump.



Wear protective gear

- **Arrange grounding**

Risk of electrical shock. Do not operate the pump unit without connecting the grounding wire.



Grounding

- **Use eye bolts**

Use eye bolts to lift the pump. Otherwise the pump may break and accidentally fall down, resulting serious injury.



- **Before starting the pump**

Be sure there is no one around the pump before connecting power. The pump doesn't have a operation switch. On connection of the power, the pump starts to run.



- **Damaged pumps**

Risk of electrical shock. Do not use damaged pumps.



Prohibition

- **Do not wet the pump with solution or water**

Solution enters the pump through the air breather and corrodes oil/metallic parts, resulting in pump failure.



Safety instructions

CAUTION

- **Limited operating site and storage**

Do not install or store the pump in the following places where...

1. Ambient temperature exceeds 40°C or falls below 0°C.
2. Ambient humidity exceed 35-95%RH.
3. Under a flammable/explosive atmosphere or in a dusty/humid place.
4. Under vibration or wind & rain.



Prohibition

- **For specified application only**

The use of the pump in any application other than those clearly specified may result in injury or damage. Use the pump in a specified condition.



Prohibition

- **Do not modify the pump**

Risk of electrical shock. We are not responsible for any accidents or damage due to modification.



No modification

- **Do not step on the pump**

Do not step on the pump. Do not use the pump in place of a footstool. You may fall down from the pump and be injured.



Prohibition

- **Keep electric parts and wiring dry**

Risk of fire or electric shock. Install the pump where it can be kept dry.



Prohibition

- **Countermeasure against efflux**

Take protective measures against the accidental efflux caused by the pump or piping breakage. Do not drain chemical directory onto the ground. Disposal of harmful liquid should be done in accordance with local laws.



- **Use in a cold place**

When ambient temperature lowers below zero degrees Celsius, the pump may be broken by liquid freezing. Drain liquid from the pump and piping every time operation is completed.



- **Do not close a discharge or a suction valve during operation**

Operation with closed suction may cause malfunction of the pump. Operation with closed discharge may cause a sudden pressure rise in the pump and piping. This can break the pump and motor.



Prohibition

- **Install a relief valve**

Install a relief valve on a discharge line near the pump so as to automatically release the discharge pressure when it exceeds the maximum level.



Safety instructions

CAUTION

- **Do not remove the Bracket cover**

Never remove the Bracket cover during operation. Touching the plunger when it is rotating, serious injury may result.



- **Pump disposal**

Dispose of any used or damaged pump in accordance with local laws and regulations. Consult a licensed industrial waste products disposing company.



- **Pump structure**

This pump is designed and manufactured according to Electricity Enterprises Law of Japan.



Caution

1. Unpacking and inspection

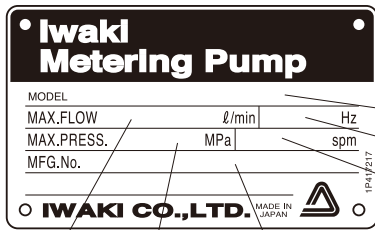

Model
 Frequency
 Number of strokes
 Discharge
 Discharge pressure
 Manufacturing No.

After unpacking the pump, check the following points to confirm that the product conforms to your order. If you find anything wrong, please contact the dealer with whom you placed the order.

1 Do the model, discharge pressure, stroke number, and other details on the nameplate correspond to those of the pump you ordered?

2 Does the package contain the following accessories?

- ① Air breathers 1
- ② Gland nut setting tool 1
- ③ Plunger nut setting tool 1

3 Has the pump been damaged, or nuts and bolts been loosened, during delivery?

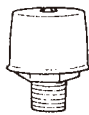

Air breather



Plunger nut setting tool



Gland nut setting tool

2. Principle of operation

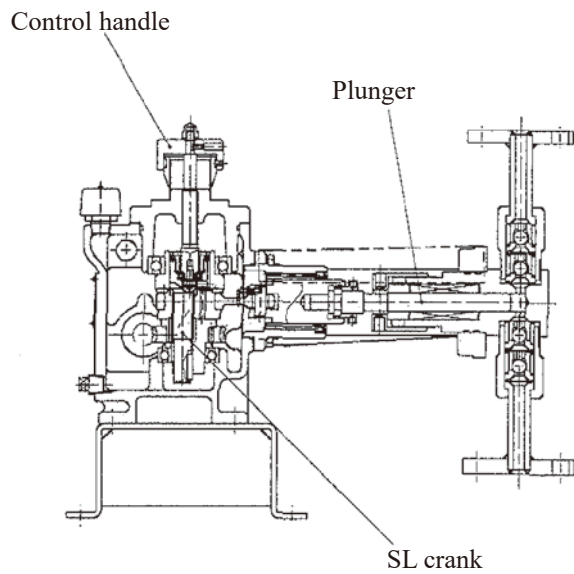

The Iwaki metering pump AX-series has a driving unit that employs an SL crank mechanism, and is designed for chemical processing.

The gear reducer slows the motor speed, and the SL crank mechanism converts rotation to reciprocating motion, which is transmitted to the plunger to operate the pump.

The discharge is adjusted when a control handle is rotated to change the length of stroke.

3. Identification codes

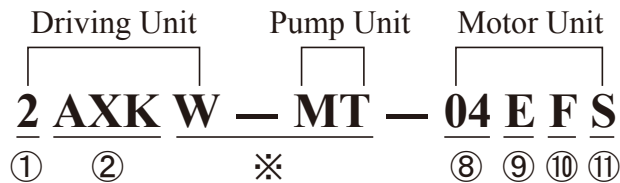
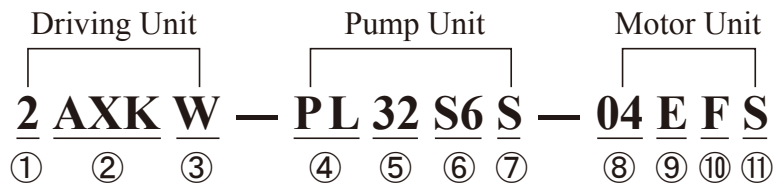

① Serial-use model code

Without symbol 1: Single-use pump

2: Dual (or multiple)-use pump

(Indicated for models to be used in series of two or more pumps)

② Driving unit model code

| Mode | Stroke Length (at 100% stroke) | Standard Motor Output |
|------|-----------------------------------|-----------------------|
| AXJ | 15 mm | 0.2 kW |
| AXK | 24 mm | 0.4 kW |
| AXA | 30 mm | 0.75 kW |
| AXB | 40 mm | 1.5 kW |

③ Reduction code

| Reduction Code | Reduction Ratio | Stroke Rate (50/60 Hz) |
|----------------|-----------------|------------------------|
| G | 1/30 | 48/58 spm |
| W | 1/20 | 72/86 spm |
| H | 1/15 | 96/116 spm |
| R | 1/12 | 120/- spm (50 Hz only) |

④ Pump head code

| Code | Max. Discharge Pressure |
|------|--|
| PL | 5 MPa {50 kgf/cm ² } or below |
| PH | 5 MPa {50 kgf/cm ² } to 20 MPa {200 kgf/cm ² } |
| PU | Above 20 MPa {200 kgf/cm ² } |

⑤ Diameter of plunger : The figures represent plunger diameter in mm.
5mm is written as 05 and 8mm as 08.

⑥ Material code : For details, see the table of materials in the reference data.

| Code | Material of Liquid-Contacting Parts |
|------|-------------------------------------|
| S6 | SUS316 |
| S4 | SUS304 |
| TI | Titanium |
| CA | Carpenter 20 |

⑦ Custom pump

N : For nuclear power (specially controlled, e.g., control on material history)

G : Material approved for use with high-pressure gas

S : Non-standard material

Special valves

V : High-viscosity valve

⑧ Motor output

| Code | Output |
|------|---------|
| 02 | 0.2 kW |
| 04 | 0.4 kW |
| 07 | 0.75 kW |
| 15 | 1.5 kW |
| 22 | 2.2 kW |

⑨ Stroke length adjustment

| Code | Stroke Adjusting Method |
|--------------|---------------------------------|
| Without code | Manual |
| E | Electric servo |
| A | Air servo (with A-A positioner) |
| D | Air servo (with E-A positioner) |

⑩ RPM control

| Code | RPM Control |
|----------------|-------------|
| Without symbol | Fixed rpm |
| F | Inverter |
| V | VS motor |

⑪ Motor unit made to order

S : Special base

Pulse generator

Other special specifications of the driving unit and motor unit

※ Code for multiple connection of different types of pumps

| | |
|------|---|
| W-MT | Connected pumps have the same driving unit but different types of pump heads. |
| -MT | Driving units have different reduction ratios. |

○ When pumps with different types of driving units are connected, one which has the largest output is indicated in ②.

4. Specifications (Outline)

■ Outline of Standard Specifications (Single Type)

| Model | Plunger diameter φmm | Stroke Length mm | Discharge L/min (at spm) | | | | | | | Maximum discharge pressure MPa | Standard Motor kW |
|-------|-------------------------|---------------------|--------------------------|--------|--------|-------|-----------------------|--------|---------|--------------------------------|-------------------|
| | | | 50 Hz Stroke rate spm | | | | 60 Hz Stroke rate spm | | | | |
| | | | G : 48 | W : 72 | H : 96 | R:120 | G : 58 | W : 86 | H : 116 | | |
| AXJ- | 5 | 0-15 | 0.012 | 0.019 | 0.025 | 0.031 | 0.015 | 0.023 | 0.030 | 10.0 | 0.2 |
| | 8 | | 0.032 | 0.048 | 0.065 | 0.081 | 0.039 | 0.058 | 0.078 | 19.4 | |
| | 11 | | 0.062 | 0.093 | 0.124 | 0.155 | 0.074 | 0.112 | 0.149 | 10.3 | |
| | 16 | | 0.137 | 0.206 | 0.275 | 0.343 | 0.165 | 0.247 | 0.330 | 4.8 | |
| | 22 | | 0.260 | 0.390 | 0.520 | 0.650 | 0.312 | 0.468 | 0.624 | 2.5 | |
| | 32 | | 0.550 | 0.825 | 1.10 | 1.37 | 0.660 | 0.990 | 1.32 | 1.2 | |
| | 44 | | 1.01 | 1.52 | 2.03 | 2.54 | 1.22 | 1.84 | 2.45 | 0.6 | |
| AXK- | 8 | 0-24 | 0.051 | 0.076 | 0.102 | 0.127 | 0.061 | 0.092 | 0.123 | 29.2 | 0.4/0.2 |
| | 11 | | 0.097 | 0.146 | 0.195 | 0.243 | 0.117 | 0.176 | 0.235 | 15.4 | |
| | 16 | | 0.215 | 0.323 | 0.431 | 0.538 | 0.259 | 0.389 | 0.519 | 7.3 | |
| | 22 | | 0.407 | 0.611 | 0.814 | 1.01 | 0.490 | 0.736 | 0.982 | 3.8 | |
| | 32 | | 0.861 | 1.29 | 1.72 | 2.15 | 1.03 | 1.55 | 2.07 | 1.8 | |
| | 44 | | 1.62 | 2.44 | 3.25 | 4.07 | 1.96 | 2.94 | 3.92 | 0.9 | |
| AXA- | 8 | 0-30 | 0.063 | 0.095 | 0.127 | 0.159 | 0.076 | 0.115 | 0.153 | 34.3 | 0.75/0.4 |
| | 11 | | 0.120 | 0.180 | 0.241 | 0.301 | 0.145 | 0.218 | 0.290 | 26.8 | |
| | 16 | | 0.260 | 0.391 | 0.521 | 0.652 | 0.314 | 0.471 | 0.628 | 12.6 | |
| | 22 | | 0.498 | 0.747 | 0.997 | 1.24 | 0.600 | 0.901 | 1.20 | 6.6 | |
| | 32 | | 1.07 | 1.61 | 2.15 | 2.69 | 1.29 | 1.94 | 2.59 | 3.1 | |
| | 44 | | 2.03 | 3.05 | 4.07 | 5.09 | 2.45 | 3.68 | 4.90 | 1.6 | |
| | 58 | | 3.53 | 5.30 | 7.07 | 8.84 | 4.26 | 6.40 | 8.53 | 0.9 | |
| | 68 | | 4.86 | 7.29 | 9.72 | 12.16 | 5.85 | 8.79 | 11.72 | 0.6 | |
| AXB- | 11 | 0-40 | 0.160 | 0.241 | 0.321 | 0.401 | 0.193 | 0.290 | 0.387 | 35 | 2.2/1.5/0.75 |
| | 16 | | 0.347 | 0.521 | 0.695 | 0.869 | 0.418 | 0.628 | 0.838 | 19.5 | |
| | 22 | | 0.664 | 0.996 | 1.32 | 1.66 | 0.800 | 1.20 | 1.60 | 15.0 | |
| | 32 | | 1.43 | 2.15 | 2.87 | 3.58 | 1.72 | 2.59 | 3.46 | 7.2 | |
| | 44 | | 2.71 | 4.07 | 5.43 | 6.78 | 3.27 | 4.91 | 6.54 | 3.7 | |
| | 58 | | 4.71 | 7.07 | 9.43 | 11.7 | 5.67 | 8.52 | 11.3 | 2.0 | |
| | 68 | | 6.48 | 9.72 | 12.9 | 16.2 | 7.80 | 11.7 | 15.6 | 1.6 | |
| | 88 | | 10.8 | 16.2 | 21.7 | 27.1 | 13.0 | 19.6 | 26.1 | 0.9 | |

Notes : The discharge is of clear water at room temperature under maximum discharge pressure.

For further details, please refer to the separate "Materials for IWAKI Metering Pump AX Series Selection."

■ Common Specifications

1. Materials of Liquid-Contacting Parts

| Pump Head Unit Name | PL | PH | PU |
|------------------------|-------------------|----|--------------|
| Pump head | SUS316 | | |
| Valve seat | SUS316 | | SUS316 + STL |
| Valve | SUS316 equivalent | | SUS440C |
| Valve guide | SUS316 | | |
| Valve gasket | PTFE | | |
| Sealing plate | SUS316 | | |
| Discharge port | SUS316 | | |
| Suction port | SUS316 | | |
| Plunger | SUS316 + HCr | | SUS316 + CE |
| Gland packing | * | | Carbon fiber |
| Gland packing spacer | PTFE | | SUS316 |
| Neck bush | - | | Carbon |

SUS316 : Stainless steel (18Cr-12Ni)

SUS440C : Stainless steel (18Cr-1.0C)

STL : Stellite

PTFE : Polytetrafluoroethylene

HCr : Hard chromium-coated

CE : Ceramic flame-coating

* : Teflon-impregnated aramid/inorganic fiber, teflon-impregnated teflon fiber or teflon-impregnated carbon fiber

2. Temperature range of liquid : -10 to 200°C
3. Ambient temperature : 0 to 40°C
4. Standard coating color : Ultra Marine Blue RAL5002 (excluding motor, which is in manufacturer's standard color)
5. Motor :
 - Standard : Flange type (IEC Standard)
 - Others : Various lateral types (common base directly connectable via couplings)

※ Please note that due to product improvement, sizes are subject to change without notice.

5. Description of Pump Mechanism & Points to Note During Operation

■ Description of Pump Mechanism

1. Gear reducer mechanism

The motor speed is reduced by a worm and a worm wheel. The standard reduction ratios are 1:30, 1:20, 1:15, and 1:12, (for 50Hz only).

2. SL crank mechanism

The SL crank mechanism is designed to adjust the stroke length. It comprises an eccentric disc, an SL crank and a coupling disc, all of which have the same eccentricity.

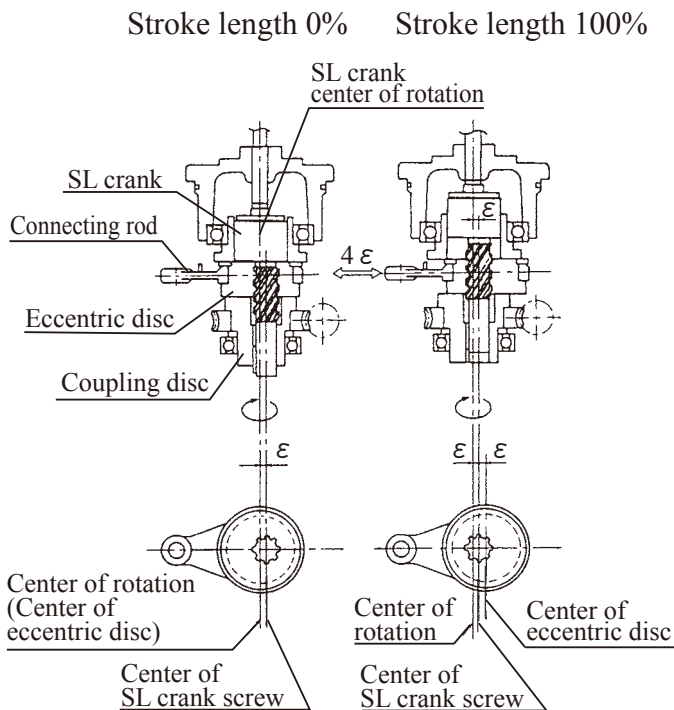

Principle of SL crank mechanism

- When stroke length is set at 100% (SL crank is pulled up)
When the SL crank is pulled up, the eccentric disc is rotated by means of the screw of the SL crank. At this point, the eccentric disc is shifted from the center of rotation of the SL crank to make the stroke length twice as long as the eccentricity. (In the diagram, the eccentric disc has rotated through 180 degrees to bring the eccentricity degree to 2ε .)
- When stroke length is set at 0% (SL crank is pushed down)
The center of the eccentric disc is aligned with the center of rotation of the SL crank. (The eccentricities ε of the SL crank and the eccentric disc are offset by each other to result in an eccentricity degree of 0.)

3. Stroke length control

To set, increase or decrease the discharge rate, the length of stroke is changed, which is carried out by rotating the control handle of the pump.

■ Notes on Operation

1. Shutoff operation prohibited

Never operate the pump without opening the valves in the piping on both the discharge and the suction sides. Do not throttle or close the valves in the discharge and suction piping while the pump is in operation.

2. Influence of change in temperature

Although the performance of the pump is not affected by a change in temperature, the liquid handled changes in viscosity, steam pressure, corrosion resistance, etc., as the temperature varies. Therefore, close attention should be paid to changes in the properties of the liquid handled likely to be caused by thermal variation.

▶ Temperature range of liquid handled by pump: -10 to 200°C

* For the recommended temperature ranges of chemical liquids, refer to the table of corrosion resistance data. If you have any further questions, please contact the dealer you placed your order with.

▶ Temperature range of atmosphere in which the pump is operated: 0 to 40°C

3. Effect of viscosity on performance

When an AX hydraulic diaphragm pump transfers a viscous liquid, the discharge tends to decrease slightly compared to clear water. In order to maintain precise metering, try to minimize a change in the viscosity through careful control of the temperature of the liquid. As the viscosity of the liquid rises, NPSHr increases. Accordingly, NPSHa should be set at a sufficiently high level if a viscous liquid is transferred.

4. Handling of slurry

Slurry should not generally be handled.

6. Installation, Piping and Wiring

■ Recommended Piping

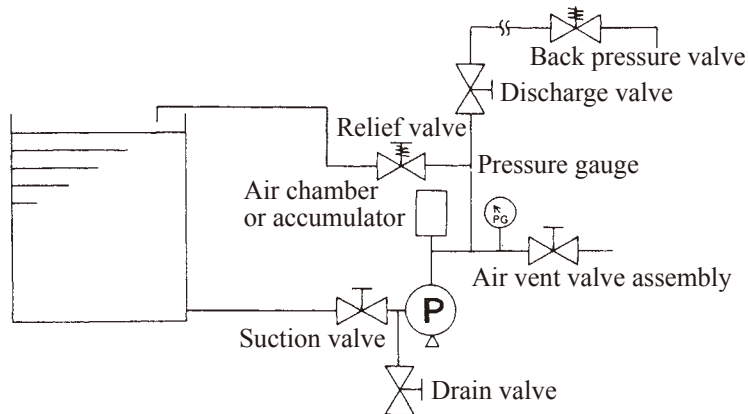

The piping system should be designed to fully meet the requirements for suction and discharge. Well-planned piping is a must particularly when a precipitable slurry is handled.

■ Installation Site

1. Position the pump as close to the suction side tank as possible, and lower than the lowest liquid surface of the tank. Choose the position that requires the shortest possible length of suction piping.
2. For ease of maintenance, have enough space around the installation. Take measures to prevent the danger of damage to the motor and power distribution equipment in disasters such as a flood.
3. The pump should be installed in a flat place, that is not subjected to the vibrations caused by other machines.

■ Foundation Work

1. As a concrete floor on soft ground tends to subside or incline, it is necessary to have a space wide enough to bear the weight of the pump and deep enough to prevent the pump from freezing in winter.
2. For the foundation bolts to be driven into the concrete floor, make holes as marked in the drawing or on the product. Level the floor surface as far as possible. Start installation only after the concrete has set fully.

■ Installation

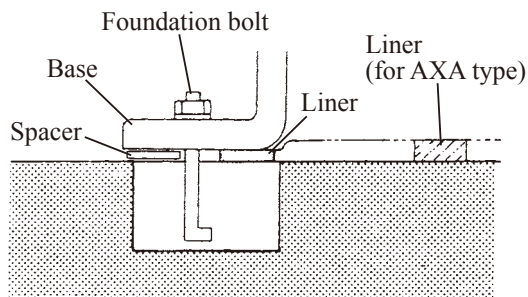

Liner: When the nut is tightened, remove the liner.

1. After the foundation work is complete, place the pump on the concrete foundation.
2. Insert the liner between the pump base and the concrete foundation surface to make a space for mortar grouting.
 - The liner should be inserted evenly (and horizontally) so as not to warp the foundation.
 - For the AXA type, the liner should be positioned under the non-machined part of the base.
3. Attach a nut at the head position of the screw of the foundation bolt and leave it hanging down in the hole for the foundation bolt hole in the base.
4. Grout mortar into the foundation bolt hole. Leave the mortar for a few days to harden.
 - The surface of grouted mortar should be at the same level as the foundation concrete surface. Use a level to see that the mortar surface is horizontal. If not, adjust it.
5. When the mortar has hardened, remove the liner from the base (or discharge port) of the pump to recheck the levelness. Next, fasten the nut of the foundation bolt. If it is not level, insert a spacer under the bottom of the base. Then, fasten the nut to fix the base.
6. Remove the plug of the driving unit, and mount the air breathers provided (ones with sealing tape wound round them). To mount an air breather, turn its upper hexagonal portion with a wrench.

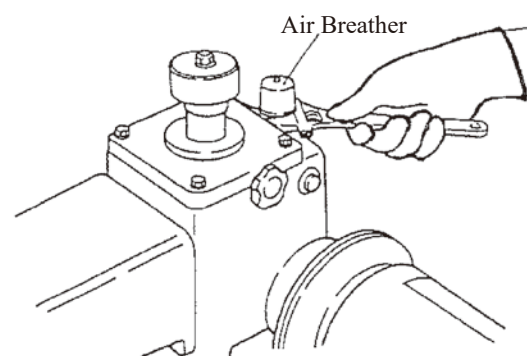
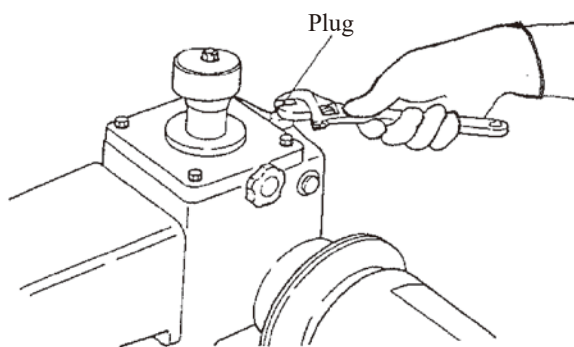

7. For the motor coupling type, centre the coupling parts.

The couplings connect the motor shaft to the drive unit shaft. After installation and plumbing are completed, the pump base can deform due to the weight of the piping on the pump, resulting in the misaligned couplings, abnormal noise, vibration and excessive wear on the motor bearings and drive unit bearings.

Ensure that the angular or parallel misalignment does not exceed:

- ▶ 0.1mm for the 0.2, 0.4 and 0.75kW motor.
- ▶ 0.2mm for the 1.5, 2.2, 3.7, 5.5 and 7.5kW motor.

If necessary, insert spacers on the deformed base to align the couplings within the above value.

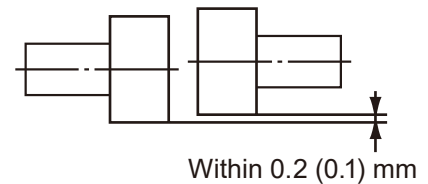

Every time the pump is disassembled and reassembled, check the alignment to ensure proper operation.

NOTE: Turn off the pump and electrical circuit breakers before performing the alignment.

■ Piping (General Matters to be Attended to)

1. The piping should be as short and with as few bends as possible. Care should be taken to prevent air traps.
2. Provide a support to prevent the piping from applying a load to the pump. Pay particular attention to this point when liquid contacting ends are PVC.
3. If the pump is used to transfer a high or low-temperature liquid, the piping should be designed to protect it from the influence of thermal expansion/contraction.
4. If a precipitable slurry is to be transferred, the piping should not have a U-shaped section. It is also necessary to provide a drain plug in the lowermost section of the piping.
5. If a viscous or toxic liquid, or a liquid likely to stick, is to be transferred, provide piping for flushing to facilitate maintenance and inspection.
6. When selecting the piping material, take into account corrosion resistance to the liquid to be handled and pressure to be applied to the piping.
7. Before installing the pipes, clean their insides thoroughly. To prevent foreign matter from entering, blind covers are provided at the inlet and outlet of the pump. Remove them before starting piping work.
8. If there is a risk of the liquid freezing in the piping, the piping has to be kept warm. To discharge the liquid remaining in the piping, the suction piping should be equipped with a drain cock.
9. If a PVC pipe is used in the discharge side piping of the pump, care should be taken not to let an adhesive flow into the pump.

■ Suction Piping

1. The press-in method must be used to install suction-side pipes. Use pipes which are larger in diameter than the pump inlet.
2. Care must be taken when attaching joints to suction piping, so as not to allow air to be sucked in. If air gets inside the suction piping, the discharge rate will become unstable.

■ Discharge Piping

1. For the protection of the pump, make sure to provide a relief valve in the discharge piping close to the pump. The discharge valve should be attached behind the relief valve.
2. The discharge piping must be able to withstand pressure higher than the relief valve setting. Take special care in fitting joints.
3. It is recommended to provide an air chamber or an accumulator as a means to suppress pulsation and to eliminate inertia resistance.
4. It is recommended to provide a back pressure valve so as to prevent overfeed as a result of insufficient pressure.
5. Install a pressure gauge for routine checks of discharge pressure.

■ Wiring

For wiring, use good quality materials and comply with the technical standard for electric installation and the indoor wiring regulations. Strict observance of the following is requested:

Example of Circuit Diagram

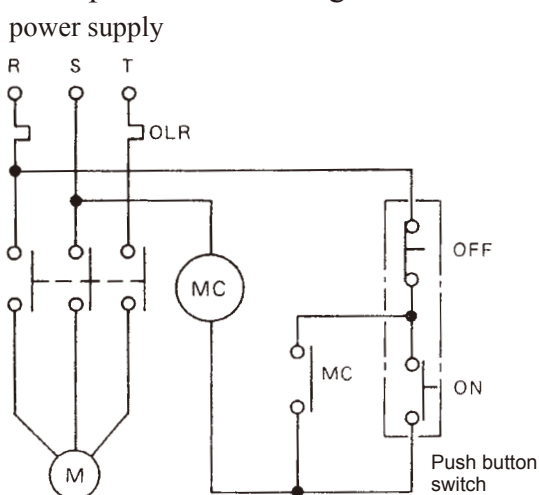

M motor
 MC electromagnetic switches
 ON } push button switches
 OFF }
 OLR Overload relay

1. Use an electromagnetic switch suitable for the specifications of the motor of the pump.
2. If the pump is used outdoors, wire it so as not to expose the switches to rainwater, etc.
3. The electromagnetic switch and push button switches must be installed securely, in a place away from the pump.
4. Wire so that the motor can rotate in the direction indicated by the arrow on the plate (clockwise when viewed from the fan cover side of the motor). When you confirm the direction, make sure to set the stroke at 0% before turning the power switch on.
5. An ampere meter must be installed to monitor the operation of the pump.

7. Operation

■ Stroke Adjustment

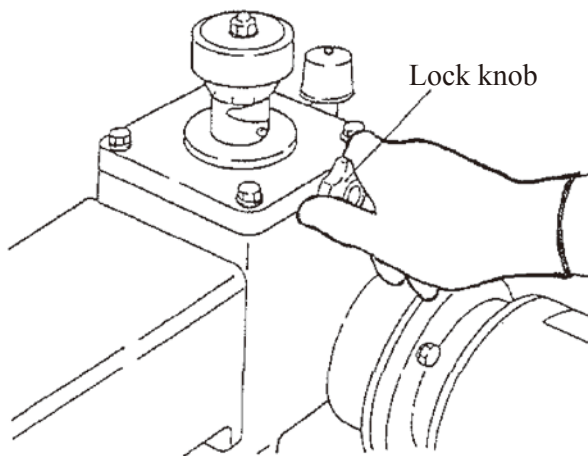
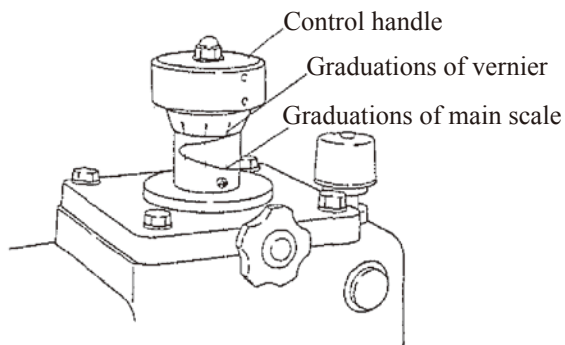

< Manual Operation >

A dial-type control handle is used to adjust the stroke. Adjustment is possible regardless of whether the pump is in or out of operation, but it is preferable to make it while the pump is in operation.

- ▶ Turning to the right (clockwise) decreases the stroke length to reduce the discharge.
- ▶ Turning to the left (counterclockwise) increases the stroke length to raise the discharge.

1. Select a suitable stroke from the standard performance curve of the pump or the table of test results. The graduations show strokes in %.
2. Loosen the lock knob. (The control handle is freed.)
3. Set the dial at the value of the intended stroke length. The total of the figure on the main scale and the one on the vernier represents stroke length (%).
4. After setting the stroke length, tighten the lock knob firmly. Then, try to move the control handle to confirm that it does not move.

< Electric servo or air servo operation >

Please refer to the electric servo/air servo instruction manual.

■ Preparation for Start-Up

During the initial run of the pump after its installation, the following points should be checked.

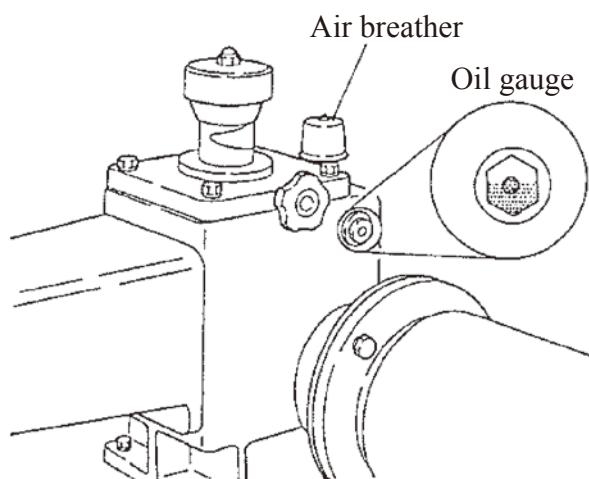

1. Is there any damage, loosened bolt, or oil leakage in the pump?
2. Has the plug of the driving unit been substituted with the provided air breather? See item 6 (page 12) of 'Installation'.
3. Confirm by means of the oil gauge in the driving unit that the driving and hydraulic units have the prescribed amounts of oil. (The red label in the middle position of the gauge indicates the prescribed amount.)
4. Make sure that the attachments needed for pump operation, liquid to be handled, and power supply are ready.

■ Operation

Following is the operation procedure of the pump when it is run for the first time after installation.

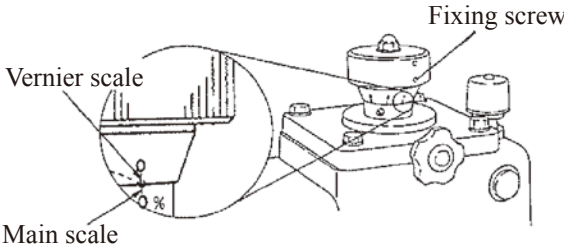
| | Procedure | Points to be Checked/Noted |
|---|---|---|
| 1 | ○ Fully open valves in discharge and suction piping. | |
| 2 | ○ Set stroke at 0%. | |
| 3 | ○ Turn on power switch of motor, to activate pump. | <ul style="list-style-type: none"> ● Confirm that motor rotates to right (clockwise) when viewed from fan cover side of motor. |
| 4 | ○ Make sure that the stroke length is 0%.  | <ul style="list-style-type: none"> ● Check whether the scale of the stroke length (where the zero points of the main and vernier scales meet) corresponds to the point at which the plunger movement is the smallest. ● If it does not correspond, loosen the screw (setscrew with hexagon socket on lower side) which secures the control dial, and fix it again at the point where the zero points of the vernier and main scales meet. |
| 5 | ○ Run pump with stroke at 0% for 10 minutes for break-in. During this period, confirm that everything is in order in all sections of pump. | <ul style="list-style-type: none"> ● In cold weather, overload (amperage above rating) may be observed for a while after start-up. This phenomenon is due to low temperature of oil in pump. If this happens, keep running pump in that no-load condition until oil temperature rises. |
| 6 | ○ Set stroke at 100% while avoiding pressurizing discharge side by making use of, for example, drain valve on discharge piping, and carry out break-in for approx. 10 mins. | |

| | Procedure | Points to be Checked/Noted |
|---|---|--|
| 7 | <ul style="list-style-type: none"> ○ If everything is found to be in order in break-in, close drain valve gradually and feed liquid to predetermined pipeline. | <ul style="list-style-type: none"> ● In this step, confirm that discharge pressure remains below max. pressure level, that amperage stays within rating, and that there is nothing out of order in all sections of pump. (Refer to the nameplates of pump and motor.) |
| 8 | <p>[Checking of discharge]</p> <ul style="list-style-type: none"> ○ If pump has no problem, check discharge under actual working conditions by using a gauge such as measuring cylinder. (Pump is in order if repeatedly measured discharges change little and linearity of discharges to strokes is maintained.) ○ For setting discharge, graph relation between discharges and strokes under actual working conditions. | <ul style="list-style-type: none"> ● If discharge is increased or decreased by changing stroke, wait for a minute or so before measuring it. ● If requested while placing order for pump, table of pump test results is supplied. Table shows results of tests on clear water at normal temperature (not on actual liquid or through actual piping). |

■ Notes on Operation

| | Precautions | Remarks |
|---|---|--|
| 1 | ○ Do not forget to open valves in piping both on suction and discharge sides before starting up pump. | |
| 2 | ○ Take care not to operate with motor rotating in reverse. | ● Confirm that motor rotates clockwise when viewed from fan cover side. |
| 3 | ○ Since operating pressure of relief valve is set according to specification of product ordered, please refrain from changing it. | |
| 4 | ○ In case air chamber is provided Air should be fed regularly to air chamber. For details, see instruction manual of air chamber. | <ul style="list-style-type: none"> ● Because liquid and air are directly in contact with each other in air chamber, a small amount of compressed air absorbs into the liquid. ● Thus, air keeps decreasing as time goes by, and it becomes difficult for the air chamber to fulfill its functions. To avoid this, air should be supplied at regular intervals. |

■ Stoppage of Operation and Restarting

1. When operation is resumed after a brief stoppage (within a week), the pump can be run with any length of stroke.
2. If the pump has been out of operation for a longer period (more than a week), the stroke should be set at 0% and about ten minutes' run in a no-load condition must be carried out. Do not start up the pump immediately for regular operation. Prior to that, an air vent run should be made with gradually increased stroke lengths after the inside of the driving unit is fully lubricated.
3. If the pump is put out of operation in cold weather (even briefly), open the drain piping on the suction side and run the pump without feeding liquid, to get rid of liquid from the piping and the pump chamber. This is to protect the pump from damage likely to be caused by frozen liquid. In case operation is interrupted temporarily and liquid cannot be drained, the pump should be kept warm by a band heater, etc., to prevent the liquid inside from freezing.

8. Maintenance and Inspection

■ Routine Operation

| No. | Checkpoint | Checking Method |
|-----|---|---|
| 1 | <ul style="list-style-type: none"> ● Is pump running smoothly? | <ul style="list-style-type: none"> ● By flow meter or visually ● Amperage of motor |
| 2 | <ul style="list-style-type: none"> ● Is there any change in discharge or discharge pressure? | <ul style="list-style-type: none"> ● By flow meter, pressure gauge or the like. ● Compare with figures on nameplate |
| 3 | <ul style="list-style-type: none"> ● Is there any leakage from liquid-contacting parts? | <ul style="list-style-type: none"> ● Examine sealed sections visually. |
| 4 | <ul style="list-style-type: none"> ● Does oil in gear reducer and hydraulic/driving units run short? ● Does oil leak from an oil seal, or is it soiled? | <ul style="list-style-type: none"> ● By oil gauge ● Visually Use a dry or damp cloth to wipe leaked oil off. Contact us for further assistance. |

■ Periodic Inspection

If there is a spare pump, run it from time to time. It should be serviced so as to be always ready for use.

| No. | Item | Remarks |
|-----|---|---|
| 1 | <ul style="list-style-type: none"> ● Inspection of discharge and suction valves ▶ Inspect them semiannually. | <ul style="list-style-type: none"> ● If unusual scratch or abrasion is found in any of them, replace it. ● For replacement, follow instructions (Page 25 and 26) in “Disassembly, Reassembly and Adjustment” section. |
| 2 | Oil change in driving unit <ul style="list-style-type: none"> ▶ ① Replacement period: at least once a year ▶ ② Quantity and brand of replacement oil ● Make sure to fill oil up to red label of oil gauge (middle position). | <ul style="list-style-type: none"> ● Oil in driving unit must be changed more than once a year. In first run which causes initial wear, replace oil when pump is operated for 500 hours. If emulsification or any other harmful phenomenon is observed, replace oil immediately. |

■ Quantity of Oil to be Changed (for reference)

| Model | Quantity of Oil (L) |
|-------|---------------------|
| AXJ | 0.9 |
| AXK | 1.5 |
| AXA | 2.4 |
| AXB | 7.0 |

■ Suitable Oil Brands (Reference)

| Company | Product Name |
|-----------------------------|-------------------|
| Shell Lubricants Japan K.K. | Shell Spirax EP80 |

■ Oil Change Procedure

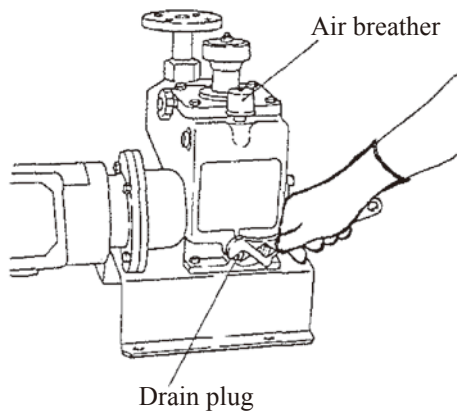

1. Stop the pump and release it from pressure, for example, by opening the drain valve in the piping.
2. Remove the drain plugs of the driving unit and let the oil out.
3. Clean the inside with new oil and flashing oil.
4. Wind sealing tape around the drain plugs and attach them to the bracket, cylinder head and driving unit.
5. Set the stroke at 0%.
6. Remove the air breather, and inject a suitable brand of oil up to the midposition of the oil gauge of the driving unit.

9. Troubleshooting Guide

| Cause | Problem | Motor does not move. | Discharge is insufficient or excessive. | Discharge is unstable. | Amperage of motor exceeds rating. | Liquid is not discharged. | Discharge pressure does not rise. | Liquid leaks. | Excessive vibrations and/or noise. | Oil leaks. | High temperature of driving unit | Remedy |
|--|---------|-----------------------|---|------------------------|-----------------------------------|---------------------------|-----------------------------------|-----------------------|------------------------------------|-----------------------|----------------------------------|---|
| Motor out of order | | <input type="radio"/> | | | <input type="radio"/> | | | | | | | Replace it. |
| Breaks or faulty connection | | <input type="radio"/> | | | <input type="radio"/> | | | | | | | Connect or replace wire. |
| Power fuse melted | | <input type="radio"/> | | | <input type="radio"/> | | | | | | | Find out cause and take suitable action. |
| Voltage lowered | | <input type="radio"/> | | | <input type="radio"/> | | | | | | | Find out cause and take suitable action. |
| Insufficient NPSH (cavitation) | | | <input type="radio"/> | <input type="radio"/> | | <input type="radio"/> | | | <input type="radio"/> | | | Review suction requirements. |
| Abrasion of valve seat | | | <input type="radio"/> | <input type="radio"/> | | <input type="radio"/> | <input type="radio"/> | | | | | Replace it. |
| Valve blocked with foreign matter | | | <input type="radio"/> | <input type="radio"/> | | <input type="radio"/> | | | | | | Disassemble and clean. |
| Suction piping and strainer blocked | | | <input type="radio"/> | <input type="radio"/> | | <input type="radio"/> | | | | | | Disassemble and clean. |
| Stroke setting dial out of place | | | <input type="radio"/> | <input type="radio"/> | | | | | | | | Readjust. |
| Liquid overfed due to insufficient differential pressure | | | <input type="radio"/> | <input type="radio"/> | | | | | | | | Increase the differential pressure. |
| Fluctuation in no. of strokes of pump | | | <input type="radio"/> | <input type="radio"/> | | | | | | | | Examine power source, motor and gear reducer. |
| Overload (excessive discharge pressure) | | | | | <input type="radio"/> | | | | | <input type="radio"/> | | Examine discharge piping system. |
| Improper specifications of power supply | | | | | <input type="radio"/> | | | | | | | Investigate. |
| Air sucked by suction side piping | | | <input type="radio"/> | <input type="radio"/> | | <input type="radio"/> | | | | | | Inspect piping and mend it. |
| Liquid handled changed | | | <input type="radio"/> | <input type="radio"/> | | <input type="radio"/> | | | <input type="radio"/> | | | Review pump specifications. |
| Pressure gauge defective | | | | | | | <input type="radio"/> | | | | | Replace it. |
| Mouth of pressure gauge clogged with dirt | | | | | | | <input type="radio"/> | | | | | Clean it. |
| Leak from safety valve | | | <input type="radio"/> | <input type="radio"/> | | <input type="radio"/> | | | | | | Readjust set pressure of safety valve. |
| Improper lubricating oil used for driving unit | | | | | <input type="radio"/> | | | | <input type="radio"/> | | <input type="radio"/> | Check amount, type and cleanliness of oil. |
| Oil seal/O ring out of order | | | | | | | | | | <input type="radio"/> | | Replace them. |
| Valve gasket out of order | | | <input type="radio"/> | | | <input type="radio"/> | | | | | | Replace it. |
| Damaged plunger/gland packing | | | <input type="radio"/> | | | | <input type="radio"/> | <input type="radio"/> | | | | Replace it. |
| The gland nut tightened with excessive force | | <input type="radio"/> | | | | <input type="radio"/> | | | | | <input type="radio"/> | Retighten the Gland nut. |

10. Disassembly, Reassembly and Assembly

While disassembling, reassembling or adjusting the pump, refer to the "Structure and Names of Parts" section. Since the driving unit was completely adjusted when it was assembled, do not disassemble it. If the need to disassemble it arises, please contact iwaki or your nearest distributor.

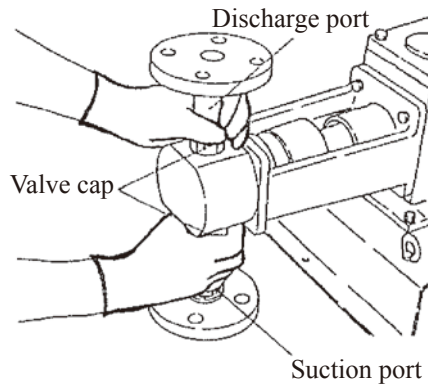

■ Disassembly and Reassembly of Valve Sets

< Disassembly >

1. Remove the pipes on the discharge and suction sides.
 - They should be removed after letting the liquid out of the pipes and the pump unit and closing the piping valves.
2. Remove the valve cap to detach the discharge and suction ports.
3. Take the valve sets out of the discharge and suction ports. If there is abnormal wear and tear in any part of the sets (valves, valve seats, etc.), replace it with a new one.

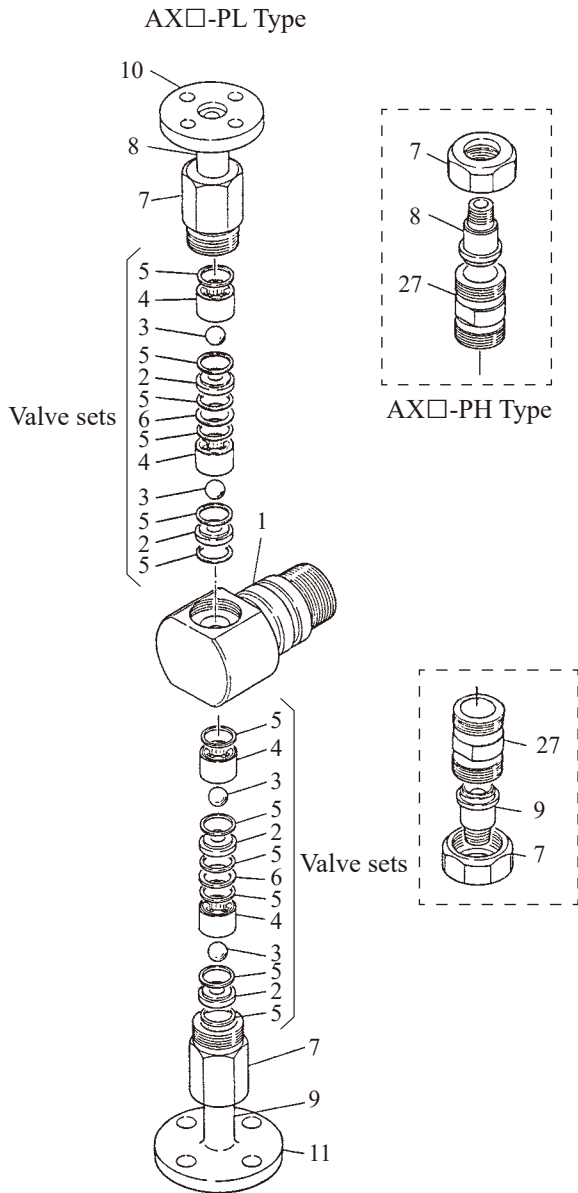

< Reassembly >

For reassembly, follow the steps of disassembly in reverse, paying attention to the following points.

- Erroneous assembly of set parts
If parts are assembled in the wrong order or direction, it will lead to unsatisfactory transfer of liquid (leakage).

Connection and insufficient tightening of parts

- The connections of pipes and parts should be securely tightened to prevent leakage.
- Adjust the flange surface (or discharge port) to make it horizontal, using a level.

Gland nut setting tool

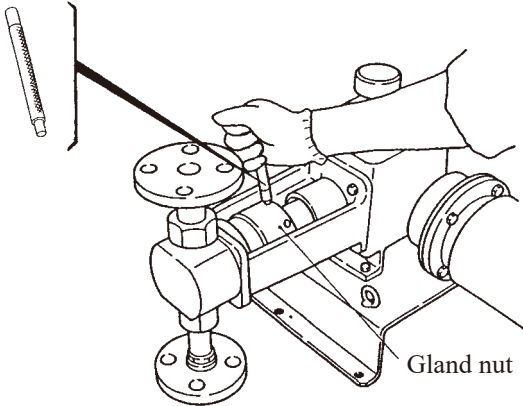

■ Replacement and Loading of Gland Packing

< Disassembly >

1. Remove the discharge and suction side pipes.
2. Loosen the gland nut by means of the provided setting tool.

● AX□-PL Type

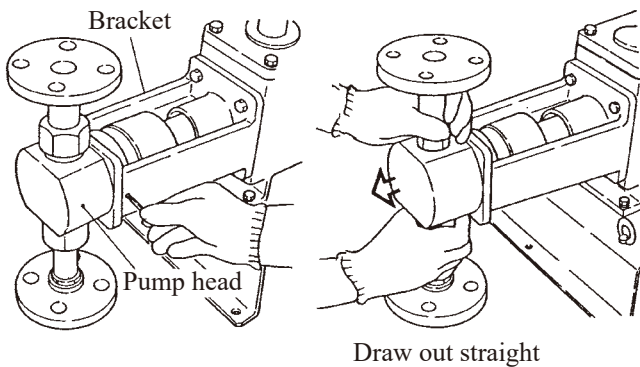

3. Detach the pump head.

① AX□-PL Type

In the PL type, loosen the four hexagon socket setscrews on the sides of the bracket and pull out the pump head.

● AX□-PH Type

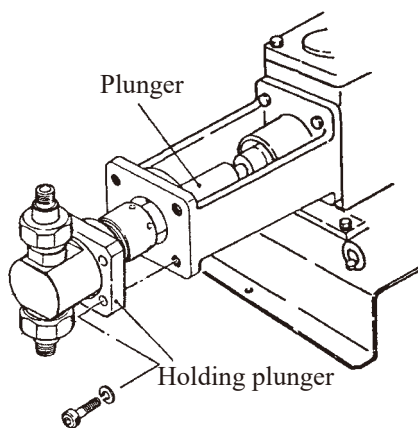

② AX□-PH Type

In the PH type, remove the four hexagon socket bolts in the holding flange in the front of the bracket, and take off the pump head.

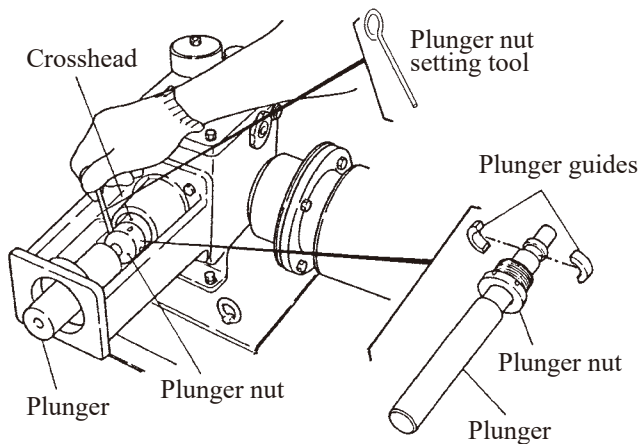

4. Loosen the plunger nut by means of the provided setting tool and slide them onto the plunger side. Then, draw out the plunger and the plunger guides.

- The plunger guides are fitted in the groove of the plunger. When you pull them out, care should be taken not to drop the plunger guides.

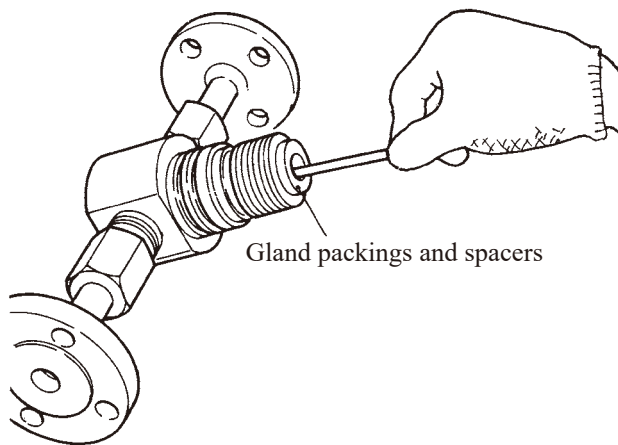

5. Take out the used gland packings and spacers. Take care not to damage the inside of the pump head.

6. When the pump head is empty, wash the inside of it. If an old packing is burnt inside, remove it with sandpaper, #400 or above.

Note: The spacers positioned in between gland packings are divided into two different material types. One is the Teflon spacer that is provided specially for the AX-PL type (5MPa or lower discharge pressure). The other is metal spacer specially for the AX-PH type (5-20MPa discharge pressure.). But then when the new gland packings are needed as spare parts for replacement, they will be always provided with Teflon spacers for both the AX-PL and AX-PH types. When using the AX-PH types, do not use the Teflon spacers. Reuse old metal spacers between the new gland packings.

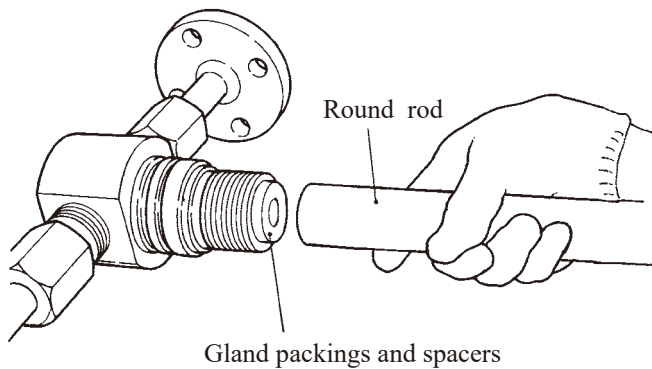
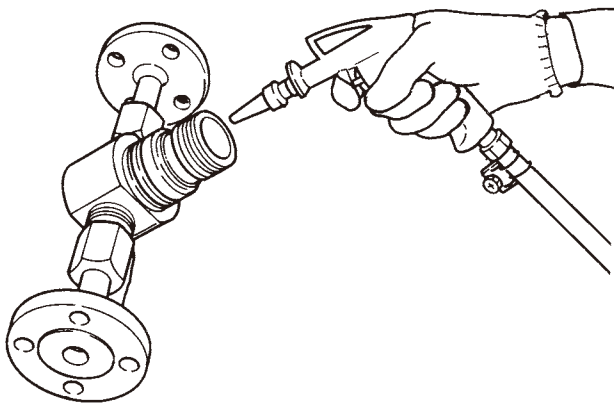

< Mounting >

7. Insert new gland packings and spacers. To do so, use a round rod of plastic or some other material, with a diameter slightly smaller than the outside diameter of the gland packings. Press in the spacers and gland packings alternately and ring by ring into the pump head, using the round rod. Stagger the cut sides of the packings by 90 degrees when inserting them.

- Do not insert packings forcibly with the end of a screwdriver, etc.

8. Insert the plunger into the pump head.

9. Mount the pump head onto the bracket.

10. Attach the plunger and plunger guides to the crosshead.

- First, insert the plunger in to the plunger nut and fit the plunger guides to the plunger. Then, mount them.

11. Fasten the gland nut in the following manner.

- ① To begin with, fasten the gland nut tightly by means of a Gland nut setting tool (so that the gland packings are stable in the pump head).
- ② Loosen the gland nut.
- ③ Tighten it fully by hand.

12. Reinstall the discharge and suction side pipes.

11. Normal Consumable Parts

When the pump is operated continuously for a long period of time, appropriate spare parts are needed. It is recommended that you always have expendable parts ready. When parts are ordered, we need the following information:

- ① the name of the product and product no. (as per the diagrams in this instruction manual)
- ② the model code and manufacturing no. of the pump (written on the nameplate)
- ③ if approved diagrams have been submitted to you, the diagram no.

■ AXJ, AXK, AXA and AXB Types

| No. | Name | Expected Life (Reference Value) | AX□-PL-PH (05, 08, 11, 16, 22, 32, 44) | AXA·AXB-PL (58, 68, 88) |
|-----|---------------|------------------------------------|---|----------------------------|
| | | | Quantity | Quantity |
| 2 | Valve seat | 1 year | 4 | 2 |
| 3 | Valve | | | |
| 4 | Valve guide | 2 years | | |
| 5 | Valve gasket | 1 year | 12 | 6 |
| 6 | Sealing plate | 2 years | 2 | |
| 36 | Plunger | 1 year | 1 | |
| 41 | Gland packing | 6 months | 1 set | |

● Number of Gland Packings Used (Including Spacers)

| Number Used Per Set | | Gland Packing | Spacer | | |
|---------------------|----|-------------------|--------------------|------------------|------------------|
| Model | | | | | |
| AX□-PL | 05 | 7 | 8 | | |
| | 08 | | | | |
| | 11 | | | | |
| | 16 | | | | |
| | 22 | | | | |
| | 32 | | | | |
| | 44 | | | J, K, A, 6, B, 7 | J, K, A, 7, B, 8 |
| | 58 | | | 6 | 7 |
| 68 | | | | | |
| 88 | 5 | 6 | | | |
| AX□-PH | 05 | 11 | 12 | | |
| | 08 | 10 | 11 | | |
| | 11 | | | | |
| | 16 | J, K, A, 9, B, 10 | J, K, A, 10, B, 11 | | |
| | 22 | J, K, A, 8, B, 9 | J, K, A, 9, B, 10 | | |
| | 32 | 8 | 9 | | |

*1 One or two gland packings or spacers would be needed depending on the material of the gland packing.

*2 Use the attached Teflon spacer for the AX-PL type.

*3 Use the metal spacer for the AX-PH type.

12. Parts Description and Exploded View

■ Pump Unit

The illustration shows completely disassembled condition to easily explain the construction, however, the pump must be disassembled to the extent which is instructed on the items "Maintenance and Inspection" and "Disassembly, Assembly and Adjustment" of this manual.

● AX□-PL Type

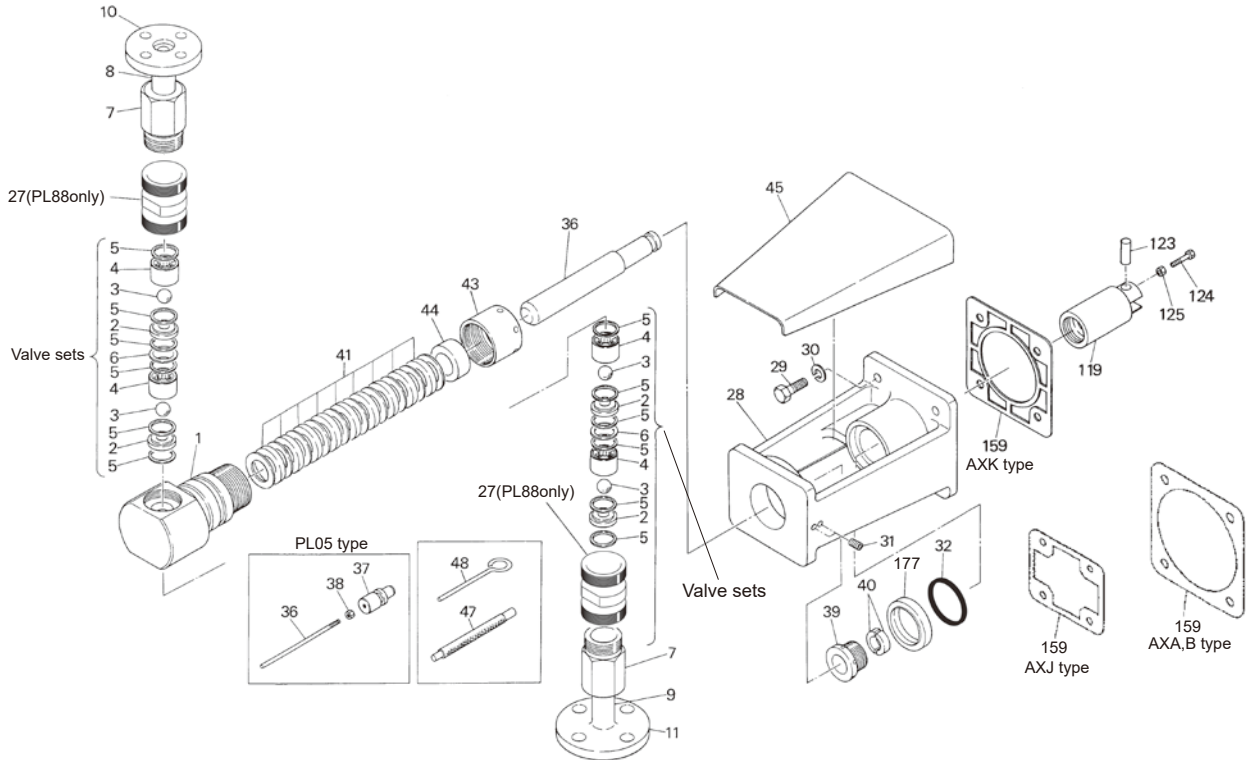

| No. | Name | Quantity | No. | Name | Quantity |
|-----|---------------------|----------|-----|--------------------------|----------|
| 1 | Pump head | 1 | 36 | Plunger | 1 |
| 2 | Valve seat | 4 *1 | 37 | Set plunger | 1 *1 |
| 3 | Valve | 4 *1 | 38 | Hexagon nut | 1 *1 |
| 4 | Valve guide | 4 *1 | 39 | Plunger nut | 1 |
| 5 | Valve gasket | 12 *1 | 40 | Plunger guide | 2 |
| 6 | Sealing plate | 2 *1 | 41 | Gland packing | 1 set |
| 7 | Valve cap | 2 | 43 | Gland nut | 1 |
| 8 | Discharge port | 1 | 44 | Gland ring | 1 |
| 9 | Suction port | 1 | 45 | Bracket cover | 1 |
| 10 | Flange | 1 | 47 | Gland nut setting tool | 1 |
| 11 | Flange | 1 | 48 | Plunger nut setting tool | 1 |
| 27 | Valve case *2 | 2 | 119 | Crosshead | 1 |
| 28 | Bracket | 1 | 123 | Crosshead pin | 1 |
| 29 | Hexagon bolt | 4 | 124 | Hexagon bolt | 1 |
| 30 | Spring washer | 4 | 125 | Hexagon nut | 1 |
| 31 | Hex socket setscrew | 4 | 159 | Case gasket | 1 |
| 32 | Packing | 1 | 177 | Case | 1 |

*1. The number changes depending on the model.

*2. Used with PL88 models only.

The illustration shows completely disassembled condition to easily explain the construction, however, the pump must be disassembled to the extent which is instructed on the items "Maintenance and Inspection" and "Disassembly, Assembly and Adjustment" of this manual.

● AX□-PH Type

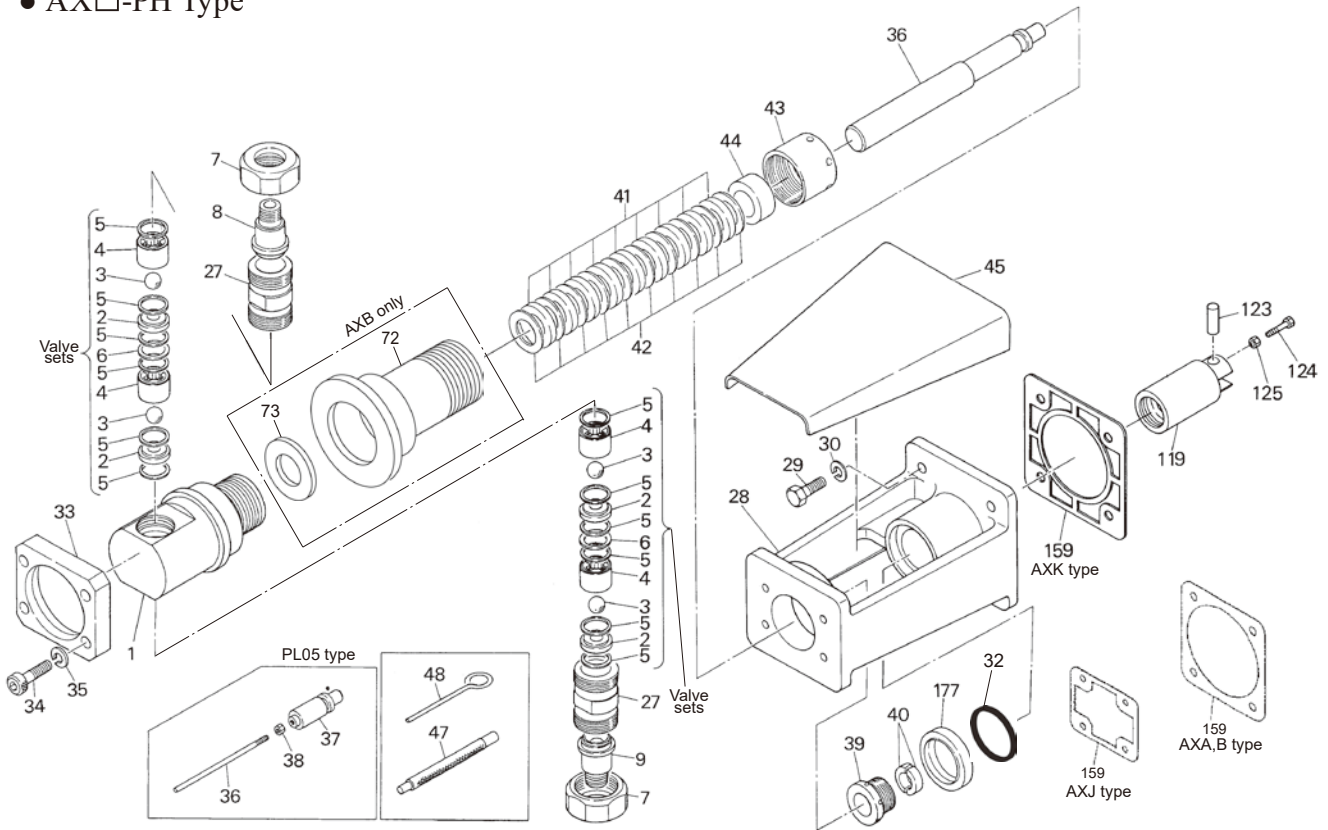

| No. | Name | Quantity | No. | Name | Quantity |
|-----|-----------------|----------|-----|--------------------------|----------|
| 1 | Pump head | 1 | 38 | Hexagon nut | 1 *1 |
| 2 | Valve seat | 4 | 39 | Plunger nut | 1 |
| 3 | Valve | 4 | 40 | Plunger guide | 2 |
| 4 | Valve guide | 4 | 41 | Gland packing | 1 set |
| 5 | Valve gasket | 12 | 42 | Gland packing spacer | 1 set |
| 6 | Sealing plate | 2 | 43 | Gland nut | 1 |
| 7 | Valve cap | 2 | 44 | Gland ring | 1 |
| 8 | Discharge port | 1 | 45 | Bracket cover | 1 |
| 9 | Suction port | 1 | 47 | Gland nut setting tool | 1 |
| 27 | Valve case | 2 | 48 | Plunger nut setting tool | 1 |
| 28 | Bracket | 1 | 72 | Head cylinder *2 | 1 |
| 29 | Hexagon bolt | 4 | 73 | Cylinder gasket *2 | 1 |
| 30 | Spring washer | 4 | 119 | Crosshead | 1 |
| 32 | Packing | 1 | 123 | Crosshead pin | 1 |
| 33 | Holding flange | 1 | 124 | Hexagon bolt | 1 |
| 34 | Hex socket bolt | 4 | 125 | Hexagon nut | 1 |
| 35 | Spring washer | 4 | 159 | Case gasket | 1 |
| 36 | Plunger | 1 | 177 | Case | 1 |
| 37 | Set plunger | 1 *1 | | | |

*1. The number changes depending on the model.

*2. Used with PL88 models only.



<https://www.iwakipumps.jp>

IWAKI CO.,LTD. 6-6 Kanda-Sudacho 2-chome Chiyoda-ku Tokyo 101-8558 Japan
TEL: +81 3 3254 2935 FAX: +81 3 3252 8892

European Headquarter / IWAKI Europe GmbH
TEL: +49 2154 9254 0 FAX: +49 2154 9254 48

Germany / IWAKI Europe GmbH
TEL: +49 2154 9254 50 FAX: +49 2154 9254 55

The Netherlands / IWAKI Europe GmbH (Netherlands Branch)
TEL: +31 74 2420011 FAX: +49 2154 9254 48

Italy / IWAKI Europe GmbH (Italy Branch)
TEL: +39 0445 561219 FAX: +39 0445 569088

Spain / IWAKI Europe GmbH (Spain Branch)
TEL/FAX: +34 934 741 638

Poland / IWAKI Europe GmbH (East Europe Branch)
TEL: +48 12 347 0755 FAX: +48 12 347 0900

Denmark / IWAKI Nordic A/S
TEL: +45 48 242345

Finland / IWAKI Suomi Oy
TEL: +358 10 201 0490

Norway / IWAKI Norge AS
TEL: +47 23 38 49 00

Sweden / IWAKI Sverige AB
TEL: +46 8 511 72900

Belgium / IWAKI Belgium N.V.
TEL: +32 13 670200 FAX: +32 13 672030

France / IWAKI France S.A.
TEL: +33 1 69 63 33 70 FAX: +33 1 64 49 92 73

U.S.A. / IWAKI America Inc.
TEL: +1 508 429 1440 FAX: +1 508 429 1386

Brazil / IWAKI Do Brasil Comercio De Bombas Hidraulicas LTDA.
TEL/FAX: +55 19 3244 5900

China (Shanghai) / IWAKI Pumps (Shanghai) Co., Ltd.
TEL: +86 21 6272 7502 FAX: +86 21 6272 6929

China (Hong Kong) / IWAKI Pumps Co., Ltd.
TEL: +852 2607 1168 FAX: +852 2607 1000

China (Guangzhou) / GFTZ IWAKI Engineering & Trading Co., Ltd.
TEL: +86 20 84350603 FAX: +86 20 84359181

China (Shenzhen) / IWAKI Pumps (Shenzhen) Co., Ltd.
TEL: +86 0755 8656 3696

Singapore / IWAKI Singapore Pte Ltd.
TEL: +65 6316 2028 FAX: +65 6316 3221

Indonesia / IWAKI Singapore (Indonesia Office)
TEL: +62 21 6906606 FAX: +62 21 6906612

Malaysia / IWAKIm SDN. BHD.
TEL: +60 3 7803 8807 FAX: +60 3 7803 4800

Korea / IWAKI Korea Co., Ltd.
TEL: +82 2 6238 4800 FAX: +82 2 6238 4801

Taiwan / IWAKI Pumps Taiwan Co., Ltd.
TEL: +886 2 8227 6900 FAX: +886 2 8227 6818

Thailand / IWAKI (Thailand) Co., Ltd.
TEL: +66 2 322 2471 FAX: +66 2 322 2477

Australia / IWAKI Pumps Australia Pty Ltd.
TEL: +61 2 9899 2411 FAX: +61 2 9899 2421