

IWAKI

Electromagnetic Metering Pump

EK Series

Instruction Manual

⚠ Read this manual before use of product

Thank you for selecting the electromagnetic metering pump EK series. This instruction manual deals with “Safety Section” “Product outline” “Installation Section” “Operation Section” and “Maintenance Section”.

Please read through this manual carefully to ensure the optimum performance, safety and service of the EK series.

Contents



IMPORTANT INSTRUCTION	1
Safety Instructions	2
<i>Outline</i>	5
1. Unpacking & Inspection	6
2. Operation Principle	6
3. Identification Codes	7
4. Features	8
5. Main Parts	8
6. Specifications	9
7. Operating Function	11
8. STOP Function	11
<i>Installation</i>	12
1. Before Use	13
2. Notes on Operation	13
3. Installation	14
4. Dimensions	15
5. Piping	18
6. Electrical Wiring	19
<i>Operation</i>	21
1. Bleeding	22
2. Flow rate Adjustment	24
3. Operation	25
4. Waterproof cover Mounting	29
<i>Maintenance</i>	30
1. Troubleshooting	31
2. Maintenance & Inspection	32
3. Wear Parts	33
4. Disassembly & Assembly	34
5. Exploded View	38
6. Accessories	42

This instruction manual should be kept on hand by the end user for quick reference. It is recommended that each user, after reading the instruction manual thoroughly, place it in a position close to the pump system and where it may be easily accessed by any user at any time whenever necessary.

Important Instructions

For the Safe and Correct Handling of the pump

- "Safety Instruction" section deals with important details about handling of the product. Before the use of the pump, read this section carefully for the prevention of personnel injury or loss.
- Observe the instructions accompanied with "WARNING" or "CAUTION" in this manual. These instructions are very important for protecting pump users from dangerous situations.
- The symbols on this instruction manual have the following meanings:

 WARNING	Nonobservance or misapplication of the contents of "Warning" section could lead to a serious accident which may result in death.
 CAUTION	Nonobservance or misapplication of the contents of "Caution" section could lead to a personal injury or damage to the product.

Types of Symbols



Indicates that "Warning" or "Caution" must be exercised. Inside this triangle, a concrete and practical image provided as a warning or caution message is depicted.



Indicates a prohibited action or procedure. Inside or near this circle, a concrete and practical image of the activity to be avoided is depicted.



Indicates an important action or procedure which must be performed or carried out without fail. Failure to follow the instructions herein can lead to malfunction or damage to the pump.

Safety instructions

WARNING

- **Turn off the power supply**

Working without disconnecting the power supply may cause an electrical shock. Before engaging upon any working procedures involving the pump, make sure to turn the power supply switch off and to stop the pump and other related devices.



- **Terminate operation**

When you detect or become aware of a dangerous sign or abnormal condition during operation, terminate the operation immediately and start it from the beginning again.



- **For specified application only**

The use of a pump in any application other than those clearly specified may result in injury or damage to the pump. Use the pump strictly in accordance with the pump specifications and application range.



- **No remodeling**

Never remodel a pump. Otherwise, a serious accident may result. Iwaki will not be responsible for any accident or damage of any kind which is caused by the user remodeling the pump without first obtaining permission or instructions from Iwaki.



- **Do not submerge**

The pump is not a submersible pump. Do not submerge the pump in the water or liquid.



- **Wear protectors**

If you touch or come in contact with any type of hazardous chemical liquid, including but not limited to chemicals, you may experience a serious injury. Wear protective gear (protective mask, gloves, etc.) during the pump operation.



CAUTION

- **Qualified operators only**

The pump operator and pump operation supervisor must not allow any operators who have little or no knowledge of the pump to run operate the pump. Pump operators must have a sound knowledge of the pump and its operation.



- **Specified power only**

Do not operate the pump on voltage which is not specified on the nameplate. Failure to do so may result in damage or fire. Only the specified power level is to be applied.



- **Do not run the pump dry**

Do not run the pump dry (without liquid inside the pump). Heat generated as a result of abrasion between elements inside the pump during operation without liquid may damage the inside of the pump.



Safety instructions

CAUTION

- **Ventilate**

Poisoning may result during an operation which involves toxic or odorous liquid. Ventilate the operating site sufficiently.



Caution

- **Damaged pump**

Never operate a damaged pump. A damaged pump may cause leakage or electrical shock.



Prohibited

- **Do not damage power cable**

Do not scratch, damage, process, or pull the power cable forcibly. An extra load onto the cable, such as heating the cable or placing something heavy on the cable, may damage the cable and finally cause a fire or an electrical shock.



Caution

- **Arrange grounding**

Do not operate the pump without connecting the grounding wire. Otherwise, an electrical shock may result. Make sure the grounding wire is connected with the grounding terminal.



Grounding

- **Install an earth leakage breaker (option)**

The operation of a pump without using an earth leakage breaker may cause an electrical shock. Please purchase an optional leakage breaker and install in the system.



Electrical Shock

- **Handling of power cable**

Use of a defective or damaged power cable may result in a fire or electrical shock. Handle the power cable carefully.



Electrical Shock

- **Follow the instruction manual**

Replace the consumable parts by following the descriptions in the instruction manual. Do not disassemble any part of the pump if the disassembling procedure for the part in question is not included in the instruction manual.



- **Limited operating site and storage**

Do not install or store the pump in the following places:

- * Places where a flammable gas or material is used or stored.
- * Places where the ambient temperature is extremely high (50°C or higher) or extremely low (0°C or lower).
- * Locations which receive direct sunlight.
- * Locations subject to high temperatures and high humidity.



Prohibited

- **Disposal of used pump**

Disposal of used or damaged pumps must be done in accordance with the relevant local laws and regulations. (Consult a licensed industrial waste products disposing company.)



Safety instructions

CAUTION

- **Waterproof cover mounting**

The waterproof property of IP67 is maintained as long as the waterproof cover is properly mounted. The waterproof cover has the direction for mounting. Do not mount it upside down. The cover must be fixed securely with six thumb bolts.

If the pump is used without the waterproof cover or with the cover wrongly mounted, the waterproof property of IP67 is not maintained resulting in pump failure. Water tightness is not maintained either when the six bolts are not tightened securely.



- **Frequent ON and OFF of pump must be done by STOP function (ON and OFF to STOP terminal). If you are forced to stop and start pump by turning on and off of power source, turning on and off must be limited to less than six times an hour.**

- **Do not make key operation with wet hand**

If the control panel gets wet and liquid enters the controller, the pump may malfunction. Wipe the control panel immediately if it gets wet.

Outline

<i>1.Unpacking & Inspection</i>	<i>6</i>
<i>2.Operation Principle</i>	<i>6</i>
<i>3.Identification Codes</i>	<i>7</i>
<i>4.Features.....</i>	<i>8</i>
<i>5.Main Parts</i>	<i>8</i>
<i>6.Specifications</i>	<i>9</i>
<i>7.Operating Function.....</i>	<i>11</i>
<i>8.STOP Function</i>	<i>11</i>

Outline

1. Unpacking & Inspection

Iwaki Metering Pump		Iwaki Logo	
MODEL		FREQUENCY	Hz
MAX.PRESS,	MPa	MFG.No.	
CAPACITY	ml/min	Year :	
STROKE RATE	spm	IWAKI CO.,LTD. TOKYO JAPAN	
VOLTAGE ~	V	IP67	CE
CURRENT	A	1P421783	

After unpacking the pump, check the following points to ascertain that the product is exactly as you ordered. If you find anything wrong, please get in touch with your dealer.

[1] Do the model, discharge pressure, voltage, etc., shown on the nameplate represent what you ordered?

[2] Has the pump been damaged in transit?
Are the bolts and nuts loose?

NOTE: The pump is not designed for submersible use. Do not submerge the pump in the water or liquid.

2. Operation Principle

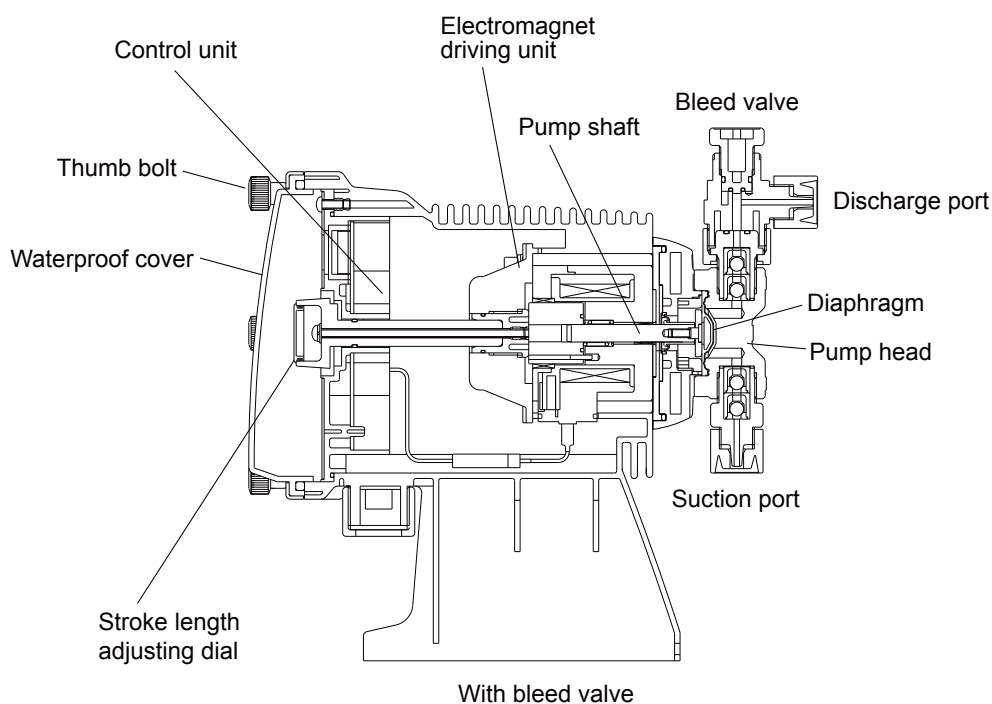

A pump shaft put in the electromagnet driving unit makes reciprocating movement which is brought by pulse current from controller. This reciprocating movement is transferred to the diaphragm which open and close by turns the discharge and suction valves to discharge the liquid. The speed of reciprocating movement (stroke rate per minute) can be changed by changing the pulse frequency of controller. The length of reciprocating movement (stroke length) can be adjusted by stroke length adjusting dial to adjust the discharge capacity per stroke. These two adjustments of stroke length and stroke speed enable fine adjustment of flow rate.

Outline

3. Identification Codes

(Example)

EK - B 11 PC - 20E P R 2 - □□
 (1) (2) (3) (4) (5) (6) (7) (8) (9)

(1) Pump Series

(2) Drive unit : B Average power consumption 20W
 C Average power consumption 22W

(3) Diaphragm diameter (Nominal mm)

11: 10mm, 16: 15mm, 21: 20mm, 31: 30mm, 36: 35mm

(4) Wet-end material

Parts	Diaphragm type					
	VC	VH	PC	PH	SH	TC
Pump head	PVC		GFRPP		SUS316	PVDF
Valve	CE	HC	CE	HC	HC	CE
Valve seat	FKM	EPDM	FKM	EPDM	SUS316	FKM
Valve gasket	PTFE		PTFE		PTFE	PTFE
O ring	FKM	EPDM	FKM	EPDM	–	FKM
Diaphragm	PTFE		PTFE		PTFE	PTFE

1. PTFE is coated on EPDM for the material of diaphragm.

2. Material symbol
 PVC : Transparent hard polyvinyl chloride
 GFRPP: Glass fiber reinforced polypropylene
 CE : Alumina ceramic
 HC : Hastelloy C 276
 EPDM : Ethylene propylene diene methylene
 FKM : Fluoroelastomer
 PTFE : Polytetrafluoroethylene
 PCTFE : Polychlorotetrafluoroethylene

(5) Power source

100 : AC100V/110V/115V 50/60Hz
 20E: AC220V/230V/240V 50/60Hz

(6) Power cord

Symbol	Cord end
No symbol	Press-fit terminal
P	With plug

(7) Controller type R : R type

(8) Connection hose

Symbol	Hose diameter (mm)
1	4 × 9
2	4 × 6
3	6 × 8
4	8 × 13
5	9 × 12
6	10 × 12
9	Rc1/4" (Female)

(9) Special version code

Outline

4. Features

- 1) EK Series pump is a totally enclosed and water-proof construction (IP67 certified) type electromagnetic metering pump. The waterproof property of IP67 is maintained as long as the waterproof cover is properly mounted.
- 2) The pump is water-proof construction and can be installed outdoor. Electronics parts and print circuit board are moulded by plastic resin to avoid the deterioration by humidity.
- 3) Many kinds of control can be done easily because of CPU built-in controller. Touch key operation enables easy setting of stroke rate.
Automatic control by external pulse signal.
Pump can be stopped by external contact signal.
- 4) The waterproof cover prevents liquid from entering the controller.

5. Main Parts

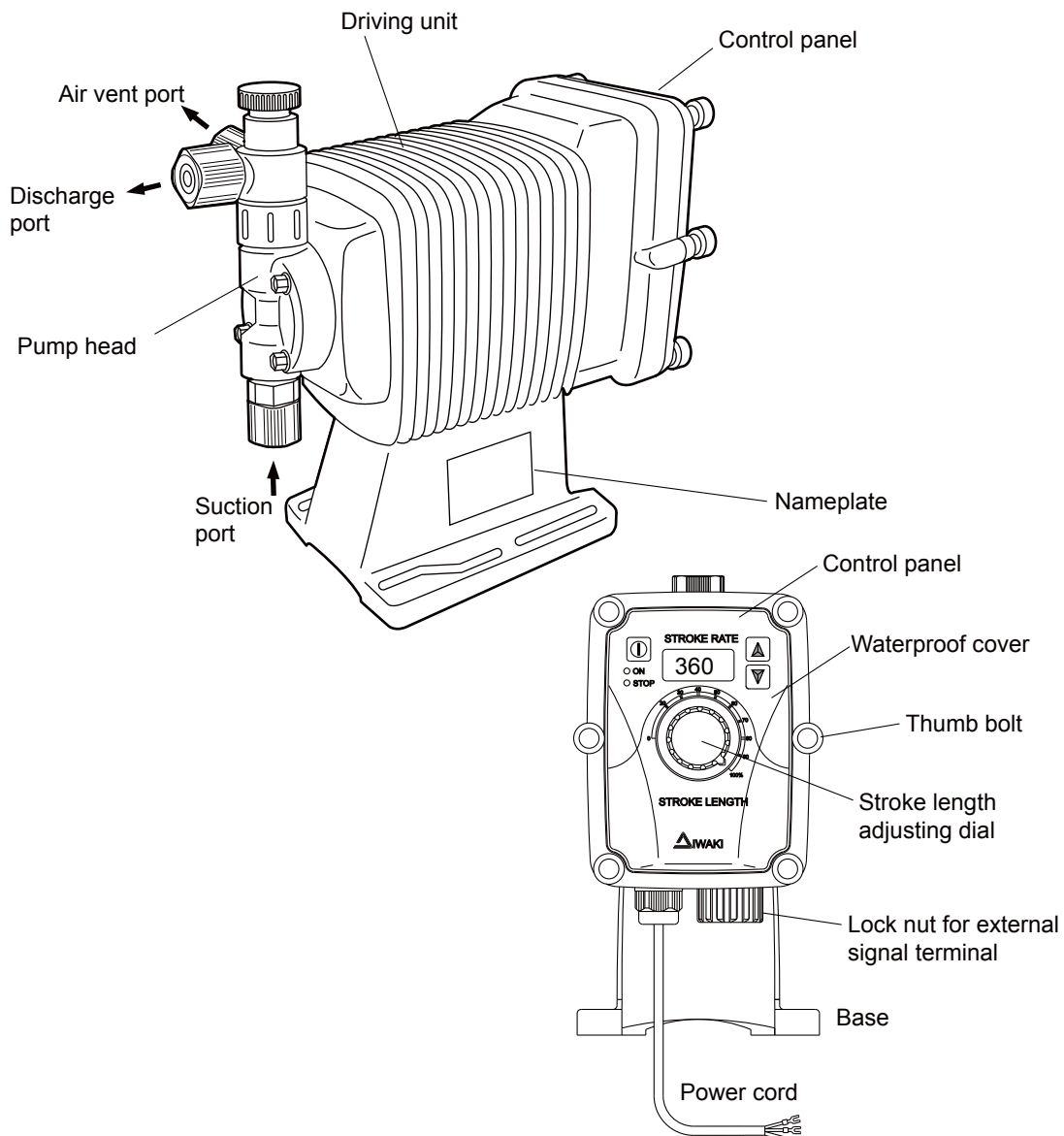

Outline

6. Specifications

■ Wet-end material codes : VC, VH, PC, PH

Model		B11	B16	B21	B31	C16	C21	C31	C36
Max. disch. capacity	mL/min	40	65	115	210	80	145	270	420
	L/hr	2.4	3.9	6.9	12.6	4.8	8.7	16.2	25.2
Disch. capacity per shot	mL/shot	0.11	0.18	0.31	0.58	0.22	0.40	0.75	1.17
Max. disch. pressure	MPa	1.0	0.7	0.4	0.2	1.0	0.7	0.35	0.2
Stroke length	mm	1.0 (Effective adjusting range : 40-100%)				1.25 (Effective adjusting range : 30-100%)			
Stroke rate	spm	1-360							
Power source		Refer to item 3. "Identification Codes" on page 7.							
Insulation, etc.		Insulation class E, With thermal overload protector, With 2.0m long power cord							
Average input power	W	20				22			
Connection (hose dia.)	mm	4 × 6, 4 × 9, 6 × 8			8 × 13, 9 × 12		4 × 6, 4 × 9, 6 × 8		8 × 13, 9 × 12
Mass	kg	2.8				3.7			

■ Wet-end material code : SH

Model		B11	B21	C21	C31	C36
Max. disch. capacity	mL/min	40	115	135	270	400
	L/hr	2.4	6.9	8.1	16.2	24.0
Disch. capacity per shot	mL/shot	0.11	0.31	0.38	0.75	1.11
Max. disch. pressure	MPa	1.0	0.4	0.7	0.35	0.2
Stroke length	mm	1.0 (Effective adjusting range : 40-100%)		1.25 (Effective adjusting range : 30-100%)		
Stroke rate	spm	1-360				
Power source		Refer to item 3. "Identification Codes" on page 7.				
Insulation, etc.		Insulation class E, With thermal overload protector, With 2.0m long power cord				
Average input power	W	20		22		
Connection		Rc1/4 female threads				
Mass	kg	3.9		4.7	5.5	5.8

Outline

■ **Wet-end material code : TC**

Model		B11	B21	C21	C31	C36
Max. disch. capacity	mL/min	40	115	135	270	400
	L/hr	2.4	6.9	8.1	16.2	24.0
Disch. capacity per shot	mL/shot	0.11	0.31	0.38	0.75	1.11
Max. disch. pressure	MPa	1.0	0.4	0.7	0.35	0.2
Stroke length	mm	1.0 (Effective adjusting range : 40-100%)		1.25 (Effective adjusting range : 30-100%)		
Stroke rate	spm	1-360				
Power source		Refer to item 3. "Identification Codes" on page 7.				
Insulation, etc.		Insulation class E, With thermal overload protector, With 2.0m long power cord				
Average input power	W	20		22		
Connection (hose dia.)	mm	4 × 6			10 × 12	
Mass	kg	3.1		3.9	4.0	

NOTE 1. Max. discharge capacity and discharge capacity per shot are based on pumping clear water at ambient temperature.

2. Max. discharge capacity is the value at max. discharge pressure and stroke rate. Discharge capacity increases when the discharge pressure is low.
3. Handled liquid temperature : 0 – 60 deg. C (0 – 40 deg. C for wet-end material codes VC, VH)
4. Ambient temperature : 0 – 50 deg. C (0 – 45 deg. C for wet-end material codes VC, VH)
5. Ambient humidity : 35 – 95% RH (No dew drop should be inside the pump)
6. Temperature to be stored : -10 – 50 deg. C

Installation

<i>1. Before Use.....</i>	<i>13</i>
<i>2. Notes on Operation.....</i>	<i>13</i>
<i>3. Installation.....</i>	<i>14</i>
<i>4. Dimensions.....</i>	<i>15</i>
<i>5. Piping.....</i>	<i>18</i>
<i>6. Electrical Wiring.....</i>	<i>19</i>

Installation

1. Before Use

"Strictly observe the following points."

Read through this instruction manual before installation. Do not run the pump with a poor understanding.

EK Series is an enclosed and water-proof construction, however use the pump observing the following conditions.

- 1) Do not submerge the pump. This pump is not a submersible pump.
- 2) Do not splash a chemical liquid. Otherwise, Pump body or wires/cords may be corroded.
- 3) It is not recommended the pump is installed at the place where it is exposed to sunlight.
- 4) Be sure to mount the waterproof cover. Note that the waterproof cover has a mounting direction. Tighten six thumb bolts securely.

WARNING

- **Turn off power**

Working with power ON may cause an electrical shock. Before working on the pump, make sure turn off main power.

- **Terminate operation**

On detecting or becoming aware of any abnormal condition, stop the operation immediately and remove problems.

- **Specified power only**

Be sure to connect earth wire. Do not apply any power other than specified one on nameplate.

- **Keep the pump away from heat or flame**

Do not place any dangerous materials or flammable objects near the pump for safety.

- **Damaged pump**

Never use any damaged pump. Use of a damaged pump may result in leakage or electrical shock.

2. Notes on Operation

- Dropping the pump or subjecting it to strong impacts may result in faulty performance. Handle the pump with care.

- Select an installation site convenient for future maintenance & inspection. Always fix the pump on a flat floor free of vibrations.

- **Maintain ventilation**

Poisoning may result when toxic/odorous liquid is used. Ventilate the operating site sufficiently.

- **Do not wet the pump**

If an electric part or wiring gets wet with the liquid spilled over accidentally, a fire or electrical shock may be caused. Install the system in a place free from liquid spillage or leakage.

- **Install an earth leakage breaker**

Pump operation without an earth leakage breaker may lead to an electrical shock. Purchase an optional leakage breaker and install it in the system.

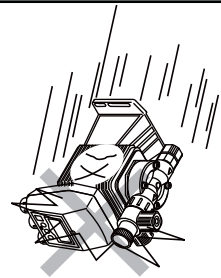

Prohibited

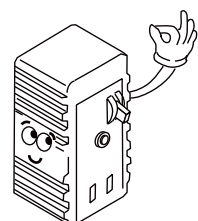

Installation

3. Installation

1) Ambient conditions

Temperature : 0 – 50 deg. C (0 – 45 deg. C for PVC type)

Humidity : 35 – 95% RH (No dew drop should be inside the pump.)

Storage temperature : -10 – 50 deg. C

2) Install the pump at horizontal place where no vibration is generated.

3) Keep the space for maintenance works around the pump.

4) Install the pump as close to the supply tank as possible. It is recommended that the pump is installed below the liquid level of the tank.

5) Suction side piping should be as short as possible. (Less than 2 m)

6) When handling chemicals which generate bubbles such as sodium hypochlorite or hydrazine, install the pump and tank at cool and dark place. Otherwise, the pump may be air-locked due to the bubbles.

Installation

4. Dimensions

EK-B11, B16, B21, C16 and C21 Types (VC, VH, PC, PH, TC)

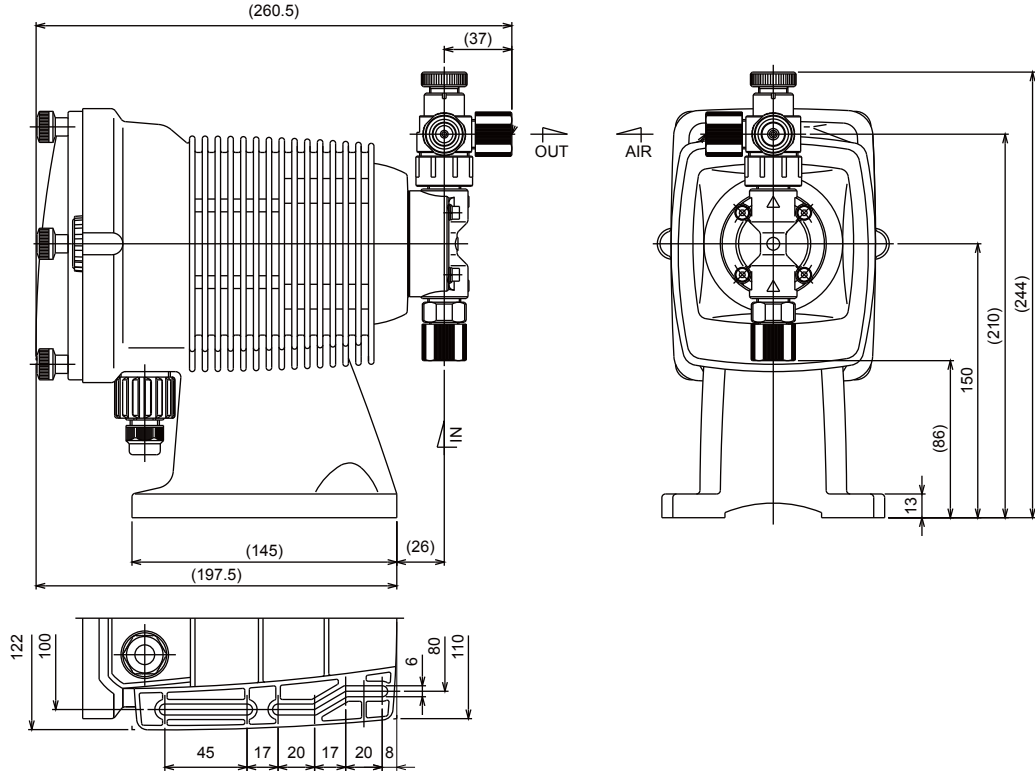

EK-B31 and C31 Types-(VC, VH, PC, PH, TC)

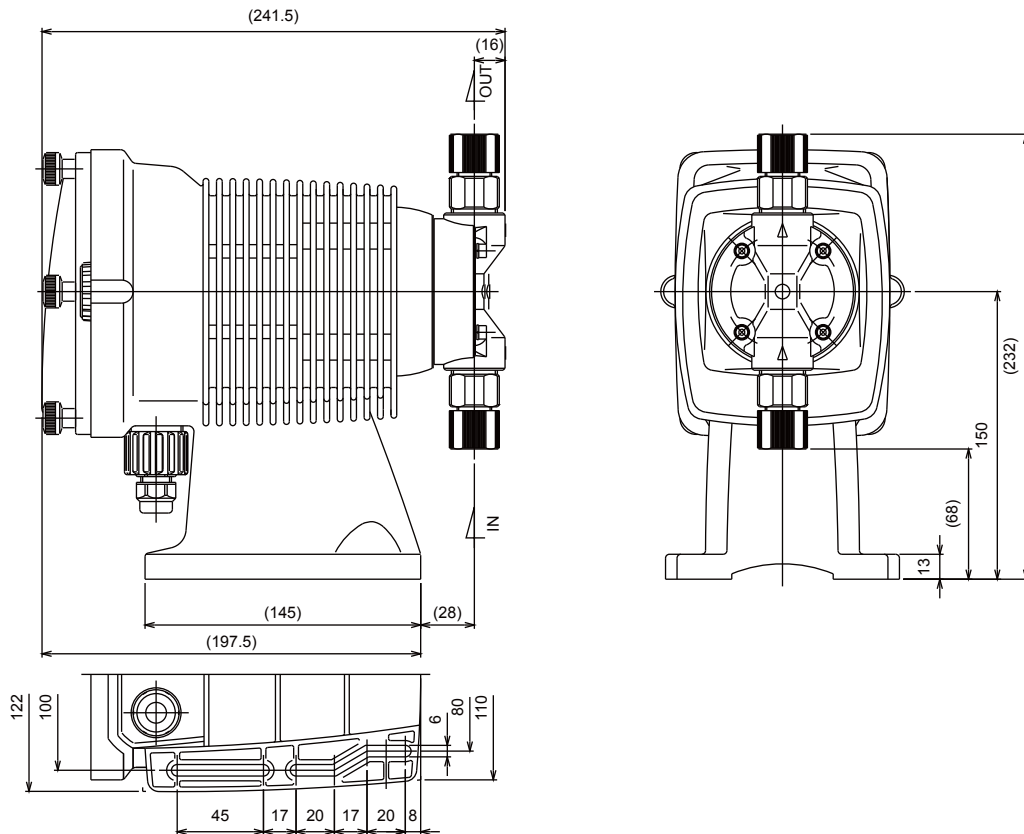

Installation

EK-C36 (VC, VH, PC, PH, TC)

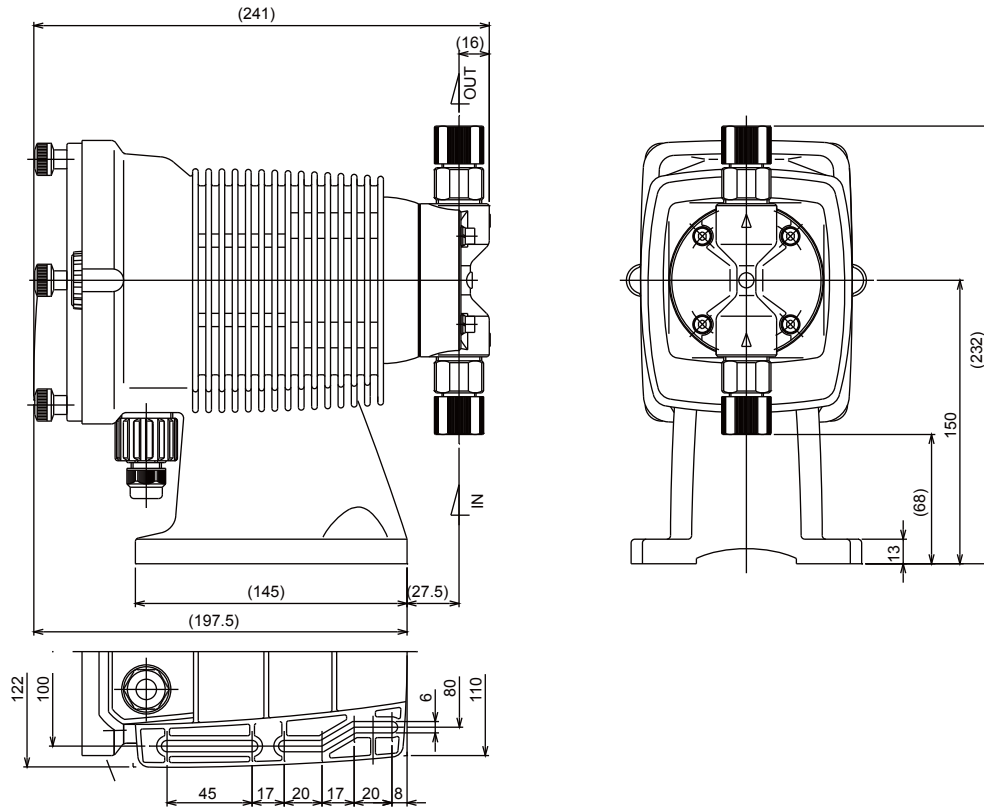

EK-B11, B21, C21 Types (SH)

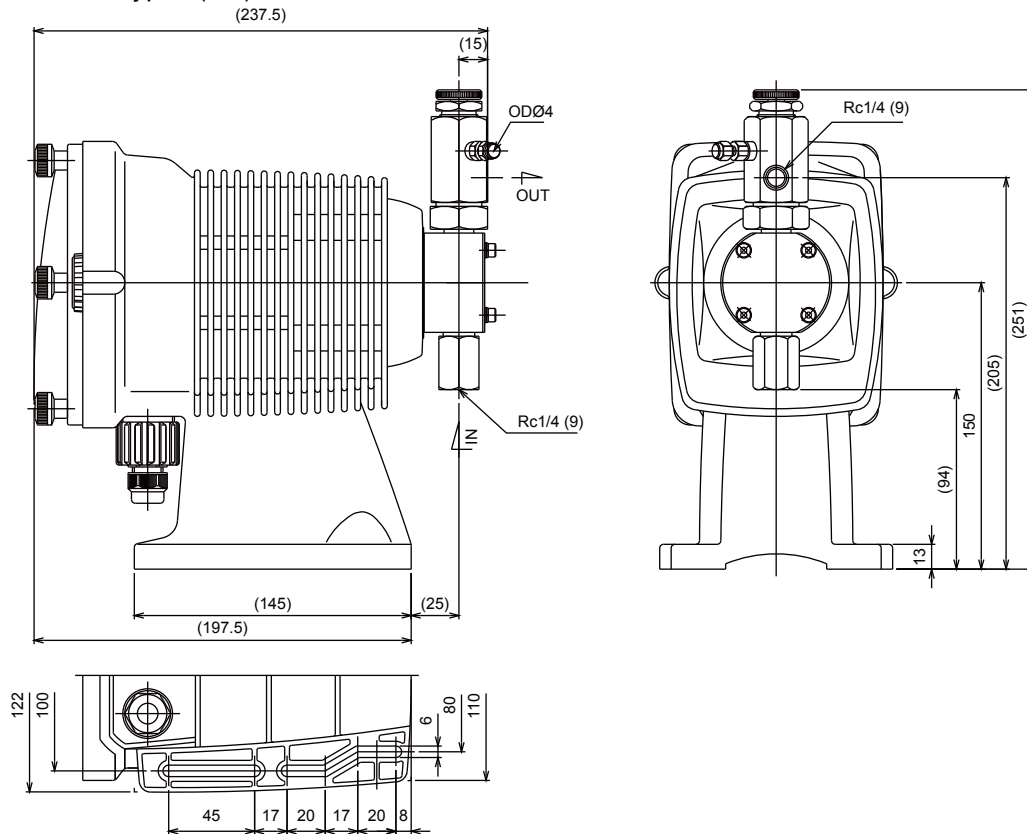

Installation

EK-C31 Type (SH)

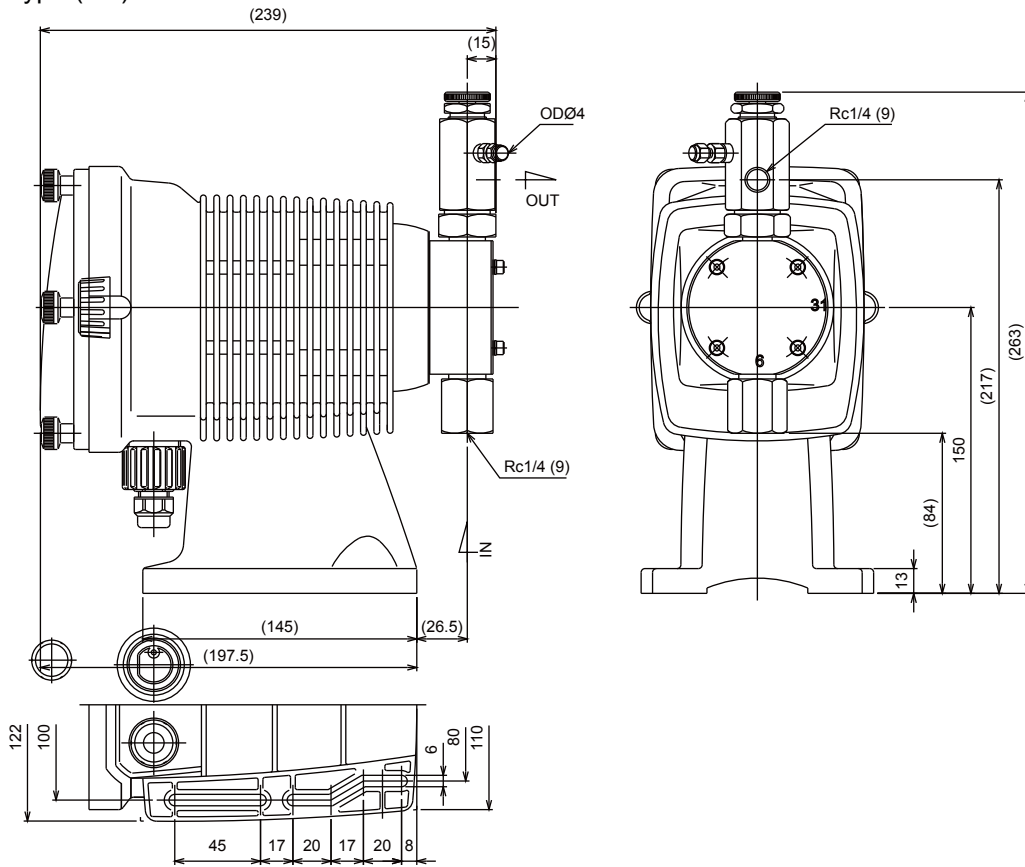

EK-C36 Type (SH)

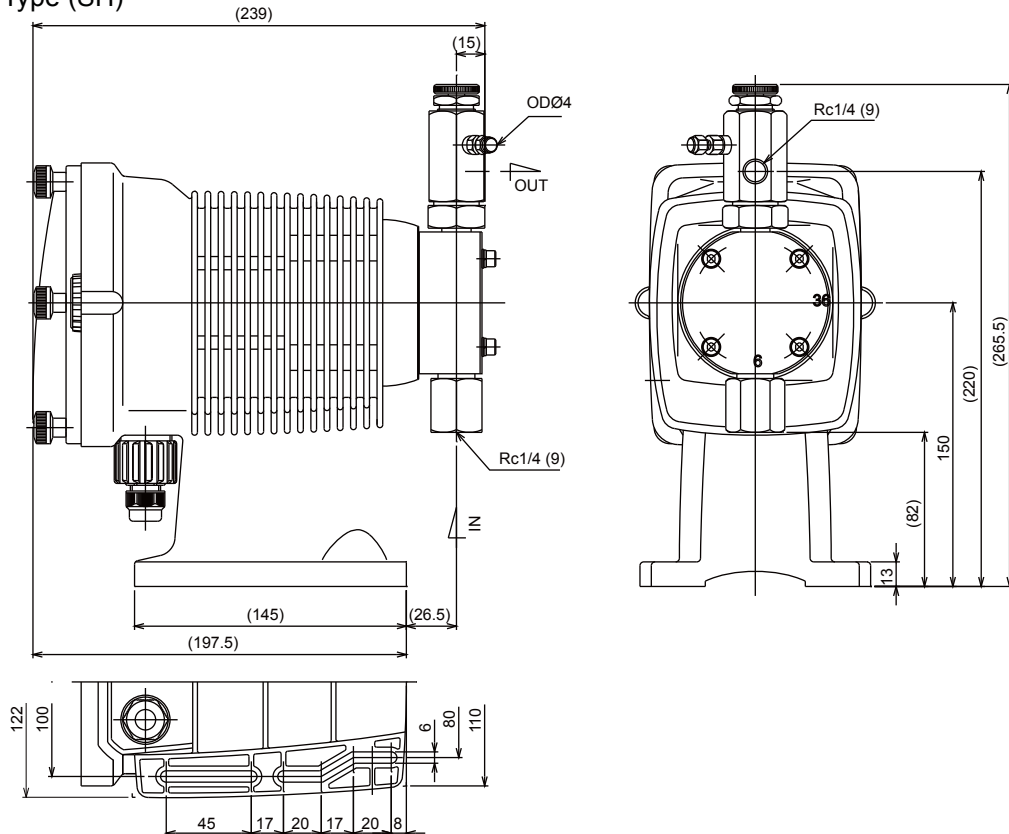

Installation

5. Piping

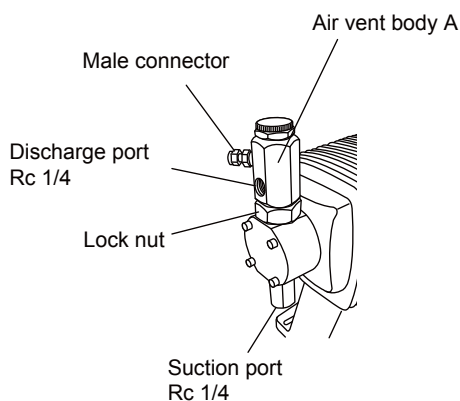
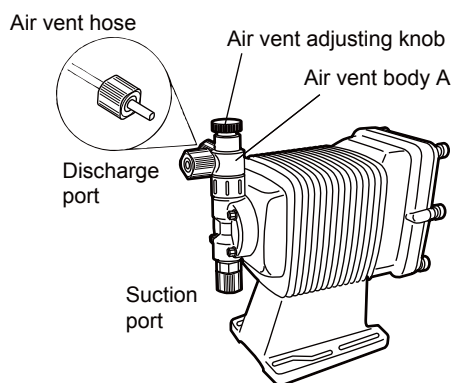
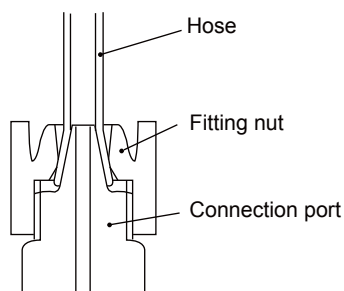

■ Connection of hose for material codes VC, VH, PC, PH, TC

- 1) After the hose is put on the connection port and the fitting nut is tightened by hand, tighten the nut by half turns by wrench. Securely tighten the nut so that the liquid can not leak nor suck the air.

⚠ CAUTION

Since the fitting nut and connection port are made of plastic resin, do not fasten the nut too tightly. Otherwise, they may be broken.

- 2) Connect a hose to the air vent port. Return another hose end to the tank.
- 3) Adjust the direction of air vent port. It can be directed freely.
 - a. Loosen by wrench a lock nut below the air vent body A turning it to left.
 - b. Position the direction of air vent port.
 - c. Tighten the lock nut holding by hand the air vent body A.
 - d. Tighten further the lock nut by wrench by 1/4 turns.

⚠ CAUTION

Diaphragm type of EK-31 and 36 are not equipped with the air vent valve.

■ Connection of hose for material code SH

- 1) Connection port is Rc1/4 female threads. Use proper size of pipe and securely connect pipe so that liquid can not leak or air can not be sucked in.
- 2) Screw the attached male connector in the bleed port.
- 3) Connect hose of 4 mm dia. to the male connector. Return the hose end to the tank.
- 4) Adjust the direction of discharge port to any desired direction.
 - a. Turn the lock nut to counter clockwise with wrench to loosen it.
 - b. Adjust the direction of discharge port.
 - c. Holding the air vent body A by hand, turn the lock nut to clockwise to tighten it.
 - d. Turn the lock nut to clockwise by one fourth turn with wrench to retighten it.

■ Check valve

Check valve is to be mounted in the discharge piping to avoid siphon phenomenon and over-feeding. Do not fail to install the check valve in case :

- 1) Discharge end is lower than liquid level of tank. (To avoid siphon phenomenon.)
- 2) Too low discharge pressure (To avoid over-feeding)
In case the discharge pressure is lower than 0.13 MPa for EK-B11/B16/B21/C16/C21/C31 and 0.049 MPa for EK-B31/C36.

Check valve must be installed at the end of discharge hose and at a distance of 1 meter or more apart from the pump.

Installation

6. Electrical Wiring

⚠ CAUTION

- Only qualified operators/service staff should be in charge of the related electrical arrangement and control of the power source. Failure to observe this instruction may result in injury to person or damage to assets.
- Never do the wiring when the power is switched on and the pump is operating to avoid electrical shock to the person and pump damage.

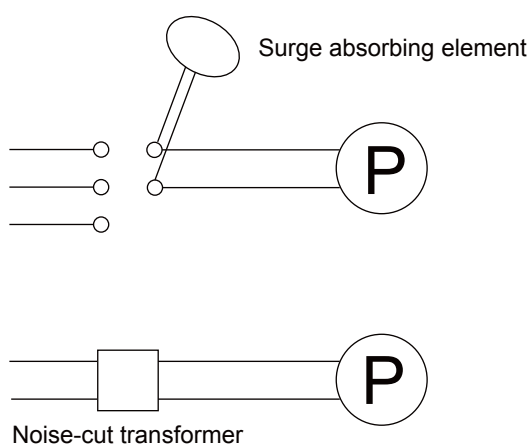

- Surge voltage
The electronic circuit of the control unit may be affected by excessively high surge voltage. So, do not operate the pump near high-power electrical equipment that generates high surge voltage. Take either of the following measures under unavoidable circumstances.
 - (1) Use a surge absorbing element (such as a varistor with surge resistance of 2000A or more) at the pump power supply connection.
 - (2) Use a noise-cut transformer.

Connection of external signal cord

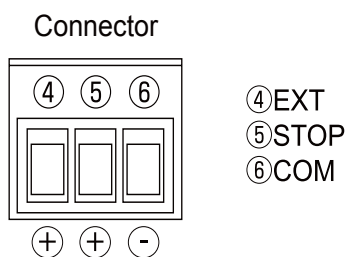
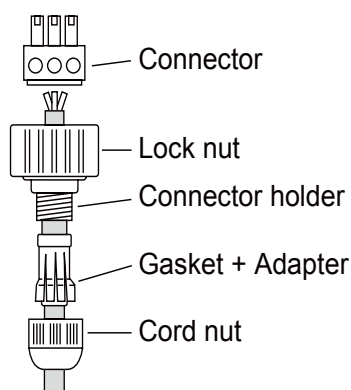

- 1) Remove a lock nut from the port for the external signal cord located at the bottom of the pump.
- 2) Insert the external signal cord through the lock nut which was removed from the pump, cord nut, adapter + gasket, connector holder which are separately attached to the pump. Connect the wires to the connector as shown on the figure at left. Use the cord of diameter $\varnothing 4.6 - 7.6$. If other size of cord is used, the cord can not be connected or the perfect sealing can not be done.
- 3) Put the connector to the connector holder, and tighten the cord nut.
The connector and the connector holder have the direction. Put them together mating the marks.
- 4) Direct the cutout side of the connector holder to the controller panel side, and insert the connector into the mated connector which is located in the pump inside. Tighten the lock nut securely. Loose tightening causes wrong sealing.

⚠ CAUTION

Wiring of EXT and STOP
Do not combine EXT and STOP wires with power cord. Do not combine pump power cable with EXT, STOP wires putting into coaxial cable such as five wires cable. Otherwise noise is generated in EXT and STOP cables by the induction from the power cable, which may cause wrong operation or failure of pump.

Installation

In case the pulse input is used.

The pulse input is used when the pump is operated by EXT mode.

The EXT mode means that the pump makes one shot per one external pulse signal. (Pump speed must be max. 6Hz = 360 spm or less.)

- When open collector signal is employed, pay attention to the polarity.
 - ④ EXT is plus(+) and ⑥ COM is minus(-). (Max. applied voltage 5V, Current 1.1mA)
- When the relay or like is used, employ the one of the minimum applicable load is 1mA or less designed for electronic circuit.

In case the stop function or the level sensor is connected.

The stop function means that the pump operation is stopped by the external potential free contact signal.

Connect wires to STOP and COM for both stop function and level sensor.

- In case the level sensor is open collector output, pay attention to the polarity. Pay attention to the polarity. ⑤ STOP is plus(+) and ⑥ COM is minus(-). (Max. applied Voltage 5V, Current 1.1mA)
- In case the level sensor is contact output, use the one of which the minimum applied load is 1mA or less designed for electronic circuit.

5) Insert the connector into the connector holder

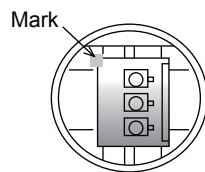

The connector and the holder have a mark to decide the direction. Insert the connector into the holder matching the marks.

The figure on the left shows the connector which is inserted into the holder.

6) Mount the connector holder to the pump body.

Turn a notch cut of holder to the operation panel direction of controller and insert the holder from the pump bottom, then securely tighten the lock nut.

Insufficient tightening will cause lowered waterproof ability.

Operation

<i>1.Bleeding.....</i>	<i>22</i>
<i>2.Flow rate Adjustment.....</i>	<i>24</i>
<i>3.Operation.....</i>	<i>25</i>
<i>4.Waterproof cover Mounting.....</i>	<i>29</i>

Operation

After the installation, piping, and wiring works are completed, operate the pump in accordance with the following steps.

CAUTION

- **Do not operate the pump with a completely closed discharge-side valve.**
Operating the pump with the discharge-side valve fully closed may lead to liquid leakage or pipe rupture. Make sure not to operate the pump with the discharge-side valve closed.
- **Do not run the pump dry.**
A pump which has been run dry may experience liquid leakage during its liquid feeding operation. Make it sure to run the pump after supplying liquid inside the pump.
 - * Dry operation of the pump for a long time (30 minutes or more) may cause the pump to overheat and the pump unit (pump head, valve case, etc.) to become deformed or the pump head attachment to become loose, which may result in liquid leakage trouble.
- **Do not adjust stroke length when pump stops.**
Adjust the stroke length adjusting dial while pump is running.
- **Keep the pump head firmly assembled.**
If the installation bolts on the pump head are loosened, liquid leakage may result.
 - * Fasten the 4 hex, socket bolts tightly before starting the initial pump operation. (The bolts may be loosened during storage or transportation of the pump, depending upon the condition of each.)
 - * Fastening torque: 2.2N·m for B11, 16, 21, C16, 21
2.6N·m for B31, C31
3.0N·m for C36Tighten all the bolts fully by applying an equal amount of torque in a diagonal order among the bolts.
- **When the setting of controller is completed, be sure to mount the waterproof cover. Note that the waterproof cover has a mounting direction. The waterproof property of IP67 is not maintained and the pump may break if the waterproof cover is mounted in wrong direction. In the last place fix the cover securely with six thumb bolts.**
- **If the control panel gets wet and liquid enters the controller, the pump may malfunction. Wipe the control panel immediately if it gets wet.**
Frequent ON and OFF of pump must be done by STOP function (ON and OFF to stop terminal). If you are forced to stop and start pump by turning ON and OFF of power source, max. permitted frequency is six times an hour.

1. Bleeding

Bleeding is a process undertaken to eliminate air inside the suction-side tube and the pump head. Make sure to carry out air elimination prior to the initial operation of the pump and/or after replacing the liquid in the tank. For safe bleeding, first set a hose to the air-vent port of the air vent unit.

WARNING

Some liquids used in pump feeding may cause skin trouble or affect the quality of a mechanical part. Wipe off the liquid immediately when it wets your hand or a mechanical part.

Operation

VC, VH, PC, PH, TC types

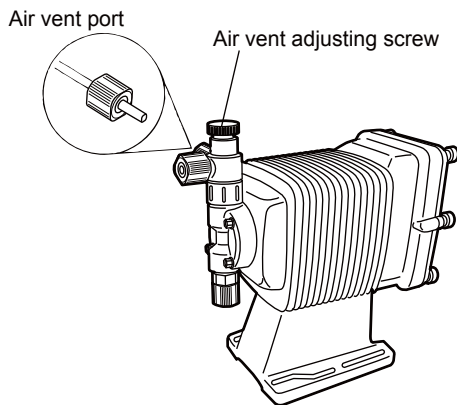

<Bleeding for EK-B11, 16, 21 and EK-C16, 21 models>

- [1] Start the pump. See the clause "Operation" to operate the pump.
- [2] Rotate the air vent adjusting screw counter-clockwise (almost half a turn) to open the air vent port.
- [3] Operate the pump under this condition for longer than 10 minutes for a complete removal of air.

SH type

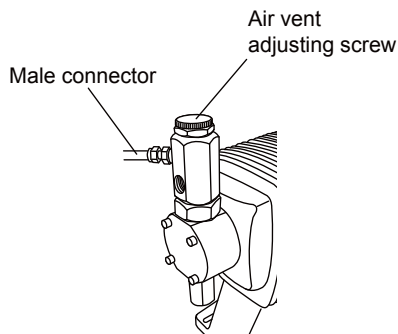

- [4] Rotate the air vent adjusting screw clockwise to close the air vent valve.
- [5] Check if liquid does not leak from any part.

<Bleeding for EK-B31·C31·C36>

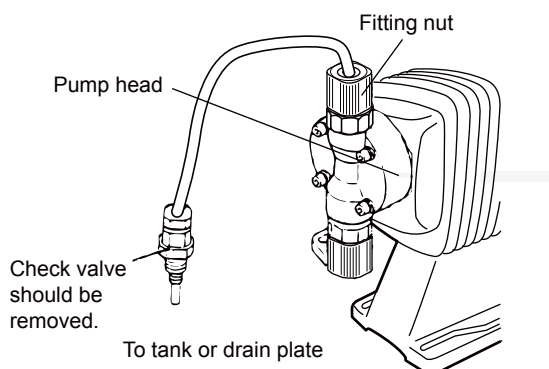

- [1] Extend the tube connected with the discharge-side fitting nut of the pump to the liquid tank or something like a drain plate. Then, start pump operation.
 - Remove the check valve if it is installed on the discharge-side.
- [2] Adjust the stroke rate to 360 spm, and continue operating the pump for about 10 minutes to eliminate the air completely.
- [3] When the air in the pump head is completely eliminated and replaced with liquid, return the discharge-side tube to the regular piping position.
- [4] Finally, make sure there is no leakage in any section.

Operation

2. Flow rate Adjustment

There are two ways to adjust the discharge capacity.

- A) Adjustment of stroke rate : Stroke speed (stroke per minute) is changed by the controller.
- B) Adjustment of stroke length : Stroke length is changed by stroke length adjusting dial to adjust the discharged capacity per stroke.

Basically the discharge capacity is adjusted by changing stroke rate with the stroke length fixed at 100% or so. Stroke length adjustment is used as auxiliary method to the fine adjustment which can not be done by the stroke rate adjustment. The compression ratio of the pump gets lower as the stroke length gets shorter, which causes the volumetric loss due to the bubbles and influence of pressure resulting in decreased discharged capacity.

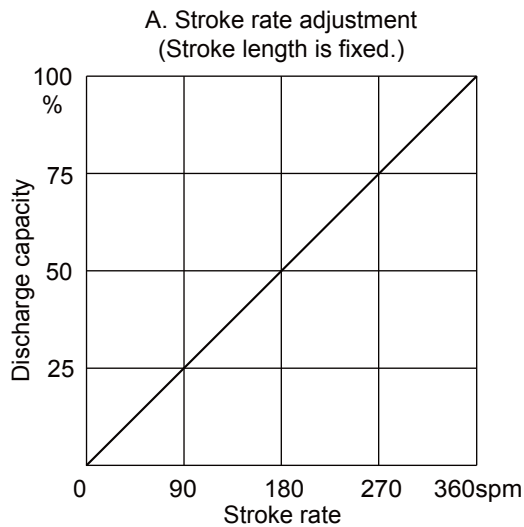

A. Adjustment of stroke rate

- 1) Refer to item 7-3. "Operation" for stroke rate adjusting method.

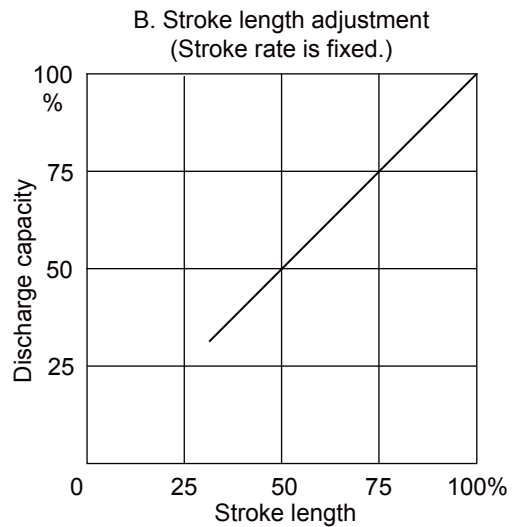

B. Adjustment of stroke length

- 1) Effective adjustment range of stroke length depends on pump model and type.
- 2) Stroke length adjustment should be done while pump is running.

In case discharge capacity is adjusted by changing stroke rate

- 1) When pumping gaseous liquid such as sodium hypochlorite (NaOCl) or hydrazine solution ($\text{N}_2\text{H}_2\text{O}_2$), stroke length must be fixed to 100% and adjust stroke speed to change flow capacity.

If stroke length is short, discharge capacity may be reduced.

- 2) If the back pressure of discharge side is high, stroke length should be fixed at 100% or near to adjust flow rate by changing stroke speed.

- 3) If the reaction is greatly influenced by the discharge capacity per shot in the application of neutralization or titration, adjust the discharge capacity by stroke speed with stroke length shortened to reduce the capacity per shot.

Operation

3. Operation

Control panel

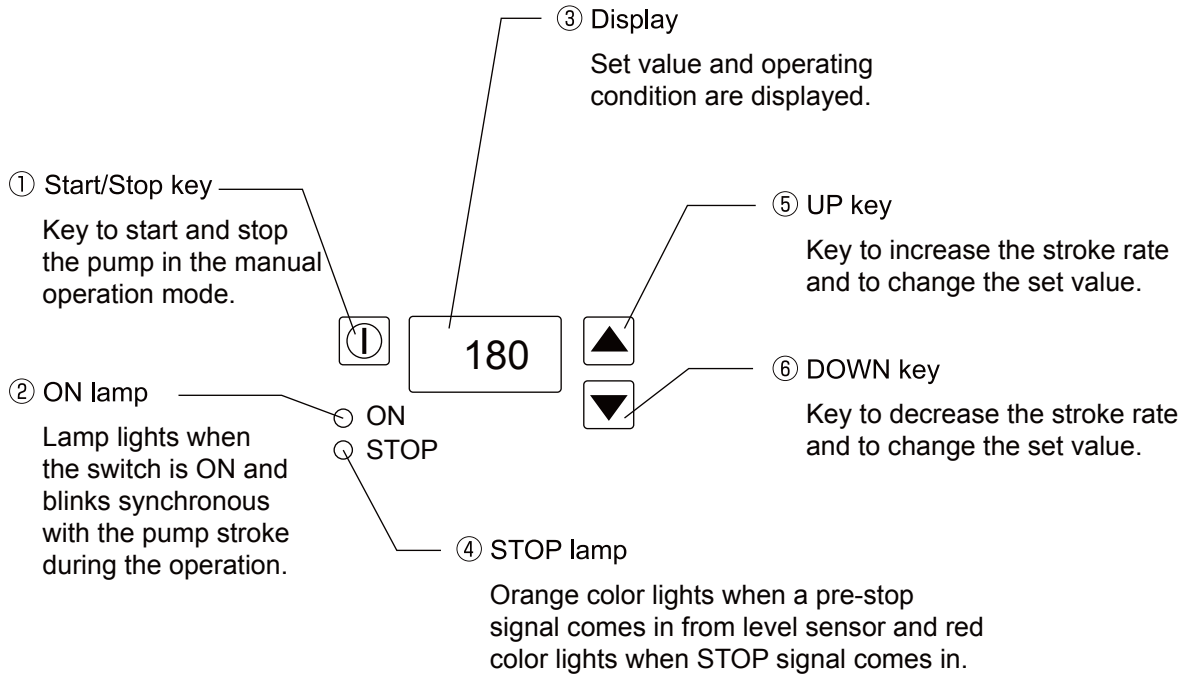

Basic display

180	Stroke rate is displayed.
EXT	EXT operation is displayed.
T-5	Display for chattering absorption function

Operation

Overview operating chart

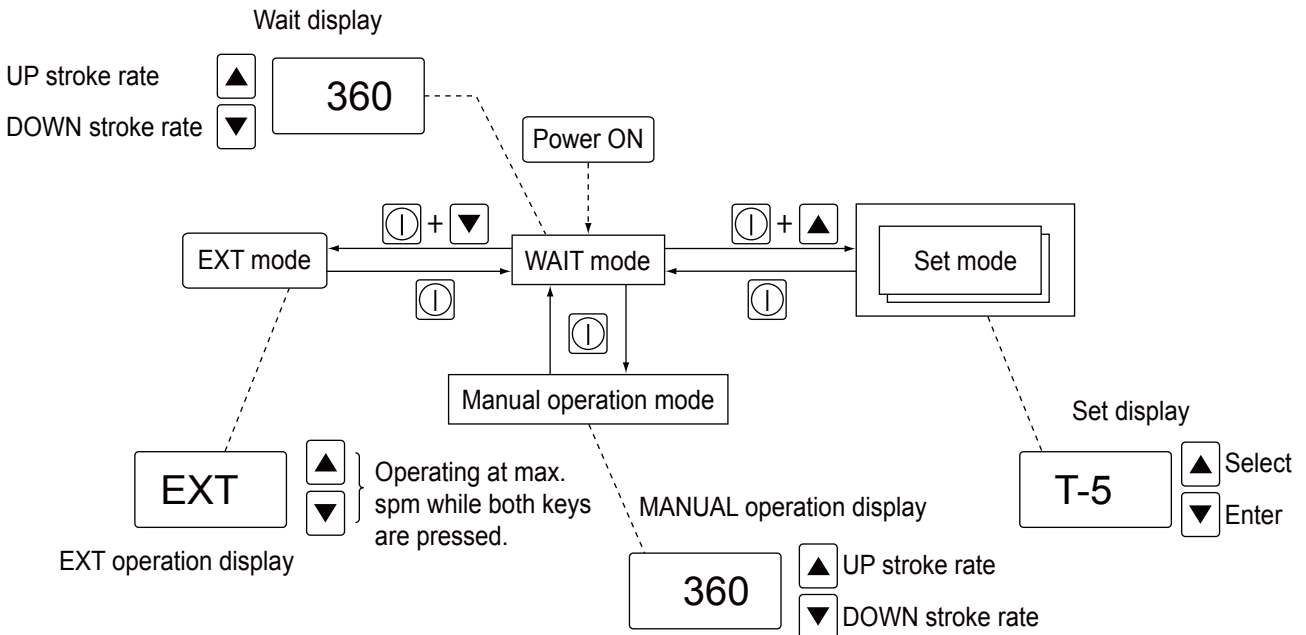

1. -----> means automatic move. After the program version is momentarily displayed, it automatically moves to the status at which the power is switched off last time. (When the power is ON for the first time, it comes to WAIT mode.)
2. For the manual operation, the pump starts when ① START/STOP key is pressed at WAIT mode. To stop the pump, it returns to WAIT mode when ① START/STOP key is pressed again.
3. For EXT operation, press ① START/STOP + ▼ keys at the same time to start the operation. For the stop of EXT operation, press ① key to come back to WAIT mode.
4. For the SET mode, press ① + ▲ keys at the same time. Setting is done by ▲ key, and press ▼ key to enter and to move to next setting.

Refer to following pages for details.

Operation

Operation Power ON

360

When the power is ON, the display comes to WAIT mode after program version is momentarily displayed. (When the power is switched on initially.)

Once the initial power is switched on, it comes to the mode at which the power was off last time. (In case the power was off at SET mode, WAIT mode comes first.)

· At the WAIT mode, stroke rate is displayed. ON lamp lights.

Manual operation

360

① Start and stop

To start manual operation at WAIT mode, press ① START/STOP key once. ON lamp blinks.

If ① START/STOP key is pressed again, ON lamp lights and it comes to WAIT mode.

② Change of stroke rate

Stroke rate is set by ▲ and ▼ keys. Press ▲ key to increase and ▼ key to decrease the figure. If the keys are pressed for more than 3 seconds, the figures change quickly. The change of stroke rate can be done while the pump is running or stopped. (WAIT mode)

65

EXT operation

360

EXT

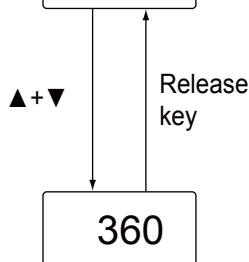

360

360

① Moving to WAIT mode

If it is in Manual operation mode or SET mode, make it WAIT mode once. If it is in WAIT mode, go to next.

② Moving to EXT mode

To move to EXT mode, press ① START/STOP and ▼ keys at the same time. In this EXT mode, the pump is operated automatically corresponding to external pulse signal.

③ Manual operation during EXT operation

Although EXT mode is automatic operation, the pump operates at 360 spm while ▲ and ▼ keys are pressed at the same time. If either one of keys is released, then it returns to EXT mode.

Use this way when you wish to do bleeding during EXT operation or when you wish to run pump while the pulse signal dose not come.

④ Moving to WAIT mode

Push ① START/STOP key to move to WAIT mode from EXT operation. When it comes to WAIT mode, the display shows the spm at which the MANUAL operation is done and the pump stops.

Operation

Setting of function

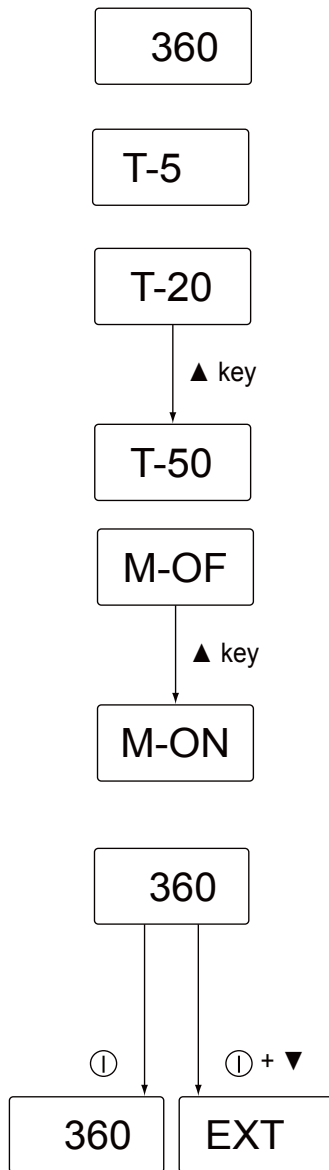

- ① Moving to WAIT mode
If it is in MANUAL operation or in SET mode, set to WAIT mode. If it is in WAIT mode, go to next step.
- ② Moving to SET mode
Push ① START/STOP and ▲ keys at the same time and it displays anti-chattering function.
- ③ Setting of anti-chattering function (NOTE)
Push ▲ key to change input pulse signal. Every time the key is pushed, the display changes to "T-5", "T-20" and to "T-50". Select the appropriate figure corresponding to the chattering condition of the signal. When no problem is found, select "T-5" (factory shipment status) and set the large figure for the noisy signal. Push ▼ key to move to next setting.
- ④ Setting of STOP function
"M - OF" and "M - ON" is displayed alternatively every time when ▲ key is pressed. To stop the pump by closing the contact when the signal enters, select "M - OF" and select "M - ON" to stop the pump by opening the contact when the signal enters.
If ▼ key is pushed here, it comes to the mode of anti-chattering function setting and if ① START/STOP key is pushed, it comes to WAIT mode.
- ⑤ Moving to WAIT
Push ① START/STOP key once to come back to WAIT mode.
When WAIT mode comes, the display shows the spm of MANUAL operation and the pump stops.
- ⑥ Operation
Start the pump operation when the function setting is completed.
Push ① START/STOP key once for MANUAL operation.
Push ① START/STOP and ▼ keys at the same time for EXT operation.

(NOTE)

The chattering means that one pulse is recognized as several pulses due to the disordered wave caused by the noise. When the chattering happens, the timing should be adjusted to recognize the pulse so that the correct counting can be done in spite of the disordered pulse.

⚠ CAUTION

1. The larger the set figures of anti-chattering, the stronger against disordered input pulses but the more difficult to read the short ON time. The set figures (5, 20 and 50) show approx. time (msec) to recognize pulses. ON time of input pulse should be larger than the chattering figures.
2. If used combined with other IWAKI electronic pump controller, set at T-5. Pump may not operate if set at T-20 or T-50.

Parameters

Following table shows the parameters and setting range for each mode.

Model	Parameter	Initial value	Setting range
MANUAL	SPM	360 spm	1 - 360 spm (by one spm)
SET	Chattering	T - 5	T-5, T-20, T-50
	STOP	M - OF	M - OF, M - ON

Operation

4. Waterproof cover Mounting

The waterproof property of IP67 is maintained as long as the waterproof cover is properly mounted. When you finish the adjustment of stroke length and setting of controller, mount the cover at correct direction and fix it securely with six thumb bolts.

⚠ CAUTION

1. If the pump is used without the waterproof cover or with the cover wrongly mounted, the waterproof property of IP67 is not maintained resulting in pump failure. Water tightness is not maintained either when the six bolts are not tightened securely.
2. The waterproof cover has the direction for mounting. Mount the cover in the direction so that you can read "IWAKI" mark shown on the cover. When the cover is mounted upside down, you can not tighten two bolts in the centre among six bolts.

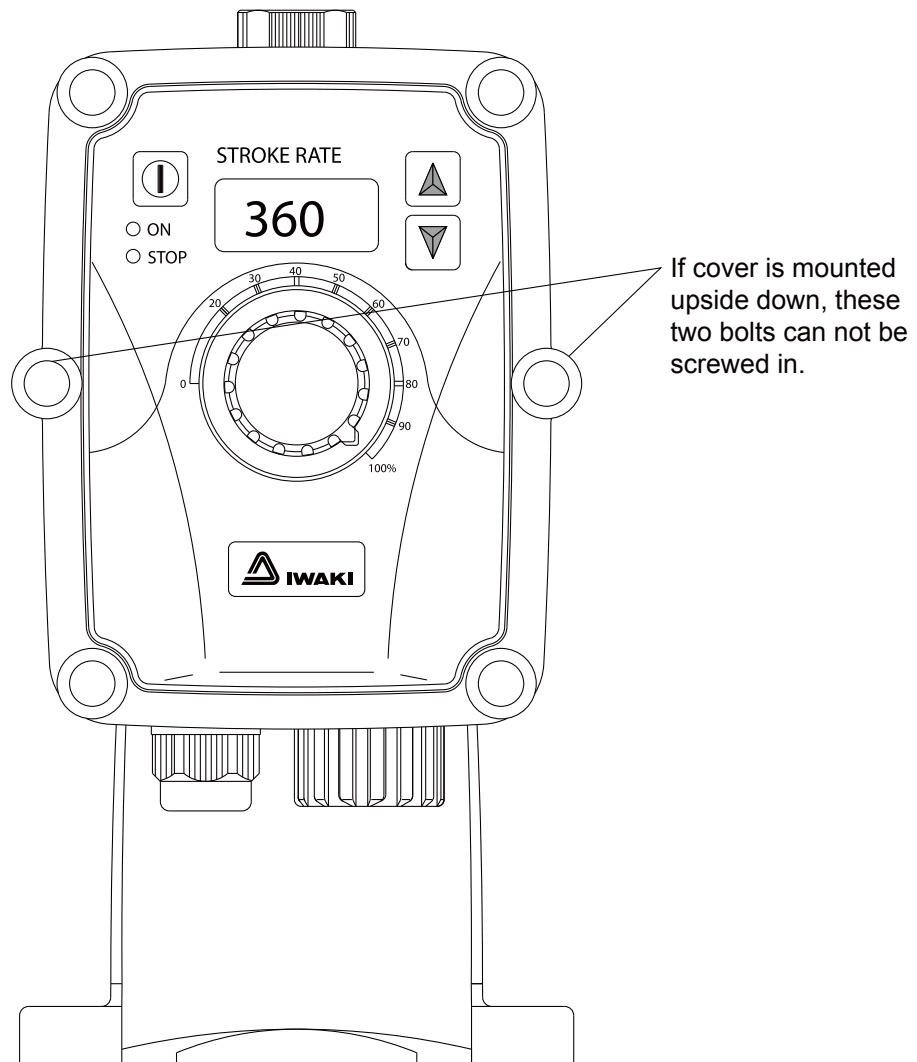

Maintenance

<i>1.Troubleshooting.....</i>	<i>31</i>
<i>2.Maintenance & Inspection.....</i>	<i>32</i>
<i>3.Wear Parts.....</i>	<i>33</i>
<i>4.Disassembly & Assembly.....</i>	<i>34</i>
<i>5.Exploded View.....</i>	<i>38</i>
<i>6.Accessories.....</i>	<i>42</i>

Maintenance

Instruction for safety

Any work related to maintenance, inspection, dismantlement and assembly should be done according to this instruction manual. Do not handle the pump beyond the instruction shown on this manual.

⚠ WARNING

• Wear protector

Coming in contact with a hazardous liquid can lead to serious injury. Always wear protective clothing such as protective goggles, cap, and gloves during maintenance and inspection work.



Wear protective gear

• Turn off power

Risk of electrical shock. Do not work on the pump or system while they are powered. Always stop the pump by pushing START/STOP key 3 seconds before unplugging the power cord. If the power cord is unplugged within 3 seconds, the controller may not store the last key operation "pushing START/STOP key". In this case the pump can start to run as it is powered.



Power off

1. Troubleshooting

Trouble	Cause	Troubleshooting
Pump does not start.	<ul style="list-style-type: none"> • Faulty wiring or disconnection. • Voltage is too low. • The electronic circuit of the control unit is damaged. 	<ul style="list-style-type: none"> ○ Correct wiring. ○ Determine a cause and regain a specified voltage. ○ Replace the whole unit.
The pump does not suck a liquid	<ul style="list-style-type: none"> • Air suction on suction piping. • Valve gasket is not installed. • Valve set is mounted in wrong direction. • Pump is air-locked. • Pump stroke length is too short. • Suction-side/discharge-side valve is clogged with foreign matters. • Valves cling to valve seat. 	<ul style="list-style-type: none"> ○ Eliminate air suction. ○ Install the valve gasket. ○ Mount the valve set in correct direction. ○ Carry out air elimination. ○ Drive the pump at 100% stroke length. Then finely adjust stroke length. ○ Dismantle, inspect, and clean it. ○ Dismantle, inspect, and clean it.
The flow fluctuates.	<ul style="list-style-type: none"> • Suction-side/discharge-side valve is clogged with foreign matters. • Air is trapped in the pump. • Overfeeding • Diaphragm is damaged. 	<ul style="list-style-type: none"> ○ Disassemble, inspect, and clean it. ○ Carry out air elimination. ○ Install a check valve. ○ Replace diaphragm.
Liquid leaks.	<ul style="list-style-type: none"> • Connections are not secured. • The pump head is not fixed enough. • Diaphragm is damaged. • O ring or valve gasket is not installed. 	<ul style="list-style-type: none"> ○ Tighten each connection again. ○ Tighten the pump head. ○ Replace diaphragm. ○ Install O ring and valve gasket.

Torque: 2.16 N•m
(B11 • 16 • 21
• C16 • 21)
: 2.55 N•m
(B31 • C31 • 36)

Maintenance

2. Maintenance & Inspection

Stop the pump immediately when detecting any abnormality in a daily inspection. Take measures according to "Troubleshooting" section. When wear parts come to the life limit, replace them by new ones. Refer to "Wear parts" section.

No.	Daily inspection	Description	How to Check
1	Does the pump lift liquid without problems?	<ul style="list-style-type: none"> ● Is liquid being pumped? ● Is suction /discharge pressure at normal level? ● Are there quality change, crystallization, or solidification for liquid? 	<ul style="list-style-type: none"> ○ Use flow meter or visual inspection. ○ Check nameplate. ○ By visual inspection.
2	Abnormal noise or vibration?	<ul style="list-style-type: none"> ● Abnormal noise or vibration may take place when the pump runs abnormally. 	<ul style="list-style-type: none"> ○ By visual and audio inspection
3	Is there liquid leakage or air suction at any joint on the pump or piping?	<ul style="list-style-type: none"> ● Tighten the joint where leakage takes place. ● Excessive air bubbles in discharged liquid mean air suction takes place in system. Check the piping and tighten loose joints. 	<ul style="list-style-type: none"> ○ By visual inspection ○ By visual inspection

! Check if the pump head mounting bolts are not loosened every 3 months. Tighten them diagonally on the following tightening torques as necessary. The mounting bolts may loosen during operation (An extent of looseness depends on operating condition.).

Tightening torque of the pump head mounting screw





Torque	Torque	Parts name
EK-B11 • 16 • 21	2.16N • m	M4 hex. socket head bolts
EK-B31	2.55N • m	M4 hex. socket head bolts
EK-C16 • 21	2.16N • m	M4 hex. socket head bolts
EK-C31	2.55N • m	M4 hex. socket head bolts
EK-C36	2.55N • m	M5 hex. socket head bolts

Maintenance

3. Wear Parts

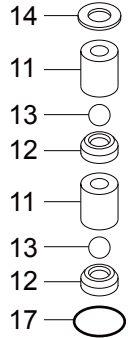
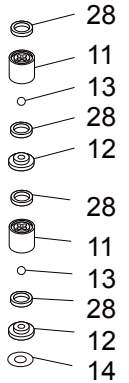
If the pump is operated for a long period, it is necessary to replace the expendable parts.
It is recommended you always stock the following expendable parts.

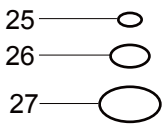
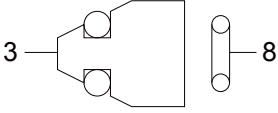
Diaphragm type

		Parts		Quantity/unit	Time to be replaced	
Pump	Valve unit	VC, VH, PC, PH, TC 	SH 	2 units	8,000 hours	
	Diaphragm					1
	O ring		—			1
Check valve	Poppet for check valve with O ring			1		
	Spring			1		

Time to be replaced is a reference and it depends on the liquid handled and operating condition.

Maintenance

4. Disassembly & Assembly

⚠ WARNING

- Pay special attention to the presence of residual liquid inside the pump when disassembling the pump.
- Wash the wet-end parts in the pump head with water.

Diaphragm and high viscosity types

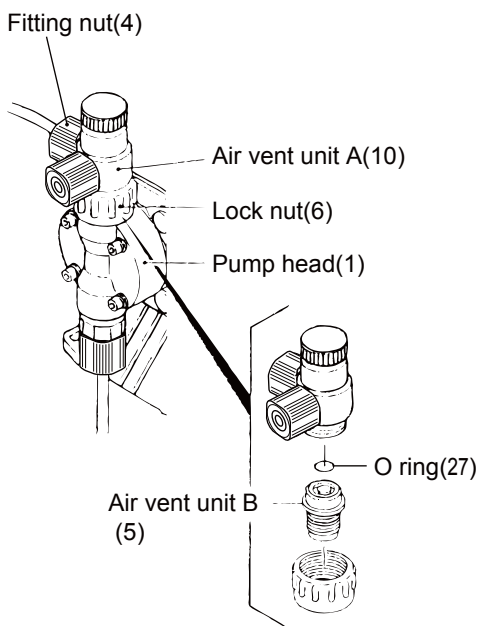

EK-B31, C31, C36

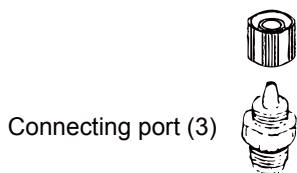

■ Replacement of valve set for wet-end material symbols VC, VH, PC, PH, TC (Refer to exploded view on Page 39)

<Disassembly>

[1] Removal of the valve set on the discharge side

- (1) Loosen the fitting nut (4) and detach the tube to the pump. Pay attention to any residual liquid which may flow out of the end of the disconnected tube.
- (2) Use a pair of pliers or similar tool to turn the lock nut (6) counterclockwise (seen from top) to remove the air vent unit A (10).
- (3) Use a wrench to loosen and remove the air vent unit B (5). Then, take the valve set out of the pump head.
 - In the case of EK-B31, C31, C36 type, use a wrench to loosen and remove the connecting port (3). Then, take the valve set out of the pump head.

Maintenance

[2] Removal of the valve set on the suction side.

Loosen the fitting nut (4) and detach the tube from the pump.

- Pay attention to the residual liquid which may flow out of the end of the disconnected tube.
- Use a wrench to loosen and remove the connecting port (3).
- If any element of the valve set thus removed is scratched or worn, replace it with a new one.

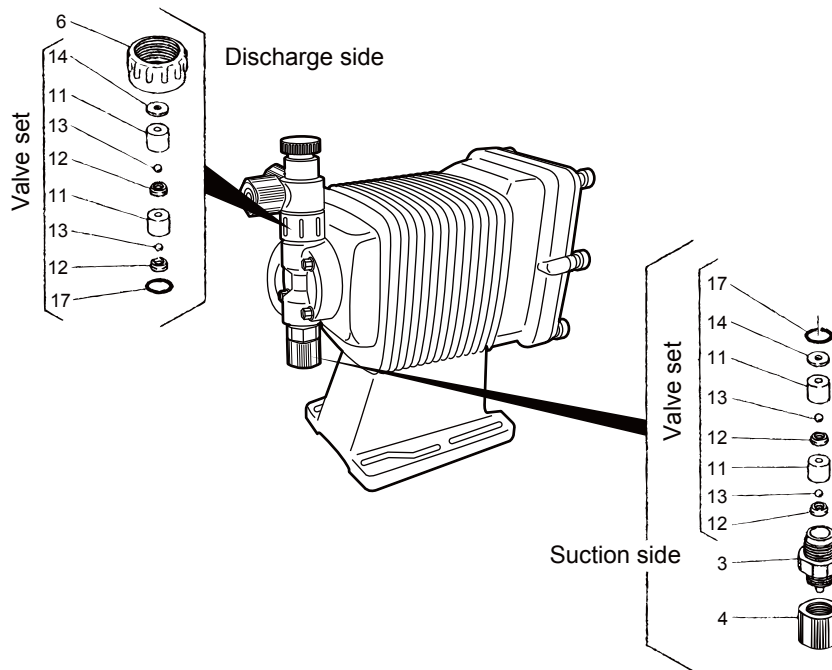

<Assembly>

Assemble the pump by following the disassembly sequence in reverse. Carefully monitor the following points to achieve a perfect assembly.

- Be careful to the assembly positions and directions of the parts.
If the elements of the valve set are inserted in incorrect positions and/or directions, an abnormal liquid flow may result, for example liquid leaks or a reduction in discharge amount.
- Do not forget to insert the O ring (17) or valve gasket (14).

[3] Assembly of the valve set on the discharge side

Position the valve set on the pump head. Then, insert the lock nut (6) into air vent unit B (10) and fasten the lock nut.

[4] Assembly of the valve set on the suction side

Position the valve set on the connecting port (3) and fasten the connecting port by hand. Next, use a wrench to rotate the connecting port about 1/4 turn for further tightening.

Maintenance

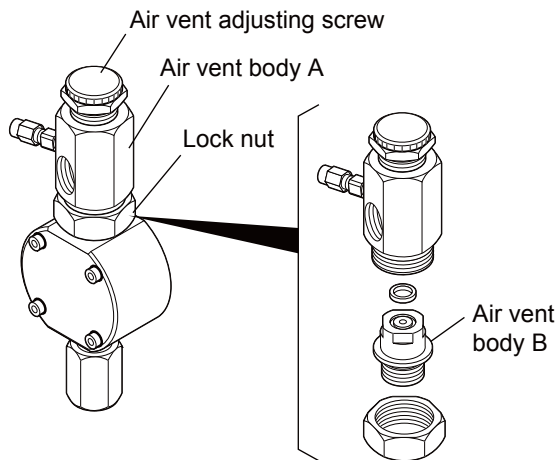

■ Replacement of valve set for wet-end material code SH (Refer to exploded view on page 40.)

<Disassembly of discharge valve>

- 1) Remove every hose and pipe.
- 2) Turn the lock nut to left with wrench to remove air vent body.
- 3) Loosen the air vent body B with wrench to remove it.
- 4) Remove the valve set with tweezers from pump head.

<Disassembly of suction valve>

Loosen the connection port with wrench to remove it and remove the valve set with tweezers.

⚠ CAUTION

Pay attention not to drop the valve set.

<Assembly of discharge valve set>

Put the valve set into pump head and screw in the air vent body B after lock nut is put on it.

<Assemble of suction valve set>

Put the valve set in the connection port, screw it into pump head by hand and tighten it by wrench by turning it by one fourth turns.

⚠ CAUTION

Pay attention not to put the parts in wrong order and upside down. Wrong mounting of parts will cause failed pumping or abnormal pressure increase.

⚠ CAUTION

Do not forget to put O ring and gasket.

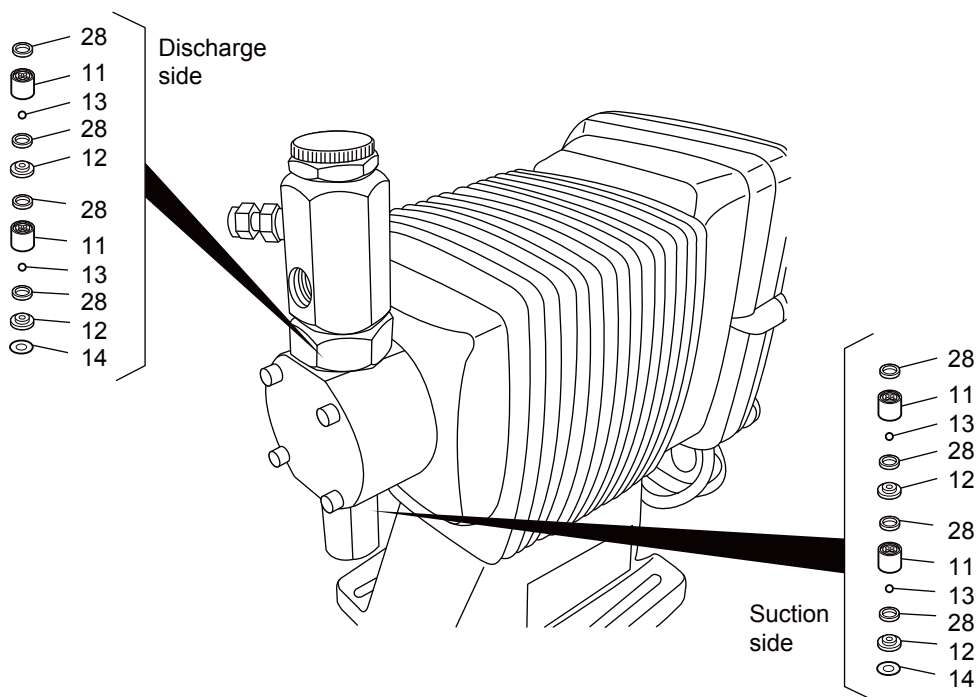

Maintenance

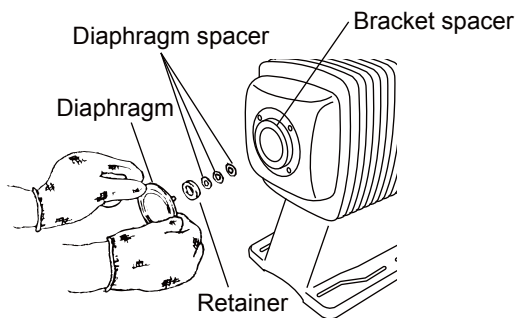
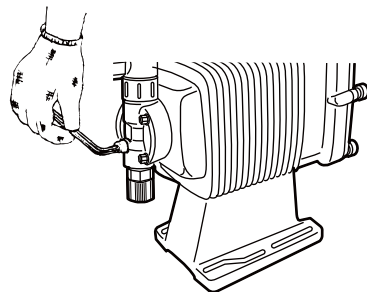
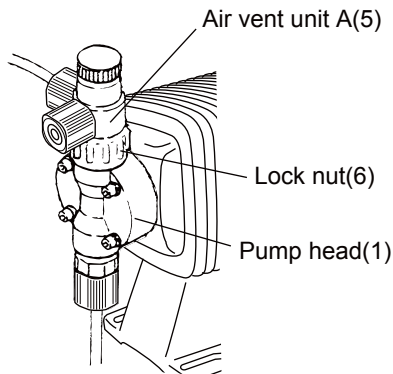

■ Air vent assembly

Use a wrench to loosen the lock nut(6). Since the air vent unit(A) can be rotated 360 degrees, the tube connection position can be selected freely to satisfy your requirements. The lock nut shall be loosened to make sure that the tube is not positioned over the pump head. Then, fix the position by fastening the lock nut. When fastening the lock nut, hold the air vent valve A with your hand and rotate the lock nut by hand clockwise when viewed from the top of pump unit. Then, use a wrench to rotate the lock nut about 1/4 turn for further tightening.

■ Replacement of diaphragm

<Disassembly>

- [1] Loosen the four hex socket bolts with a hexagon L-shaped wrench to detach the pump head from the pump body.
- [2] Operate the pump to adjust the stroke length to 0%.
- [3] Hold the periphery of the diaphragm and rotate the diaphragm counterclockwise to detach it from the plunger pin.

· In some cases, some diaphragm spacers are inserted behind the diaphragm and retainer for positioning purpose. (In some cases the pumps are equipped with no spacers). Be careful not to misplace them when replacing the diaphragm.

<Assembly>

To assemble the diaphragm, follow the disassembly sequence in reverse, paying attention to the following points.

- [1] Prior to reassembly, set the pump stroke length at 0%.
 - First, start the pump for stroke length setup. Then, stop the pump and disconnect the power supply.
- [2] Insert the retainer and diaphragm spacers into the screwed section of a new diaphragm and screw the diaphragm onto the plunger pin.
 - Face the round side of the retainer to the diaphragm. Do not allow the bracket spacer to come off. If the bracket spacer comes off, fit it into the bracket, mating their concavoconvex. (EK-□11-21)
- [3] Attach the pump head onto the pump body. Tighten the four hex socket bolts by applying an equal amount of torque to them.
 - Refer to "Maintenance & Inspection" on page 32 for the tightening torque.

Maintenance

5. Exploded View

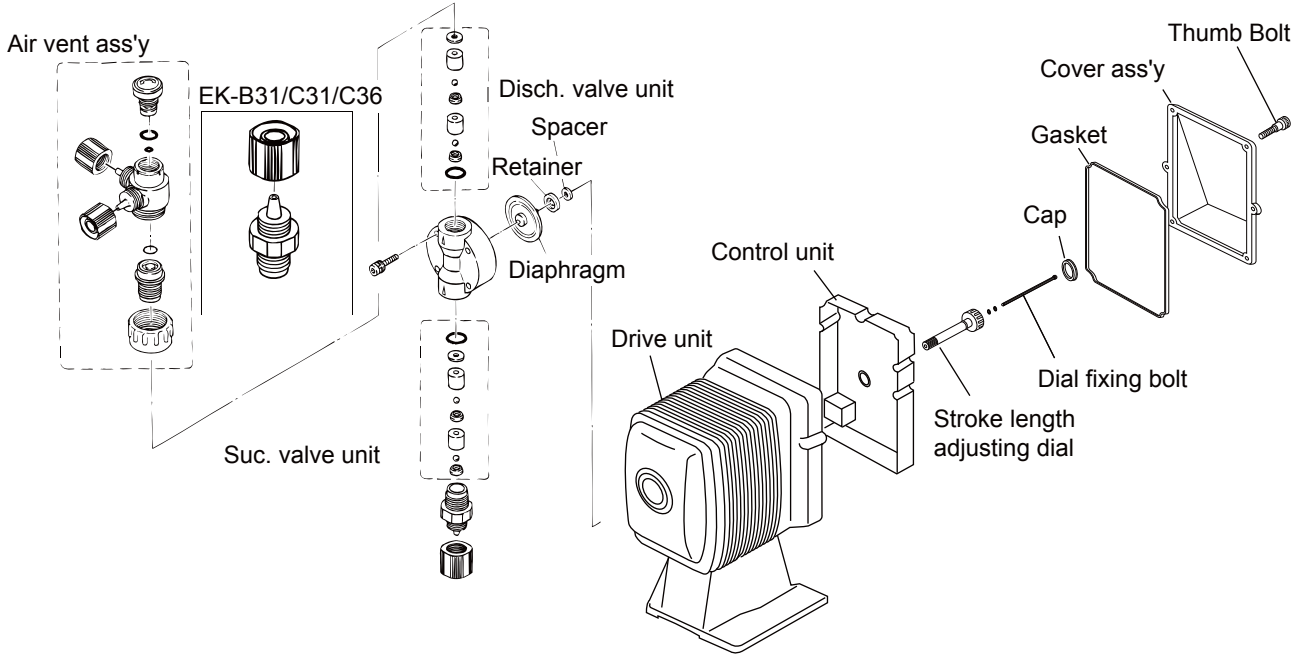

Maintenance

■ Pump Unit

- EK-B11, B16, B21, C16, C21 (VC, VH, PC, PH, TC)

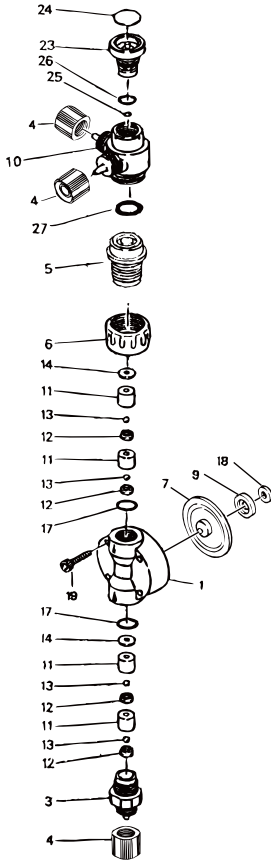

No.	Parts name	Quantity
1	Pump head	1
3	Fitting	1 (2)
4	Fitting nut	3 (2)
5	Air vent body B	1(0)
6	Lock nut	1(0)
7	Diaphragm	1
9	Retainer	1
10	Air vent body A	1(0)
11	Valve guide	4
12	Valve seat	4
13	Valve	4
14	Valve gasket	2
17	O ring	2
18	Diaphragm spacer	(NOTE 1)
19	Hex. socket cap bolt (with SW, PW)	4
23	Adjusting screw	1(0)
24	Name plate	1(0)
25	O ring	1(0)
26	O ring	1(0)
27	O ring	1(0)

■ EK-B31, C31, C36 (VC, VH, PC, PH, TC)

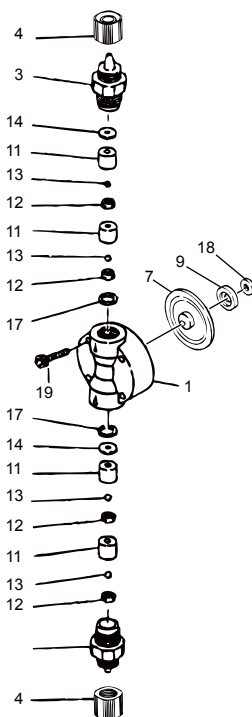

NOTE 1: The number of the diaphragm spacers, which are for dimensional adjustment, depend on the type of pump.

2: Quantity in parentheses is for EK-B31, C31, C36.

Maintenance

- EK-B11, B21, C21, C31, C36 (SH)

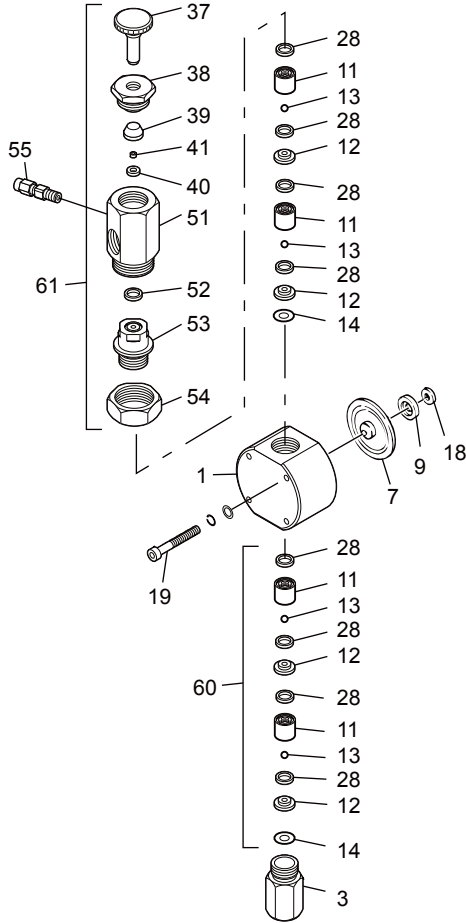

No.	Parts name	Q'ty
1	Pump head	1
3	Fitting	1
7	Diaphragm	1
9	Retainer	1
11	Valve guide	4
12	Valve seat	4
13	Valve	4
14	Valve gasket B	2
18	Diaphragm spacer	(NOTE)
19	Hex. socket cap bolt (with SW, PW)	4
28	Valve gasket A	8
37	Adjusting screw	1
38	Seal nut	1
39	Seal ring	1
40	Seat	1
41	Seat ring	1
51	Air vent body A	1
52	Gasket	1
53	Air vent body B	1
54	Nut	1
55	Male connector	1

NOTE : The number of the diaphragm spacers, which are for dimensional adjustment, depend on the type of pump.

Maintenance

■ Check valve (CA-1, CA-2)

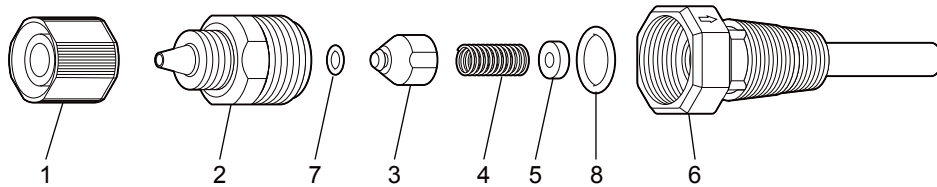

No.	Name	Quantity
1	Fitting nut	1
2	Check valve body	1
3	Poppet valve	1
4	Spring	1
5	Spacer	1
6	Valve Fitting A	1
7	O ring	1
8	O ring	1

Maintenance

6. Accessories

■ Specification of check valve(CA, CS), back pressure valve(BVC) (Optional Items)

Type	Set Pressure MPa	Diameter of Fitting mm	Material of Liquid Contacting Parts	Applicable Pump	Material Code of Liquid Contacting Parts of Pump	
CA-1V-4	0.17 ^{+0.05} _{-0.04}	∅ 4 × ∅ 9	CFRPP	EK-B11, B16, B21 C16, C21	PC	
CA-1E-4					PH	
CA-1V-6		∅ 6 × ∅ 8			PC	
CA-1E-6					PH	
CA-1V-4 × 6		∅ 4 × ∅ 6			PC	
CA-1E-4 × 6					PH	
CA-2V-8	0.17 ± 0.04	∅ 8 × ∅ 13		EK-C31	PC	
CA-2E-8		∅ 9 × ∅ 12			PH	
CA-2V-9					PC	
CA-2E-9		PH				
CA-2VL-8	0.05 ^{+0.04} _{-0.03}	∅ 8 × ∅ 13		EK-B31, C36	PC	
CA-2VE-8					PH	
CA-2VL-9		∅ 9 × ∅ 12	PC			
CA-2EL-9			PH			
CA-1VC-4	0.17 ± 0.04	∅ 4 × ∅ 9	PVC		EK-B11, B16, B21 C16, C21	VC
CA-1VE-4						∅ 4 × ∅ 6
CA-1VC-4 × 6		VC				
CA-1VE-4 × 6		VH				
CA-1VC-6		∅ 6 × ∅ 8		VC		
CA-1VE-6				VH		
CA-2VC-8		∅ 8 × ∅ 13		EK-C31	VC	
CA-2VE-8					VH	
CA-2VC-9					VC	
CA-2VE-9					VH	
CA-2VCL-8		0.05 ^{+0.04} _{-0.03}		∅ 8 × ∅ 13	EK-B31, C36	VC
CA-2VEL-8						VH
CA-2VCL-9	∅ 9 × ∅ 12		VC			
CA-2VEL-9			VH			
BVC-1VV-4H	0.2 ± 0.02	∅ 4 × ∅ 6	EK-B11, B16, B21 C16, C21	VC		
BVC-1VV-9H		0.10 ^{+0.02} _{-0.01}				∅ 9 × ∅ 12
	EK-B31, C36					
BVC-1TV-4H	0.2 ± 0.02	∅ 4 × ∅ 6	EK-B11, B16, B21 C16, C21			TC
BVC-1TV-10H		0.10 ^{+0.02} _{-0.01}		∅ 10 × ∅ 12	EK-C31	
	EK-B31, C36					
CS-1S	0.2 ± 0.03	Rc 1/4	SUS316	EK-B11, B16, B21 C16, C21, C31	SH	
CS-1SL	0.05 ± 0.03					EK-B31, C36



IWAKI CO.,LTD. 6-6 Kanda-Sudacho 2-chome Chiyoda-ku Tokyo 101-8558 Japan

TEL:(81)3 3254 2935 FAX:3 3252 8892(<http://www.iwakipumps.jp>)

U.S.A. : IWAKI America Inc.	TEL : (1)508 429 1440 FAX : 508 429 1386	Germany : IWAKI EUROPE GmbH	TEL : (49)2154 9254 0 FAX : 2154 1028
Australia : IWAKI Pumps Australia Pty. Ltd.	TEL : (61)2 9899 2411 FAX : 2 9899 2421	Italy : IWAKI Italia S.R.L.	TEL : (39)02 990 3931 FAX : 02 990 42888
Singapore : IWAKI Singapore Pte. Ltd.	TEL : (65)763 2744 FAX : 763 2372	Denmark : IWAKI Pumper A/S	TEL : (45)48 24 2345 FAX : 48 24 2346
Indonesia : IWAKI Singapore (Indonesia Branch)	TEL : (62)21 690 6607 FAX : 21 690 6612	Sweden : IWAKI Sverige AB	TEL : (46)8 511 72900 FAX : 8 511 72922
Malaysia : IWAKIm Sdn. Bhd.	TEL : (60)3 7803 8807 FAX : 3 7803 4800	Finland : IWAKI Suomi Oy	TEL : (358)9 2742714 FAX : 9 2742715
Taiwan : IWAKI Pumps Taiwan Co., Ltd.	TEL : (886)2 8227 6900 FAX : 2 8227 6818	Norway : IWAKI Norge AS	TEL : (47)66 81 16 60 FAX : 66 81 16 61
Thailand : IWAKI (Thailand) Co.,Ltd.	TEL : (66)2 320 1303 FAX : 2 322 2477	France : IWAKI France S.A.	TEL : (33)1 69 63 33 70 FAX : 1 64 49 92 73
Hong Kong : IWAKI Pumps Co., Ltd.	TEL : (852)2 607 1168 FAX : 2 607 1000	U.K. : IWAKI PUMPS (UK) LTD.	TEL : (44)1743 231363 FAX : 1743 366507
China : GFTZ IWAKI Engineering & Trading Co., Ltd.	TEL : (86)20 8435 0603 FAX : 20 8435 9181	Switzerland : IWAKI (Schweiz) AG	TEL : (41)32 3235024 FAX : 32 3226084
China : IWAKI Pumps Co., Ltd. (Beijing office)	TEL : (86)10 6442 7713 FAX : 10 6442 7712	Austria : IWAKI (Austria) GmbH	TEL : (43)2236 33469 FAX : 2236 33469
China : IWAKI Pumps (Shanghai) Co., Ltd.	TEL : (86)21 6272 7502 FAX : 21 6272 6929	Holland : IWAKI Holland B.V.	TEL : (31)297 241121 FAX : 297 273902
Philippines : IWAKI Chemical Pumps Philippines, Inc.	TEL : (63)2 888 0245 FAX : 2 843 3096	Spain : IWAKI Iberica Pumps, S.A.	TEL : (34)943 630030 FAX : 943 628799
Korea : IWAKI Korea Co.,Ltd.	TEL : (82)2 3474 0523 FAX : 2 3474 0221	Belgium : IWAKI Belgium n.v.	TEL : (32)1430 7007 FAX : 1430 7008
Vietnam : IWAKI Pumps Vietnam Joint Venture Co.,Ltd.	TEL : (84)613 933456 FAX : 613 933399		

T655 '07/10