

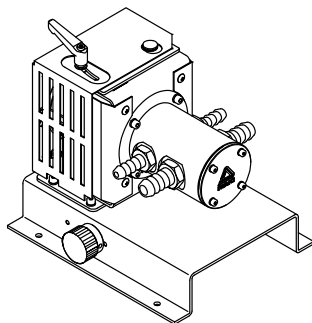

Iwaki Hicera Pump

V-25 (coupling connection type)



Instruction manual

Thank you for choosing our product.

 Please read through this instruction manual before use.

This instruction manual describes important precautions and instructions for the product. Always keep it on hand for quick reference.

Contents

Order Confirmation.....	2
Safety Instructions	2
WARNING	2
CAUTION	3
Precautions for Use.....	4
Overview	5
Part Names	5
Identification Codes	6
Installation	6
Pump Mounting	6
Plumbing	7
Main port.....	7
Flushing port	8
Wiring	9
Motor wiring.....	9
Sensor wiring	9
Operation	10
Starting the pump	10
Stoppage.....	10
Supportive operation	11
Inching (with a reversible motor)	11
Recovery run (with a stepper motor)	11
Maintenance	12
Troubleshooting.....	12
Inspection	13
Daily inspection.....	13
Greasing (plunger pin).....	13
Wear Part Replacement	14
Wear part list.....	14
Exploded view.....	14
Disassembly & Assembly	15
Specifications/Outer Dimensions	18
Specifications.....	18
Outer dimensions.....	19
EC DECLARATION OF CONFORMITY	19

Order Confirmation

a. Check the nameplate to see if the information such as model codes is as ordered.

(A coupling and motor are not provided. Purchase separately.)

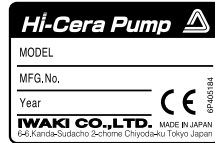

Spec label for the European market

b. Check for transit damage and loose bolts.

*The CE marking on our product(s) is for us to market the product(s) into the European market, however, the CE marking does not ensure any safety or conformity of the product(s) outside the European market.

When the pump is incorporated into the equipment marketed in the European market, such equipment must meet all the requirements of applicable directives.

In such a case, any person who places the equipment on the market must carry a CE mark on the equipment as a manufacturer.

*This product, in the state of the pump without a motor, is compliant with the Machinery Directive 2006/65/EC and the RoHS Directive 2011/65/EU. When this product is equipped with a motor, a customer, a user, or any party that will use the complete pump unit must conform it to necessary standards such as the EMC Directive 2014/30/EU and the Low Voltage Directive 2014/35/EU.

Safety Instructions

Read through this section before use. This section describes important information for you to prevent personal injury or property damage.

■ Symbols

 **WARNING** Indicates mishandling could lead to a fatal or serious accident.

 **CAUTION** Indicates mishandling could lead to personal injury or property damage.

Export Restrictions

Technical information contained in this instruction manual might be treated as controlled technology in your countries, due to agreements in international regime for export control. Please be reminded that export license/permission could be required when this manual is provided, due to export control regulations of your country.

WARNING

Turn off power before service

Risk of electrical shock. Be sure to turn off power to stop the pump and related devices before service is performed.



Turn Off Power

Stop operation

If you notice any abnormal or dangerous conditions, suspend operation immediately and inspect/solve problems.



Do not use the pump in any condition other than its intended purpose

The use of the pump in any conditions other than those clearly specified may result in failure or injury. Use this product in specified conditions only.



Prohibited

Do not modify the pump

Alterations to the pump carries a high degree of risk. It is not the manufacturer's responsibility for any failure or injury resulting from alterations to the pump.



Do not rework or alter

Wear protective clothing

Always wear protective clothing such as an eye protection, chemical resistant gloves, a mask and a face shield during disassembly, assembly or maintenance work. The specific solution will dictate the degree of protection. Refer to SDS precautions from the solution supplier.



Wear protectors

Do not damage the power cable

Do not pull, knot, or crush the power cable. Damage to the power cable could lead to a fire or electrical shock if cut or broken.



Caution

Do not use the pump without a cover of rotating area

A spinning coupling can catch your hands or clothes. Install a coupling cover over the coupling before operating a pump. (A coupling cover is not provided. Purchase separately.)



Prohibited

CAUTION

Qualified personnel only

The pump should be handled or operated by qualified personnel with a full understanding of the pump. Any person not familiar with the product should not take part in the operation or maintenance of the pump.



Do not run pump dry

Do not run pump dry for more than 3 minutes. Otherwise, friction heat may build up and the plunger may seize in the cylinder. Optimise your system and eliminate the possibility of dry running.



Caution

Do not close a suction or a discharge line in operation

Closed-suction/-discharge operation may damage the pump and piping.



Prohibited

Keep electric parts and wiring dry

Risk of fire or electric shock. Install the pump where it can be kept dry.



Prohibited

Ventilation

Fumes or vapours can be hazardous with certain solutions. Ensure proper ventilation at the operation site.



Caution

Do not install or store the pump:

- In a flammable atmosphere.
- In a dusty/humid environment.
- Where ambient temperature can exceed 0-40°C (32-104°F)
- In direct sunlight or wind & rain.



Prohibited

Spill precautions

Ensure protection and containment of solution in the event of plumbing or pump damage (secondary containment).



Shaft alignment

When connecting a pump and motor through a coupling, follow instructions on page 7.



Preventative maintenance

Follow instructions in this manual for replacement of wear parts. Do not disassemble the pump beyond the extent of the instructions.



Do not use a damaged pump

Use of a damaged pump could lead to an electric shock or death.



Prohibited

Disposal of a used pump

Dispose of any used or damaged pump in accordance with local rules and regulations. If necessary, consult a licensed industrial waste disposal company.



Install a relief valve

Install a relief valve to depressurize a discharge line. The set pressure of the relief valve must not exceed the maximum allowable pressure of the discharge line.



Precautions for Use

- Anchor the pump with four M6 bolts.
 - When two or more pumps are installed together, vibration may be significant, resulting in poor performance or failure. Select a solid foundation (concrete) and fasten anchor bolts securely to prevent vibration during operation.
 - Allow sufficient space around the pump for easy access and maintenance.
 - Install the pump as close to the supply tank as possible.
 - Observe the maximum suction lift of 2 meters/6.56feet (with clean water). Note it varies with liquid characteristics.
 - This pump can deliver a viscous liquid exceeding 500mPa·s if the motor speed is low enough. Contact us or your dealer.
 - Delivery of slurry is not allowed, or the pump may break in a short period of time.
 - For the operation with adhesive liquid, take the following measures for the prevention of a stuck plunger:
 - a. In operation, flush out the pump head with clean water or cleaning liquid via the flushing ports.
 - b. Before the pump is left unused, take apart the pump head and clean with the water or the liquid. Use of tap water for flushing is not allowed.
 - Use care handling the pump. Do not drop. An impact may affect pump performance.
 - Rotating parts of this pump are protected by SUS frame covers. Do not remove that protections.
 - Observe the allowable liquid temperature range of 5-40°C (41-104°F).
 - A small amount of fluid can flow back to the suction line as the plunger stops rotating in the cylinder. To prevent the back flow, balance the discharge and suction line pressure to the same or use a solenoid/check valve that runs in sync with the pump.
 - Commissioning is required in order to expel air from tubing before full operation.
- You can change the head angle from the default position. Use the head shifter to adjust the head angle and measure the actual liquid volume per shot until the best volume is obtained (calibration). You will see the head angle index on the front frame absolutely for your reference. Always stop the pump (stop the power supply to the motor) and then change the angle.
 - Solution in the discharge line may be under pressure. Release the pressure from the discharge line before disconnecting plumbing or disassembly of the pump to avoid solution spray.
 - Wear protective clothing when handling or working with pumps. Consult solution SDS for appropriate precautions. Do not come into contact with residual solution.
 - A slight amount of leakage may occur from the plunger lip sealing depending on liquid characteristics.
 - Do not allow foreign matters to enter the pump. Clogging may cause the plunger to be locked or damaged.
 - Do not clean the pump or nameplate with a solvent such as benzine or thinner. This may discolour the pump or erase printing. Use a dry or damp cloth or a neutral detergent.
 - Always stop the pump with the plunger extended to the full, so the cylinder will not retain liquid in it.
 - Use of a flammable/harmful/corrosive chemical liquid can harm you in the form of a slight leak from the plunger lip sealing or a relief valve on the discharge line. Provide a drain line in your system so you can drain/collect such a liquid safely at any time during operation or stop.

Overview

An Iwaki Hicera pump is a metering pump with fine ceramic wet ends such as a plunger, a cylinder and other related parts.

The plunger reciprocates and rotates in the cylinder where liquid is taken in from a suction line and then let out to a discharge line.

Principle of operation

In the suction process, the rotating plunger contracts to take in liquid into the cylinder from a suction line as the duct on the plunger passes the inlet.

In the discharge process, the rotating plunger extends to let out liquid from the cylinder to a discharge line as the duct on the plunger passes the outlet.

Contraction process

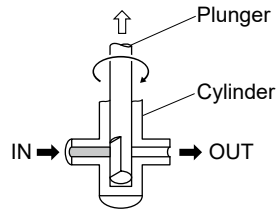

Expansion process

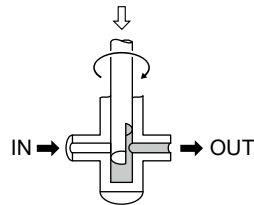

- ⇕ : Plunger reciprocation
- ↻ : Plunger rotation
- ➔ : Flow direction

Part Names

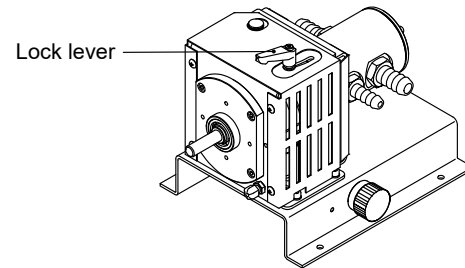
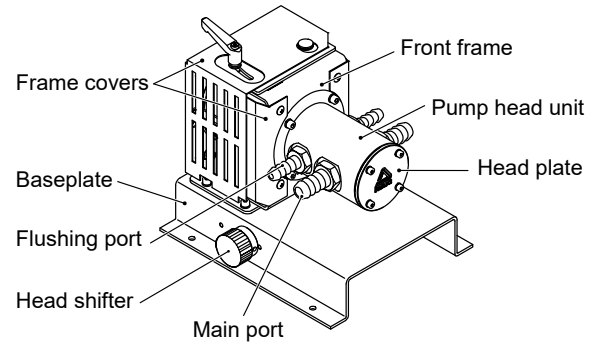

Identification Codes

The model codes represent the following information.

V - 25 A S P 7 - N
a b c d e f g

a. Series name

V: Hicera pump

b. Plunger diameter

25: $\varnothing 25$ mm

c. Plunger/Cylinder

A: Al_2O_3/Al_2O_3

d. Wet end materials

S: SUS304 (machined)

e. Flushing port

P: Pumps with flushing ports

f. Main port

7: 19mm O.D. tube fitting

8: Rc $\frac{1}{2}$ " I.D. female adapter

9: 16mm O.D. \times 13mm I.D. union fitting

g. Motor (Purchase separately)

N: coupling connection

Installation

Installation of the pump, tubing and wiring are described in this section.

! Points to be observed

Do not place explosive or flammable material near the pump.

Pump Mounting

1 Select a suitable place

Select the best installation location. See the "Precautions for Use" section as well. Also, install the pump as close to the supply tank as possible.

*Observe the maximum suction lift of 2 meters/6.56 feet (with clean water). Note it varies with liquid characteristics.

*A slight amount of leakage may occur from the plunger lip sealing depending on liquid characteristics. Take measures to protect the motor or any other peripheral devices from getting wet with a possible leak.

2 Mount the pump horizontally

Make sure the pump is installed level on the baseplate.

*Use care handling the pump. Do not drop.

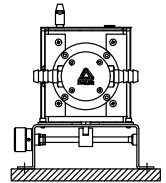

3 Anchor the baseplate with the M6 bolts

Be sure to fix at four points.

4 Connect the pump and motor

Select the best possible installation location. Ensure the pump shaft and the motor shaft are connected properly, too.

(See a manual of your coupling to align them properly. The example listed below details the alignment with a jaw coupling.)

Use a straight edge or a square onto the hubs at two points with a 90° interval and make sure the hubs/shafts are aligned in line.

Poor alignment* could lead to abnormal noise or vibration and damage to the pump.

*A coupling is limited in the shaft misalignment that they can accommodate. See the specifications of the coupling that you select for the maximum allowable misalignment. It is not manufacturer's responsibility for any failure resulting from the coupling you select.

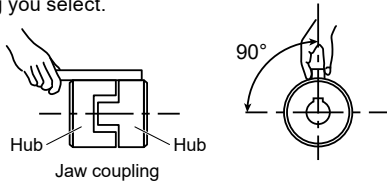

Select a stepper motor that meets the following three requirements.

No.	Item	Motor speed	Torque
1	Recommended pull-out torque	0-300min ⁻¹	5.3 N·m or more
2	Maximum pull-out torque		7.6 N·m
3	Recommended pull-in torque	0-100min ⁻¹	6.1 N·m or more

*If selecting any DC or AC motor other than the stepper motor to this pump, see the requirement 1 and 2 for your operating torque and the 3 for the starting torque. It is not manufacturer's responsibility for any failure resulting from the motor you select.

5 Install a coupling cover before operating a pump for your safety

A spinning coupling can catch your hands or clothes. Purchase a coupling cover separately. (A coupling cover is not provided.)

Plumbing

Observe the following points for plumbing.

- Have tubing length shortest with the minimum number of bends in order to reduce pipe resistance.
- The suction line of the pump and the discharge line should be completely sealed for the prevention of air ingress into a flow line. An imperfect suction line connection especially entrains air and reduces performance.
- Purchase separately a proper tube that matches the main port (the 19mm O.D. tube fitting or the 16mm O.D. × 13mm I.D. union fitting) or an additional male fitting (to the Rc½" female adapter). The flushing ports as well (14mm O.D. tube fitting, 8mm O.D. × 6mm I.D. union fitting, or Rc¾" I.D. female adapter). Such a tube should be pressure-/corrosion-resistant to specified operating conditions.
- The P15 and P11 O rings build up a face seal coupling between each port and the pump head unit. Do NOT use thread seal tape to the main port threads and the flushing port threads which may adversely affect the face sealing.
- Install a shutoff valve in the suction line when the pump is installed in a flooded suction system.

NOTE

Make sure the main port and the flushing port won't loosen from the pump head unit in operation. If necessary, tighten them by 5N·m so the face sealing is surely maintained.

Main port

■ 19mm O.D. tube fitting (V-25ASP7-N)

- 1 Use a tube that matches the tube fitting and push it as far as it will go so it won't or take in air
- 2 Use a band to secure tubes onto the flushing ports so that it won't come off when pressurized or externally stressed

■ Rc $\frac{1}{2}$ " I.D. female adapter (V-25ASP8-N)

- 1 Use thread seal tape to an additional male fitting (purchase separately) so the connection is sealed effectively
- 2 Use an M18 wrench to hold the Rc $\frac{1}{2}$ " I.D. female adapter and a proper tool to tighten the additional male fitting by 5N·m

■ 16mm O.D. × 13mm I.D. union fitting (V-25ASP9-N)

- 1 Use a tube that matches the union fitting and push it as far as it will go so it won't come off or take in air
- 2 Hold the tube and use an M16 wrench to tighten the union nut by 5N·m

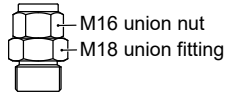

Flushing port

Delivery of some chemicals over the main port, which "deposit" in the form of silica or so in between the cylinder and the plunger, may catch the plunger. Build up a cleaning liquid circulation system over the flushing port (CIP) that will help the plunger continue to rotate free (except such liquids are too sticky or too settling.).

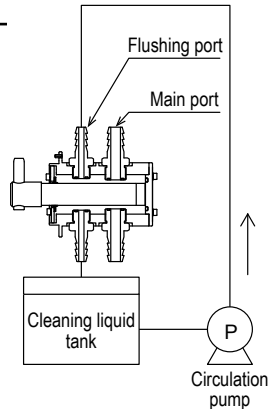

NOTE

Keep the flushing ports tubed. Use a chemical resistant tubing or piping. Free flushing ports can result in a chemical leak and also accelerate deposition (a locked plunger) as air is taken to dry up chemicals earlier.

■ 14mm O.D. tube fitting (V-25ASP7-N) or 8mm O.D. × 6mm I.D. union fitting (V-25ASP9-N)

1 Build up and run the cleaning liquid circulation system

Use a clean water or a cleaning liquid that won't chemically react with the main liquid flow.

NOTE

- Select the optimal pump size and tank size.
- Renew the cleaning liquid to keep the good cleaning efficiency.
- Keep the cleaning liquid pressure lower than the main liquid pressure so it won't be taken into the main liquid line.

*When the main liquid won't deposit and there is no chance for a locked plunger, it's not necessary to build up the cleaning liquid circulation system; however, have the flushing ports terminated or looped so a chemical won't leak. Having said this, the looped tubing could be pressurized over time. Use measures to release the pressure before removing tubing to avoid solution spray.

■ Rc $\frac{3}{8}$ " I.D. female adapter (V-25ASP8-N)

1 Have the flushing ports terminated with a Rc $\frac{3}{8}$ " O.D. male plug to eliminate the risk of a chemical leak

Use a chemical resistant plug. Use thread seal tape so the connection is sealed effectively.

Wiring

Supply power to a motor/sensor and properly ground the pump.

! Points to be observed

Electrical work should be performed by a qualified electrician. Always observe applicable codes or regulations.

Motor wiring

See the specifications of the motor that you select.

Sensor wiring

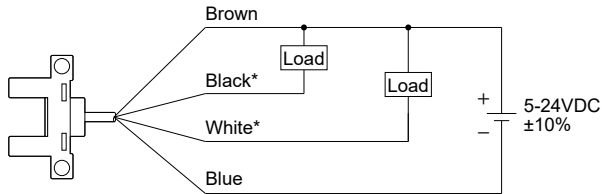

*Electrically insulate the black and white lines if not used.

	Wire color	Type
OUT 1	Black	Light-ON
OUT 2	White	Dark-ON

■ Sensing routine

The sensor monitors the CW motor rotation with the sensing sequence as shown below.

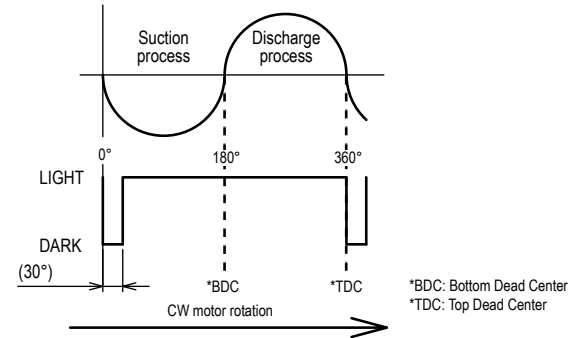

Operation

! Points to be observed

- Do not close a discharge valve or a suction valve in operation.
- Do not run pump dry for more than 3 minutes.

Starting the pump

1 Check if plumbing and wiring are done correctly

2 Check if the power supply voltage is correct

3 Fully open both suction and discharge valves

4 Prime and run the pump for testing

Check if a flow direction is correct.
(Turn the pump head angle in the range of 0-20° to discharge liquid.)

*In a clockwise rotation (seen from the pump head), liquid flows in the direction of "a".

*In a counter clockwise rotation (seen from the pump head), liquid flows in the direction of "b".

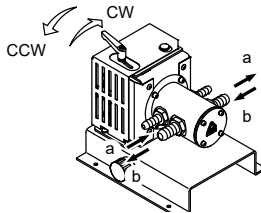

5 Check liquid flows without a hitch

If you notice any abnormality, turn off power and investigate/ solve root causes. Refer to the Troubleshooting section on page 12.

6 Turn off the pump, release the lock lever, and use the head shifter to extend the pump head angle to 20°

7 Run the pump and an open-ended discharge line (zero pressure) until gas is removed from the pump and tubing

This process is important especially when the pump is first used in plumbing.

8 Adjust the pump head angle to the best position

Adjust the pump head angle in the range of 0° (zero flow) to 20° (max flow). Fasten the lock lever afterwards.

*Do not try to turn the head shifter exceeding the 0° to 20° range.

NOTE

Use measures so the pump won't take in debris, or you will see a stuck plunger or pump failure.

Stoppage

1 Flush out the pump head with clean water via the main and the flushing ports (CIP) every time a sticky or settling liquid is delivered

Take apart and then clean the pump head manually (COP) as needed.

2 Before a long period (one week or more) of stoppage, take apart and clean the pump head (COP)

Supportive operation

Perform inching for the plunger to rotate free.

Inching (with a reversible motor)

Delivery of some chemicals, which “deposit” in the form of silica or so in between the cylinder and the plunger, may catch the plunger. Rotate the motor one revolution clockwise and then counter-clockwise (inching) every hour while your system is left stopped so such chemicals won’t deposit and the plunger won’t be stuck.

*The thinner chemical, the less chance for deposition.

Recovery run (with a stepper motor)

In case the stepping motor has stepped out, stop sending the pulse signal from a user PLC and then just restart the motor in the start/stop region.

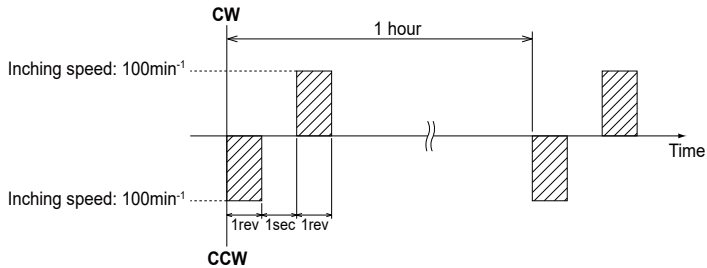

Maintenance

Troubleshooting, inspection, wear part replacement, exploded views and specifications are described in this section.

! Important

Follow instructions in this manual for replacement of wear parts. Do not disassemble the pump beyond the extent of the instructions.

Troubleshooting

First check the following points. If the following measures do not help remove problems, contact us or your nearest distributor.

Problem	Possible Cause	Corrective Action
The pump does not start to run.	Power is not supplied.	• Supply power.
	Wrong wiring or disconnection	• Correct wiring.
	Plunger lock due to deposition*	• Take apart the pump head and clean wet ends.
	Clogging by debris.	• Remove debris. Replace parts if damaged.
	Discharge pressure is too high.	• Reduce discharge pressure.
	A suction or a discharge line is closed during operation.	• Open both the suction and discharge lines.
The pump does not deliver liquid during operation.	Wrong wiring or disconnection	• Correct wiring.
	High specific gravity or high viscosity	• Use an applicable pump model.
	Pump runs dry.	• Stop the pump and check the plunger and cylinder for damage. Renew them if needed.
	A suction or a discharge line is closed during operation.	• Open both the suction and discharge lines.
	Crushed suction line	• Use a pressure resistant tubing.
	A supply tank is empty.	• Replenish the supply tank.
	The motor is rotating the other way around.	• Correct the rotational direction with a user controller or PLC.

The flow rate is too small.	Air ingress through a tube joint	• Keep tube joints air-tight.
	Development of cavitation	• Build up a flooded suction system. • Reduce a motor rpm, liquid temperature, and tubing resistance.
Significant vibration or noise.	Pump rotation speed is too low. A lip seal is crushed or not there.	• Increase a rotation speed. • Replace as necessary.
	Pump runs dry.	• Stop the pump and check the plunger and cylinder for damage. Renew them if needed.
	Clogging by debris.	• Remove debris. Replace parts if damaged.
	Discharge pressure is too high.	• Reduce discharge pressure.
	A suction or a discharge line is closed during operation.	• Open both the suction and discharge lines.
	Air ingress through a tube joint	• Keep tube joints air-tight.
	Development of cavitation	• Build up a flooded suction system. • Reduce a motor rpm, liquid temperature, and tubing resistance.
	A supply tank is empty.*	• Replenish the supply tank.
	Anchor bolts are loose.*	• Fasten anchor bolts.
	Sympathetic vibration with the pump and other parts of system	• Fit vibration isolators to base-plate. • Reduce the pump speed.
Liquid leaks.	Poor shaft alignment	• Align the pump and motor shafts as close as possible.
	Discharge pressure is too high.	• Reduce discharge pressure.
	A suction or a discharge line is closed during operation. A lip seal is crushed or not there.	• Open both the suction and discharge lines. • Replace as necessary.
Pump stops unintentionally.	Wrong wiring or disconnection	• Correct wiring.
	Plunger lock due to deposition	• Take apart the pump head and clean wet ends.
	High specific gravity or high viscosity	• Use an applicable pump model.
	Clogging by debris.	• Remove debris. Replace parts if damaged.
	Discharge pressure is too high.	• Reduce discharge pressure.
	A suction or a discharge line is closed during operation.	• Open both the suction and discharge lines.

The asterisked causes are often the case with this pump.

Inspection

Perform daily inspection to keep pump performance and safety.

Daily inspection

Check the following points. If you notice any abnormal or dangerous conditions, suspend operation immediately and inspect/solve problems according to the Troubleshooting section.

When wear parts come to the end of life, replace them with new ones. Contact us or your nearest distributor for detail.

No.	States	Points to be checked	How to check
1	Pumping	• If liquid is pumped.	Flow meter or visual inspection
		• If a discharge and a suction pressure is normal.	Pressure gauge
2	Noise and Vibration	<ul style="list-style-type: none"> • If abnormal noise or vibration occurs. They may be a sign of abnormal operation. • If a friction noise occurs from between the spherical bearing and the plunger pin. It's a sign of less lubrication. Apply a molybdenum disulfide grease to the plunger pin at regular intervals to keep them lubricated. See the next page as well. 	Visual or audio inspection
3	Air ingress from pump head joints and a suction line	<ul style="list-style-type: none"> • If there is evidence of leakage. Find and tighten a leak point as necessary. • If the pump takes in entrained air. Check the joints/line for loose connection and tighten as necessary. 	Visual inspection

Greasing (plunger pin)

The plunger pin slides in the spherical bearing of the pump during operation. It is necessary the sliding area is always lubricated with molybdenum disulfide grease. Make sure it is greased well at every six month or every time the pump head is taken apart (except harsh operating condition).

■ Greasing the plunger pin

- 1 Take apart the pump head and take out the plunger**
 See page 15 or later before taking apart the pump head.
- 2 Use molybdenum disulfide grease to the sliding area of the plunger pin**
 The Dow Corning Toray MOLYKOTE® BR2 PLUS is used in our factory.

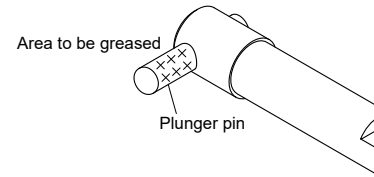





Wear Part Replacement

To run the pump for a long period, wear parts need to be replaced periodically. It is recommended that the following parts are always stocked for immediate replacement. Contact us or your nearest distributor for detail.

⚠ Precautions

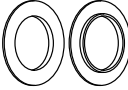
- Solution in the discharge line may be under pressure. Release the pressure from the discharge line before disconnecting plumbing or disassembly of the pump to avoid solution spray.
- Rinse wet ends thoroughly with clean water.
- Renew the O ring and the lip seals every time the pump head is taken apart.

Wear part list

Part names	Lip seal (10)	P31 O ring (5)	P15 O ring (6)	P11 O ring (8)
				
Design life	2000hr	Every time the pump head is taken apart.		
# of parts	2	1	2	2

*Wear part duration varies with the pressure, temperature and characteristics of liquid.

*The design life is based on the continuous operation with clean water at ambient temperature.

Exploded view

See this exploded view when taking apart/putting together the pump. Do not disassemble the pump beyond the extent of instructions in this manual.

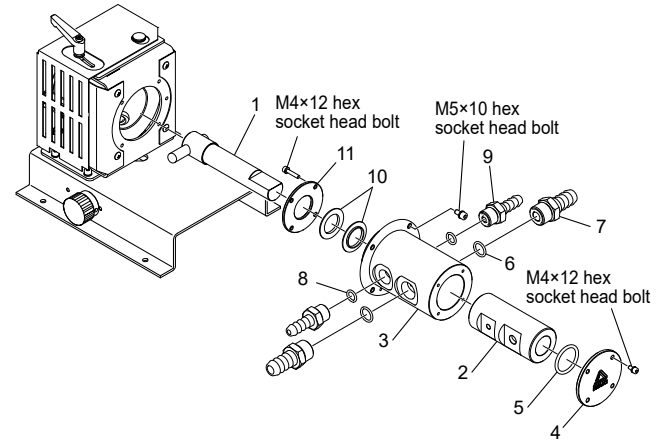

No.	Part names	Q'ty	Materials
1	Plunger unit	1	Al ₂ O ₃
2	Cylinder	1	Al ₂ O ₃
3	Pump head unit	1	SUS304
4	Head plate	1	SUS316
5	P31 O ring	1	FEPM
6	P15 O ring	2	FEPM
7	Main port	2	SUS316
8	P11 O ring	2	FEPM
9	Flushing port	2	SUS316
10	Lip seal	2	PTFE
11	Rear plate	1	SUS316

Disassembly & Assembly

■ Before service is performed

- 1 Use the flushing ports to clean the wet ends
- 2 Drain/empty the pump head unit and the discharge line
- 3 Turn off power and stop the pump
- 4 Close the suction line

■ Disassembly

- 1 Remove tube connections from the pump head unit (3)

NOTE

Solution in the discharge line may be under pressure. Release the pressure from the discharge line before disconnecting plumbing or disassembly of the pump to avoid solution spray.

- 2 Adjust the pump head angle

Release the lock lever and use the head shifter to adjust the angle to the 20° position (the full stroke length).

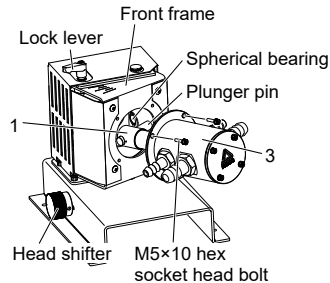

- 3 Remove the four M5×10 hex socket head bolts

- 4 Detach the whole pump head unit (3) by decoupling the plunger unit (1) from the spherical bearing

- 5 Unscrew the main ports (7) and the flushing ports (9) from the pump head unit (3)

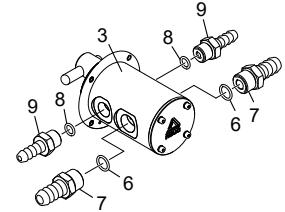

- 6 Remove the P15 O rings (6) from the main ports (7) and the P11 O rings (8) from the flushing ports (9)

- 7 Remove the four M4×12 hex socket head bolts and the rear plate (11) to separate the plunger unit (1) from the cylinder (2). Rotate and pull out the plunger unit.

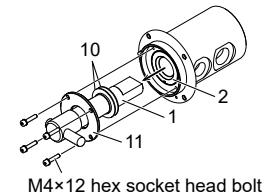

8 Slip the lip seals (10) out of the plunger unit (1) slowly

NOTE

- Be careful not to damage lip seals.
- Clean all parts thoroughly after disassembly.
- Use care handling the plunger unit and cylinder. Do not drop. An impact may damage these ceramic parts.

9 Remove the four M4×12 hex socket head bolts and the head plate (4) from the pump head unit (3)

Hold the pump head unit upright (with the head plate top of it) so the cylinder (2) won't drop off inadvertently.

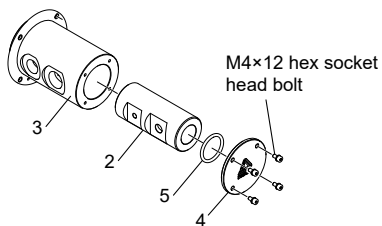

10 Remove the P31 O ring (5) from the head plate back

11 Remove the cylinder (2) from the pump head unit (3) slowly

■ Assembly

1 Slide the cylinder (2) into the pump head unit (3) slowly

*The cylinder and the pump head unit have the mating point. The mating guide will help the cylinder slide in a correct way.



2 Attach the P31 O ring (5) to the head plate (4) and tighten four M4×12 hex socket head bolts by 2.0N·m

Check that the mating point exists on the right of the pump head unit (3) as shown below.

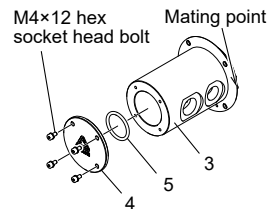

3 Slide the lip seals (10) onto the plunger over the rear plate (11)

Softly fit the lip seals onto the plunger unit from the duct end. The optional tool will assist this process. Remove the tool afterwards.

NOTE

- Be careful not to damage lip seals.
- Use benzine or thinner to clean plunger thoroughly after the lip seals are slid on it.

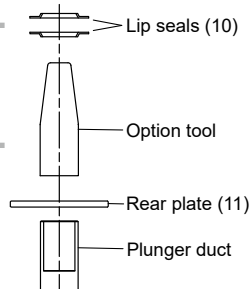

4 Turn and pass the plunger unit (1) slowly through the cylinder (2)

Hold the plunger pin. Keep the plunger straight to the cylinder.

NOTE

Do not pass the plunger unit in friction with the cylinder. It would be stuck.

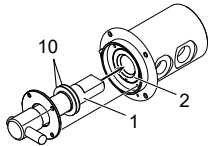

5 Fit the P15 O rings (6) into the groove of the main ports (7) and the P11 O rings (8) into the flushing ports (9)

*These O rings are different in size. Use proper O ring to the proper port.

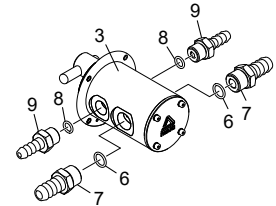

6 Hand tighten the main ports (7) and the flushing ports (9) to the pump head unit (3)

Do not tighten too much at this point.

7 Tighten the four M4×12 hex socket head bolts and the rear plate (11) by 2.0N•m

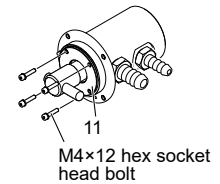

8 Relax the hand tightness of the main ports (7) and the flushing ports (9) and the O rings

so as to have O rings free from stress and distortion.

9 Use an M18 spanner to tighten the main ports by 5N•m and M16 spanner to the flushing ports as well (5N•m also)

10 Connect the plunger and the spherical bearing over the plunger pin

- *Adjust the direction of the spherical bearing hole if necessary.
- *The plunger pin and the bearing hole slide each other. Use molybdenum disulfide grease to the whole sliding area of the plunger pin. See page 13 as well.

11 Use the Shin-Etsu Chemical KF-96-20CS silicone oil to the plunger unit surface (10mm plunger pin end)

Pull out the plunger unit 10mm from the cylinder beforehand.

12 Move the plunger unit back and forth for about 10 reciprocation in the cylinder to give a lubricating property to between the plunger and the lip seals

13 Tighten the four M5×10 hex socket head bolts by 2.8N·m and the pump head unit (3) to the front frame

Use the mating point to position the pump head unit correctly.

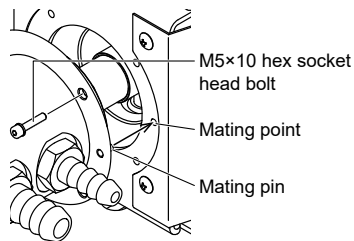

Specifications/Outer Dimensions

Specifications

Information in this section is subject to change without notice.

■ Pump unit

Max flow volume per shot	Max flow volume per min (RV)	Max speed	Max pressure	Weight
11mL/shot	3300mL/min	300min ⁻¹	0.2MPa	15kg

*The above information is based on pumping clean water at the full stroke length, ambient temperature and zero discharge pressure.

*The max flow volume per shot were collected at 100min⁻¹ with a discharge line open to the atmosphere.

*Allowable room temperature: 0-40°C (32-104°F)

*Allowable liquid temperature: 5-40°C (41-104°F)

*Allowable ambient humidity: 35-85%RH (non-condensing)

*The maximum allowable suction lift: 2m with clean water (can change with liquid characteristics)

*Flush the pump head with clean water or solvent after operation with the crystallizing or adhesive liquid.

■ Sensor





Power voltage Vcc	Output open-circuit voltage Vo	Output inflow current Isink
5-24VDC	Vcc	50mA

Outer dimensions

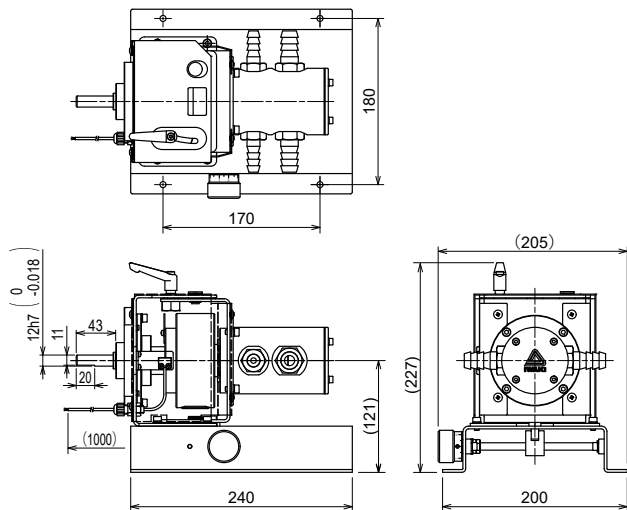
Sizes are shown in mm.

■ V-25ASP7-N (19mm O.D. main port/14mm O.D. flushing port)



	Main port	Flushing port
V-25ASP8-N	 Rc $\frac{1}{2}$ " I.D. female adapter	 Rc $\frac{3}{8}$ " I.D. female adapter
V-25ASP9-N	 16mm O.D. × 13mm I.D. union fitting	 8mm O.D. × 6mm I.D. union fitting

EC DECLARATION OF CONFORMITY

A copy of the original Declaration of Conformity

(SUPPLIER'S NAME)

WE
IWAKI CO.,LTD.

(ADDRESS)

6-6 2-CHOME KANDA-SUDACHO CHIYODA-KU TOKYO JAPAN

(PRODUCT)

DECLARE UNDER OUR SOLE RESPONSIBILITY THAT THE PRODUCTS
HICERA PUMP

(MODEL NAME)

V SERIES

TO WHICH THIS DECLARATION RELATES ARE IN CONFORMITY WITH THE
FOLLOWING STANDARDS OR DIRECTIVES AS FAR AS APPLICABLE

(DIRECTIVES)

MACHINERY DIRECTIVE 2006/42/EC (ANNEX IIA)
RoHS DIRECTIVE 2011/65/EU

(STANDARDS)

EN ISO12100: 2010 EN 809: 1998 + A1: 2009 EN IEC63000: 2018

(A PERSON WHO IS AUTHORISED TO COMPILE THE TECHNICAL FILE IN THE
COMMUNITY)

IWAKI EUROPE GMBH
SIEMENSRING 115 D-47877 WILLICH GERMANY

NOTE: THIS DECLARATION BECOMES INVALID IF TECHNICAL OR OPERATIONAL
MODIFICATIONS ARE INTRODUCED WITHOUT THE MANUFACTURER'S
CONSENT.

J. Sawada

Tokyo, September 13, 2021

TSUTOMU SAWADA
DEPUTY SENIOR GENERAL MANAGER,
QUALITY ASSURANCE HEAD OFFICE

(PLACE AND DATE OF ISSUE)

(NAME AND SIGNATURE OR EQUIVALENT MARKING OF AUTHORIZED PERSON)

DOCUMENT NO. IS-51K-522-3



<https://www.iwakipumps.jp>

IWAKI CO.,LTD. 6-6 Kanda-Sudacho 2-chome Chiyoda-ku Tokyo 101-8558 Japan
TEL: +81 3 3254 2935 FAX: +81 3 3252 8892

European Headquarter / IWAKI Europe GmbH
TEL: +49 2154 9254 0 FAX: +49 2154 9254 48

Germany / IWAKI Europe GmbH
TEL: +49 2154 9254 50 FAX: +49 2154 9254 55

The Netherlands / IWAKI Europe GmbH (Netherlands Branch)
TEL: +31 74 2420011 FAX: +49 2154 9254 48

Italy / IWAKI Europe GmbH (Italy Branch)
TEL: +39 0445 561219 FAX: +39 0445 569088

Spain / IWAKI Europe GmbH (Spain Branch)
TEL/FAX: +34 934 741 638

Poland / IWAKI Europe GmbH (East Europe Branch)
TEL: +48 12 347 0755 FAX: +48 12 347 0900

Belgium / IWAKI Belgium N.V.
TEL: +32 13 670200 FAX: +32 13 672030

Denmark / IWAKI Nordic A/S
TEL: +45 48 242345

Finland / IWAKI Suomi Oy
TEL: +358 10 201 0490

France / IWAKI France S.A.
TEL: +33 1 69 63 33 70 FAX: +33 1 64 49 92 73

Norway / IWAKI Norge AS
TEL: +47 23 38 49 00

Sweden / IWAKI Sverige AB
TEL: +46 8 511 72900

U.S.A. / IWAKI America Inc.
TEL: +1 508 429 1440 FAX: +1 508 429 1386

Argentina / IWAKI America Inc. (Argentina Branch)
TEL: +54 911 6477 4116

Brazil / IWAKI Do Brasil Comercio De Bombas Hidraulicas LTDA.
TEL/FAX: +55 19 3244 5900

Singapore / IWAKI Singapore Pte Ltd.
TEL: +65 6316 2028 FAX: +65 6316 3221

Indonesia / IWAKI Singapore (Indonesia Office)
TEL: +62 21 6906606 FAX: +62 21 6906612

Malaysia / IWAKIm SDN. BHD.
TEL: +60 3 7803 8807 FAX: +60 3 7803 4800

Australia / IWAKI Pumps Australia Pty Ltd.
TEL: +61 2 9899 2411 FAX: +61 2 9899 2421

China (Hong Kong) / IWAKI Pumps Co., Ltd.
TEL: +852 2607 1168 FAX: +852 2607 1000

China (Guangzhou) / GFTZ IWAKI Engineering & Trading Co., Ltd.
TEL: +86 20 84350603 FAX: +86 20 84359181

China (Shanghai) / IWAKI Pumps (Shanghai) Co., Ltd.
TEL: +86 21 6272 7502 FAX: +86 21 6272 6929

Korea / IWAKI Korea Co., Ltd.
TEL: +82 2 2630 4800 FAX: +82 2 2630 4801

Taiwan / IWAKI Pumps Taiwan Co., Ltd.
TEL: +886 2 8227 6900 FAX: +886 2 8227 6818

Thailand / IWAKI (Thailand) Co., Ltd.
TEL: +66 2 322 2471 FAX: +66 2 322 2477