



Magnetic Drive Pumps Product Guide



The Heart of Industry

An Overview of IWAKI's World Leading Magnetic Drive Pumps

Magnetic drive technology is fast becoming the pump choice for corrosive applications.

IWAKI offers a wide range of magnetic drive pumps from fractional horsepower

for OEM applications to large pumps for chemical processing.

No other manufacturer can offer such a wide breadth of technology.

This brochure is an overview of IWAKI's large chemical process pumps.

For information on our smaller pump technology
please contact IWAKI or visit <https://www.iwakipumps.jp/en/>



CONTENTS

Fluoroplastic (ETFE/CFRETFE/PFA)

Magnetic Drive Pumps (MDM, MXM, SMX-F, MX-F) -----Page **3**
 Large Magnetic Drive Pumps (MDW, MDE) -----Page **5**
 Performance Comparison -----Page **7**
 Materials -----Page **8**

Liquid end Materials: ETFE/CFRETFE/PFA

Page **9**

MDW series



Liquid end Materials: ETFE/CFRETFE/PFA

Page **11**

MDE series



Liquid end Materials: CFRETFE/PFA

Page **13**

MDM series



Liquid end Material: CFRETFE

Page **15**

MXM series



Liquid end Material: CFRETFE

Page **17**

SMX-F series



Liquid end Material: CFRETFE

Page **19**

MX-F series



Polypropylene (CFRPP/GFRPP)

Performance Comparison -----Page **23**
 Materials -----Page **24**

Liquid end Material: CFRPP

Page **25**

AMP series



Liquid end Material: GFRPP

Page **27**

SMX series



Liquid end Material: GFRPP

Page **29**

MX series



Installation Precautions -----Page **32**
 Magnetic Drive Pumps use -----Page **33**
 Optional Accessories -----Page **34**

Magnetic Drive Pumps

(MDM, MXM, SMX-F, MX-F)

Unique Design Prevents Dry Running Non Contact System

High powered rare earth magnets prevent the magnet capsule from coming in contact with the rear casing, thus preventing heat generation. This improves the dry running resistance and increases pump life in comparison to other fluororesin pumps.

(MDM50-2J / 65-2J has an integrated bearing and rear ring)

MDM



MDM

Bearing
Rear ring
Rear thrust

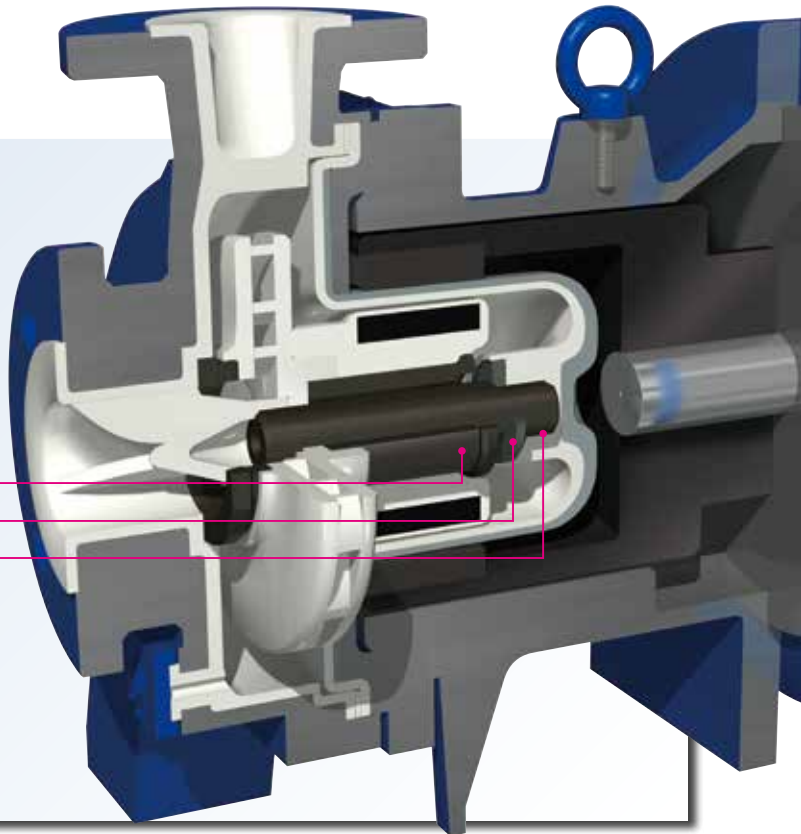

ETFE and PFA Available in Standard Models

Carbon fiber reinforced CFRETFE and PFA liners are available for varying applications. The unfilled PFA liners are ideal for high purity chemical applications.

MDM



MXM



Modular Design and Low Maintenance Cost

The pumps modular design leads to easy maintenance. There is no need to check clearances or align any liquid end parts. All wetted parts can be replaced individually reducing maintenance costs.

MDM

AMP

Highly Durable Structure

The ductile cast iron body of the pump provides strength and durability. The rear casing utilizes a secondary pressure containment cover made of fiber reinforced plastic. This allows for higher pressures as well as temperatures without the efficiency loss of eddy current generation. Should the drive magnet come in contact with the rear casing cover its non-metallic design will not generate sparks.

MDM

MXM

AMP

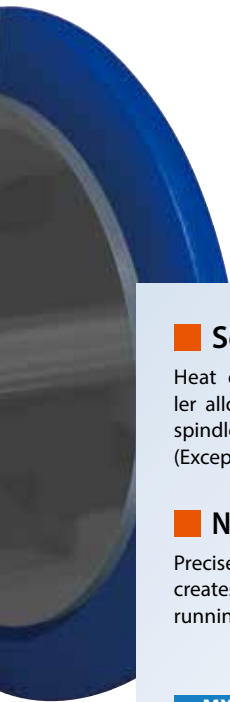

Self-Radiating Structure

Heat dispersion holes in the magnet capsule and impeller allow liquid circulation that cools the radial bearing and spindle. This design prevents melting due to excessive friction. (Except MX-F100)

Non-Contact Structure

Precise alignment of the drive magnet and magnet capsule creates a non-contact system that prevents friction during dry running.



SMX-F

Fast Self-Priming

The SMX-F requires no external self-priming chambers or valves. The gas-liquid separation design ensures fast self-priming of up to 4 meters in under 90 seconds.



Volute Casing Divided into Two Sections

The first non-metallic magnetic drive pump to incorporate a vortex chamber in the front and rear casings to increase pump efficiencies. (Except MX-F400)



MX-F

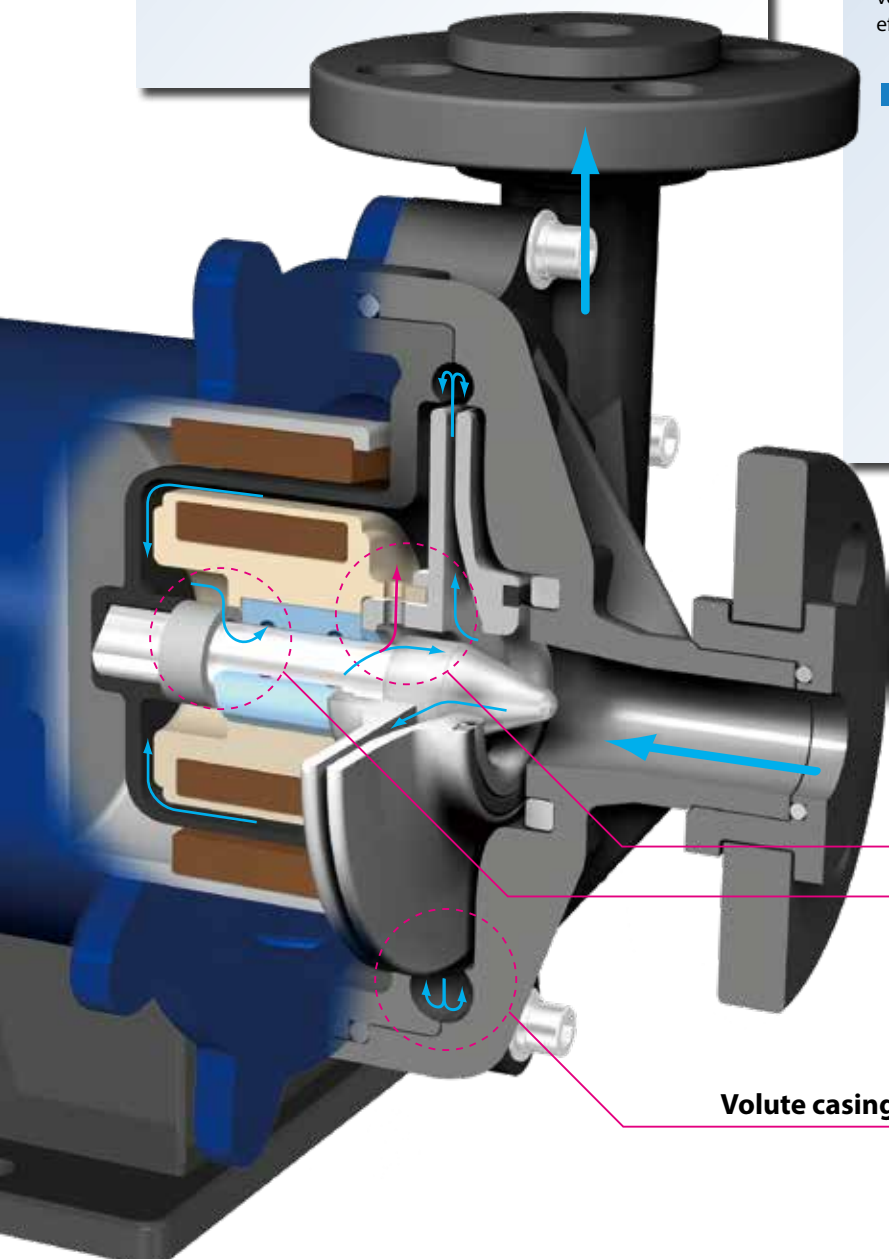

Self-radiating structure

Non-contact design

Volute casing divided into two sections

Large Magnetic Drive Pumps

(MDW, MDM)

The Large Class Fluoroplastic Magnetic Drive Pump

The MDW series are the large fluoroplastic magnetic drive pumps, offering high efficiency and durability for chemical process applications. Larger motors create higher outputs taking the MDW series into new high flow applications.

MDW

MDW-C (Foot mounted motor type)



MDW-F (Flange motor type)

Back Pullout System

The back pullout system allows easy maintenance and inspection without removing the pump from the piping. Integrated components and a sealed rear casing support structure allow motor removal without chemical leakage.

MDW

MDE

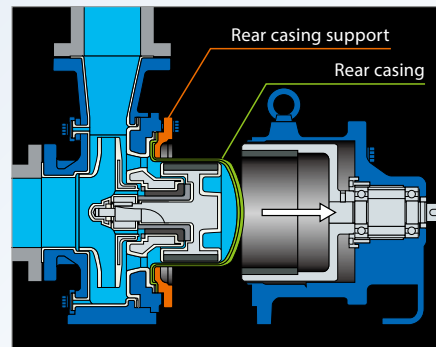

MDE

Compliant with ISO

The performance and dimensions standards of the pumps are in compliance with the international standard (ISO2858, 3661, 5199^{Note}). They are interchangeable with general-purpose centrifugal pumps.

Note: MDW is ISO2858, 3661 only
• Model MDE 125-250 is excluded

MDW

MDE

Robust Structure

The ductile cast iron body of the pump provides strength and durability. The rear casing utilizes a triple layer structure for high pressure resistance. A metal shaft is incorporated in the MDW & MDE design to withstand high radial forces and allow continuous operation even under difficult service conditions.

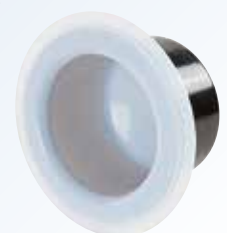

MDW

MDE

Liquid end
Materials

ETFE
CFRETFE
PFA

Performance Comparison for IWAKI Magnetic Drive Pumps

Materials: Fluoroplastic (ETFE/CFRETPE/PFA)

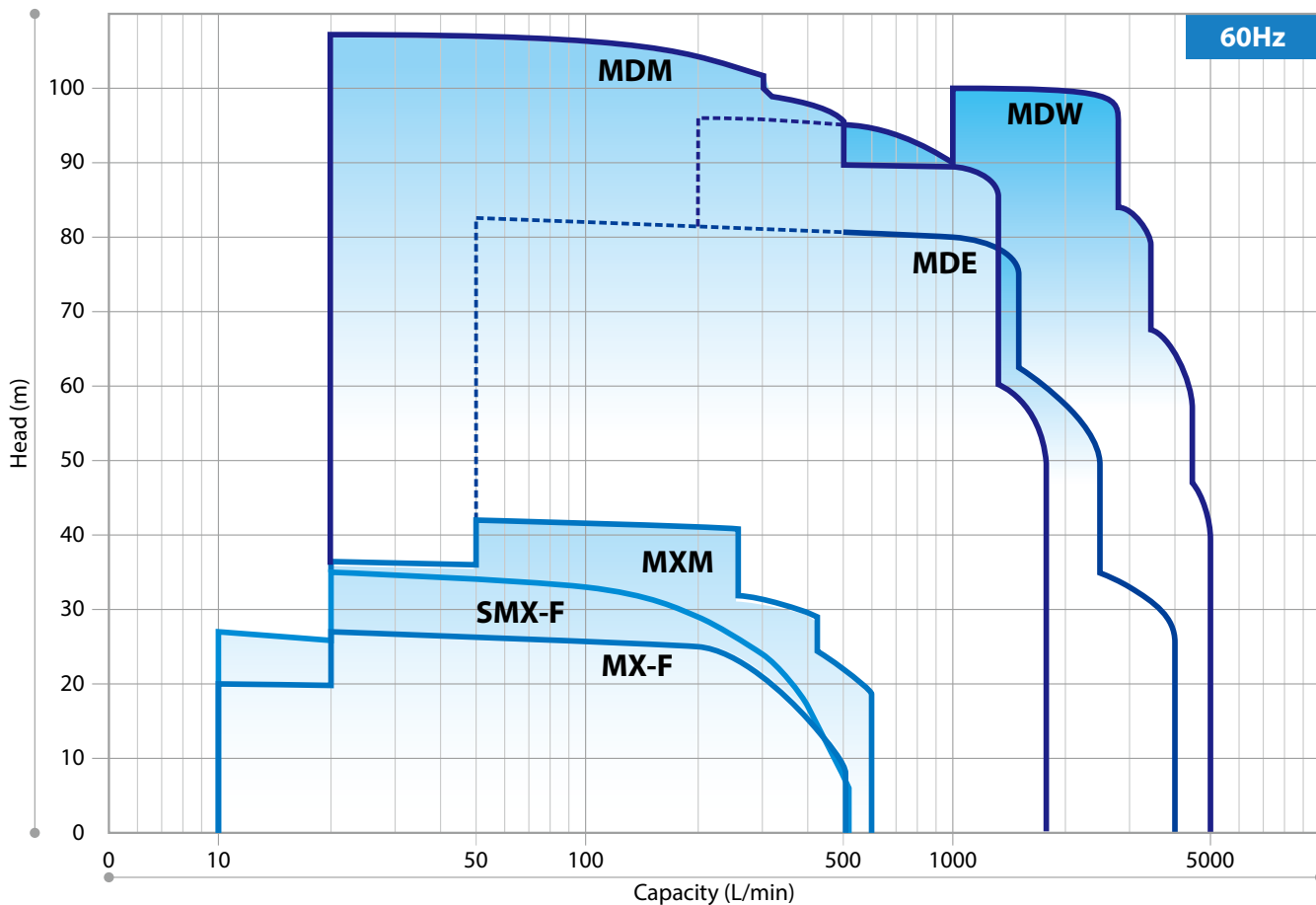
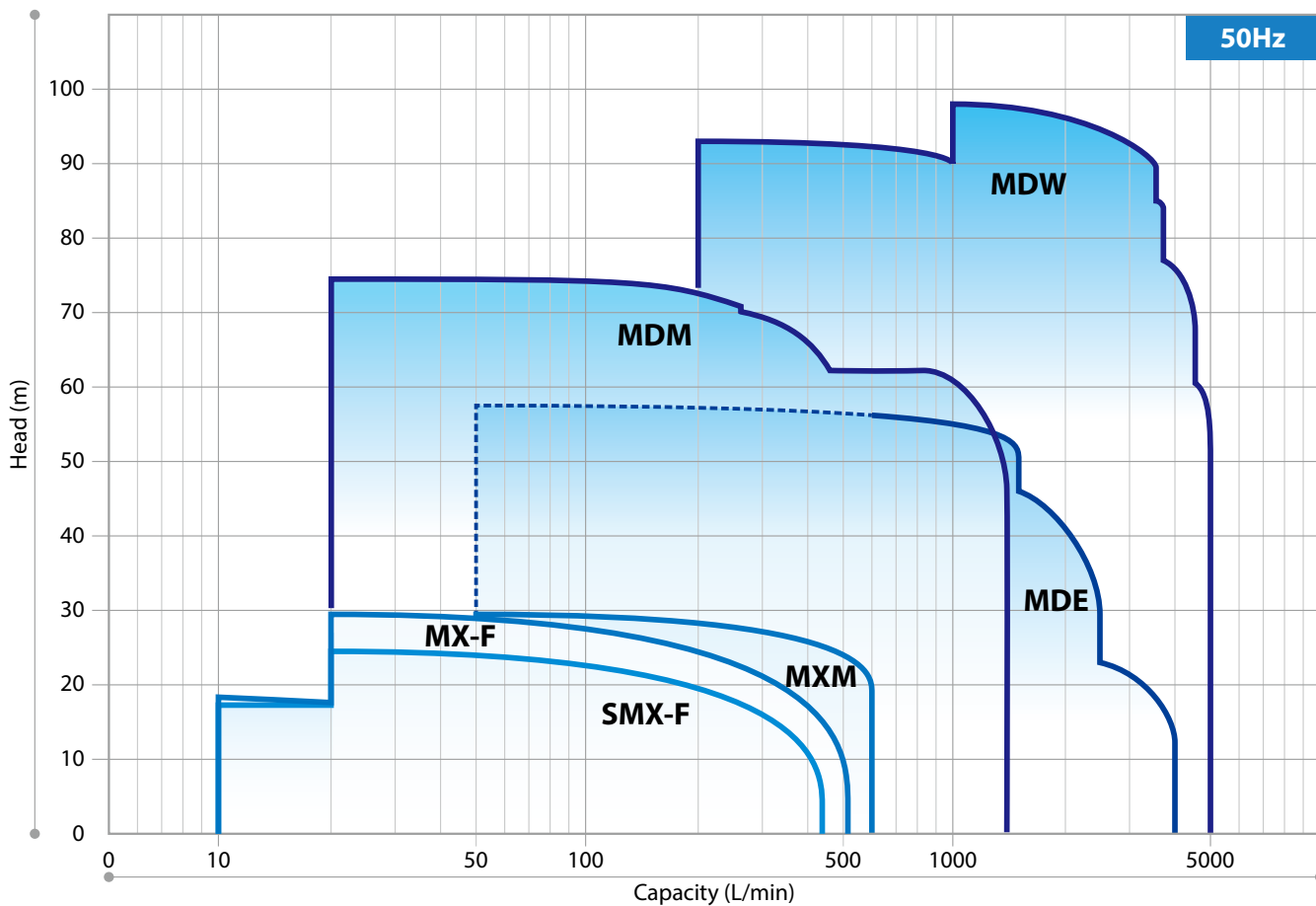

Liquid end Materials

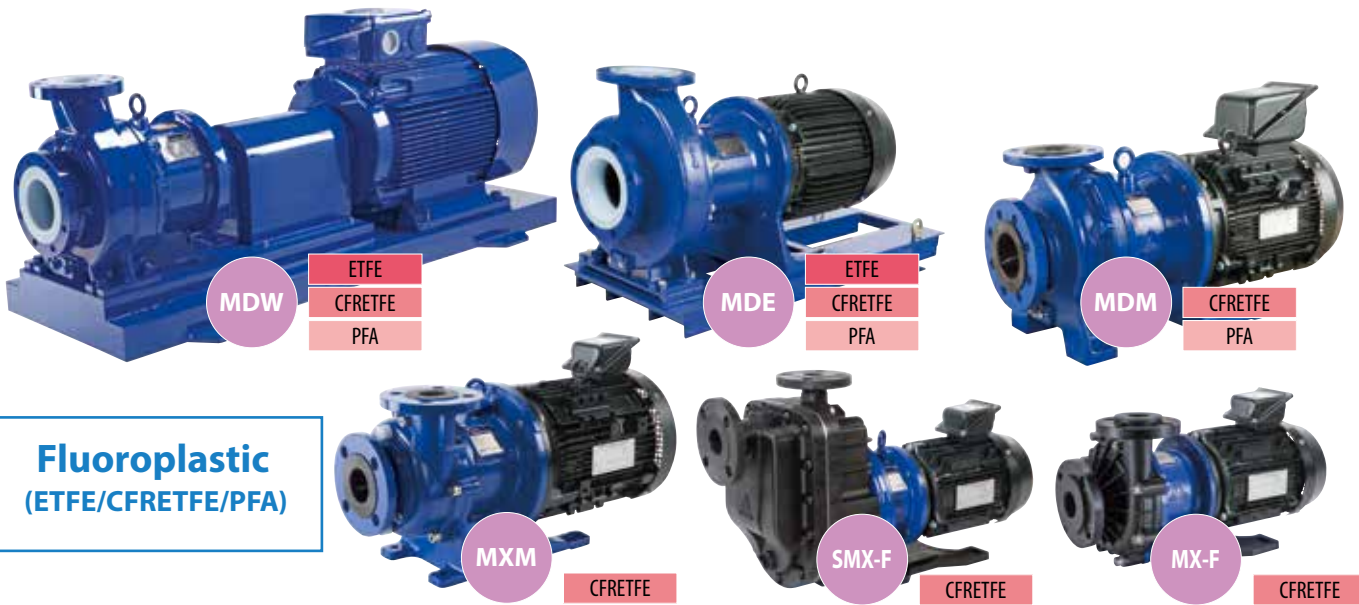

Materials

Model	Molded				Bearing system		Static sealing parts	
	Front casing	Rear casing	Impeller	Magnet capsule	Bearing	Spindle	Gasket	O ring
MDW	ETFE	PFA	CFRETFE	CFRETFE	SiC	—	PTFE	Kalrez®
	PFA		PFA	PFA				FKM
MDE	ETFE	PFA	CFRETFE	PFA	SiC	—	PTFE	EPDM
	CFRETFE		CFRETFE	CFRETFE				CFRETFE
MDM	PFA	PFA	PFA	PFA	SiC	SiC	PTFE	—
	CFRETFE	CFRETFE	CFRETFE	CFRETFE	High density carbon	High purity alumina ceramic		
High purity alumina ceramic					SiC	FFKM	FFKM	
SiC					SiC	FKM	FKM	
MXM	CFRETFE	CFRETFE	CFRETFE	CFRETFE	High density carbon	High purity alumina ceramic	FEPM	FEPM
					PTFE (with filler)			
					SiC	SiC	FKM	FKM
SMX-F	CFRETFE	CFRETFE	CFRETFE	CFRETFE	High density carbon	High purity alumina ceramic	FKM	FKM
					PTFE (with filler)			
					SiC	SiC	—	—
MX-F	CFRETFE	CFRETFE	CFRETFE	CFRETFE	High density carbon	High purity alumina ceramic	—	FKM
					PTFE (with filler)			
					SiC	SiC	—	—

Material Index

Plastic materials	
PFA	Tetrafluoroethylene/perfluoroalkoxy vinyl ether copolymer
ETFE	Ethylenetetrafluoroethylene copolymer ("Fluon®", "TEFZEL®" etc.)
CFRETFE	Carbon fiber-reinforced ETFE
PTFE	Polytetrafluoroethylene ("Teflon®" etc.)

Rubber	
FKM, FEPM	Fluorine rubber ("VITON®", "AFLAS®" etc.)
FFKM	Perfluoroelastomer ("Kalrez®" etc.)
EPDM	Ethylene propylene rubber

Materials for sliding parts/bearings	
High-density carbon	Hard carbon
High purity alumina ceramic	Alumina ceramic with a purity of 99.5% or more
SiC	Silicon carbide ceramic

Performance Curves

- Pump size (Suction×Discharge) MDW50: 80A×50A, MDW80: 125A×80A, MDW100: 125A×100A
- 2P: 2P poles motor, 4P: 4P poles motor

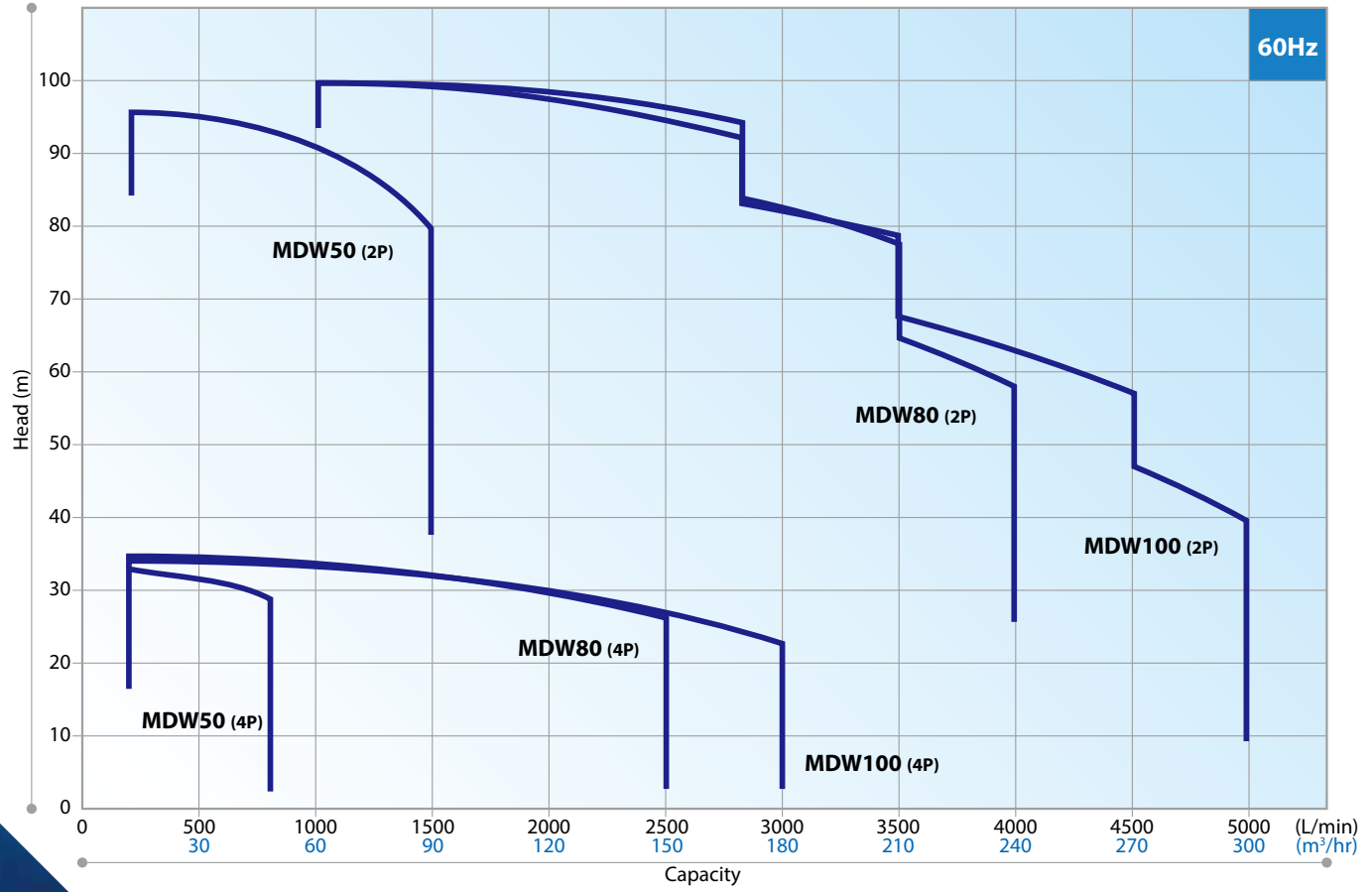
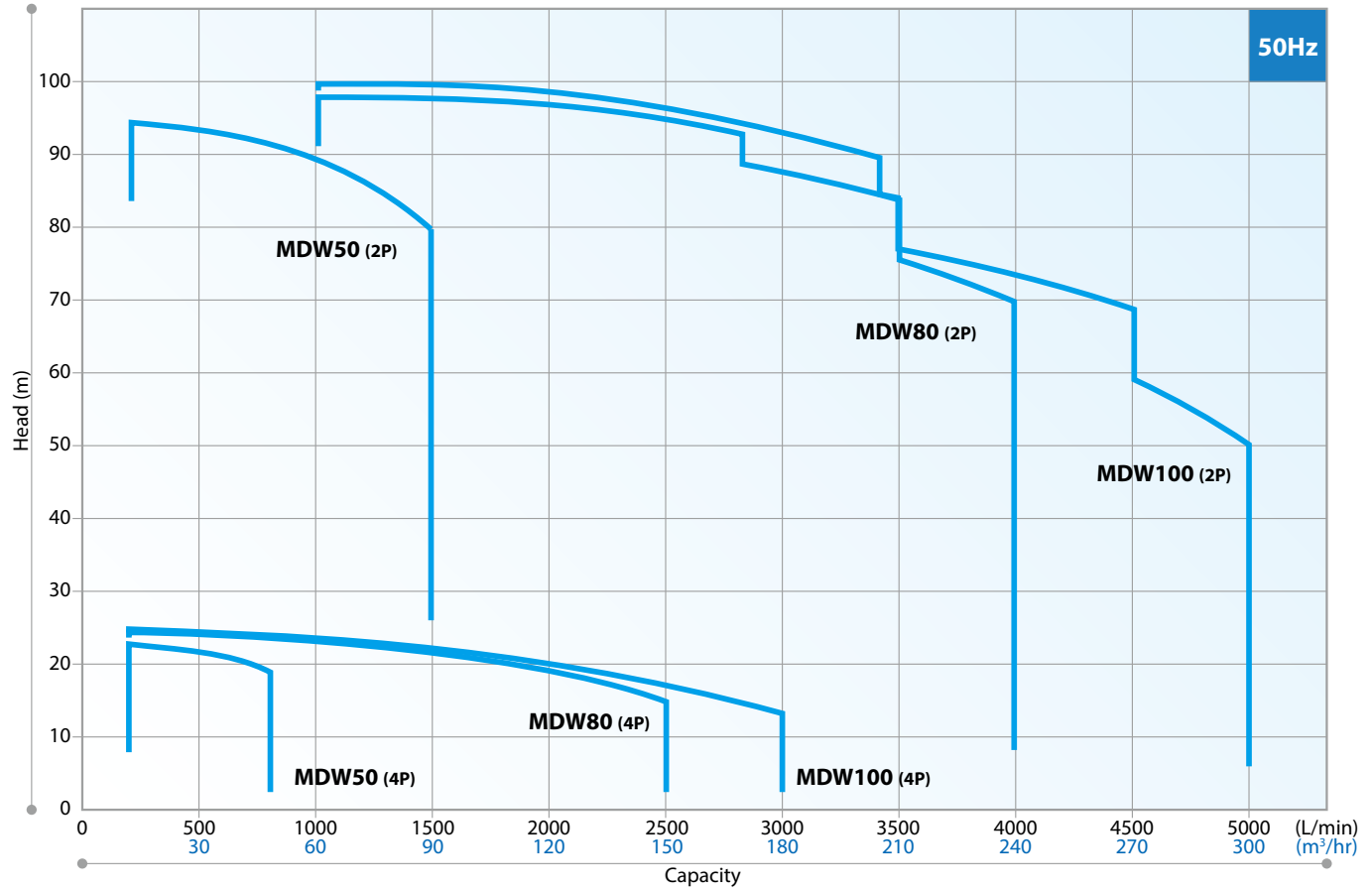

ETFE/CFRETFE/PFA
MDE



Liquid end Materials
ETFE/CFRETFE/PFA

MDE series

- Strong corrosion resistance
- High durability
- Compliant with ISO standards
- Back pullout design

Specifications (50/60Hz)

Max. discharge capacity.....240 m³/hr
Max. discharge head63.7/91.1 m
MaterialsETFE, CFRETFE, PFA
Power range11 to 45 (60Hz) kW
Pump size (Discharge).....65 to 125 A
Liquid temp. range.....0 to 100°C*

Specific-gravity limit3.0

(For details, please contact IWAKI.)

Sealing method.....Seal-less construction

*Fluid dependent.

Liquid end Materials

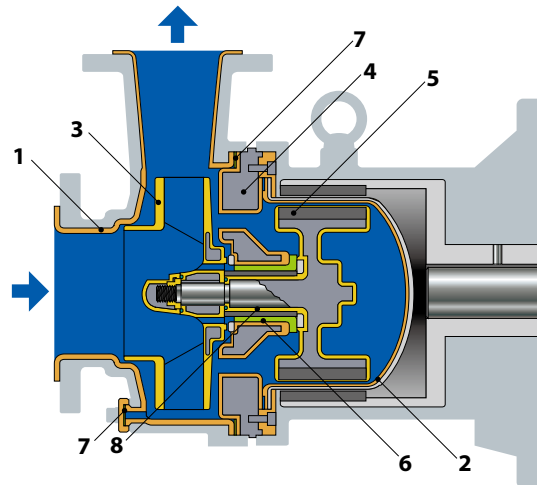

- 1 Front casing ETFE
- 2 Rear casing PFA
- 3 Impeller CFRETFE
- 4 Split plate..... PFA
- 5 Magnet capsule..... PFA
- 6 Bearing SiC
- 7 Gasket PTFE
- 8 O ring..... Kalrez®, FKM, EPDM

**The Large Class
Non-Metallic Magnetic Drive Pumps
for Chemical Processing**



Performance Curves

• Pump size (Suction×Discharge) MDE65: 80A×65A, MDE80: 100A×80A, MDE125: 150A×125A

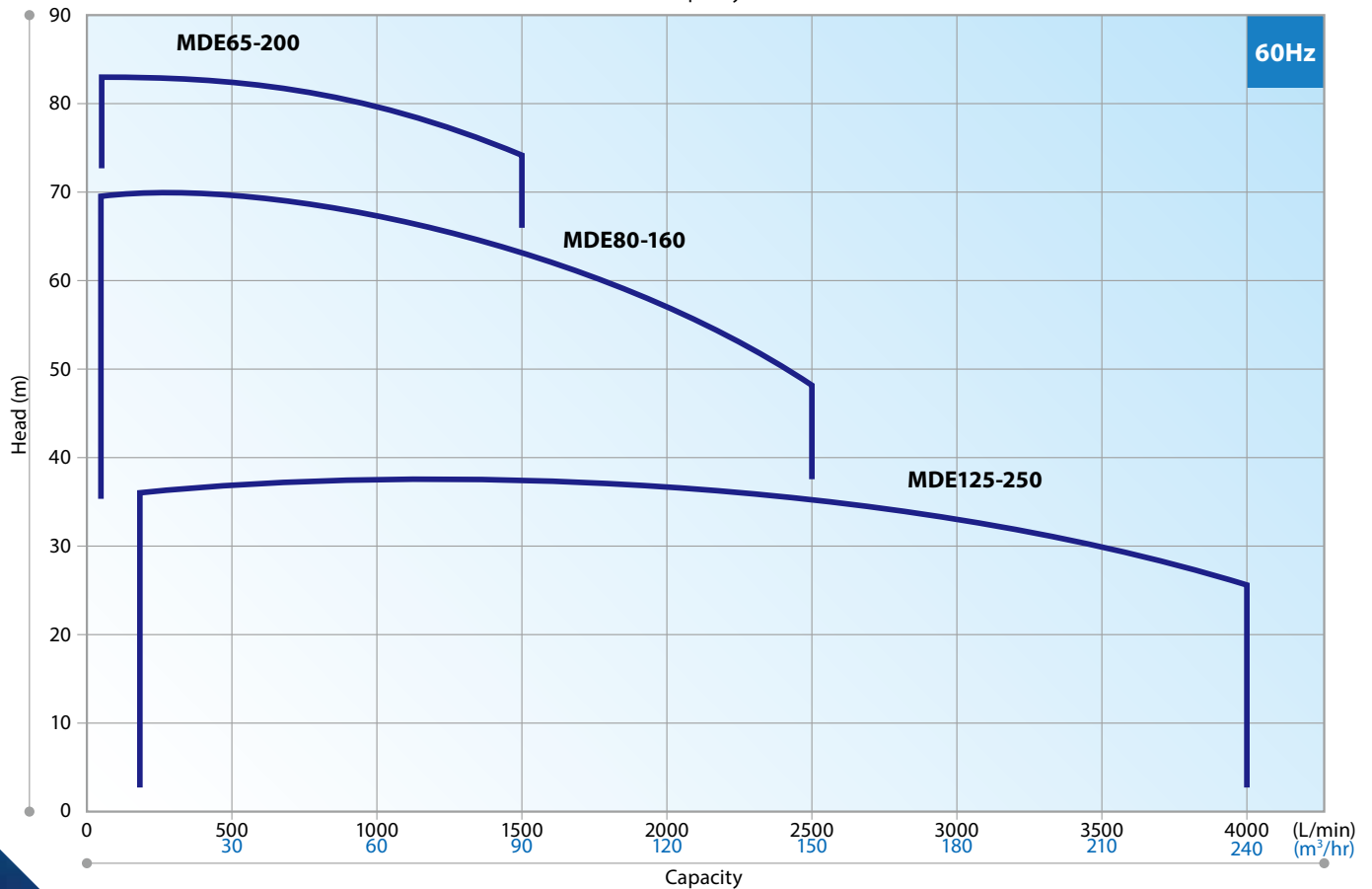
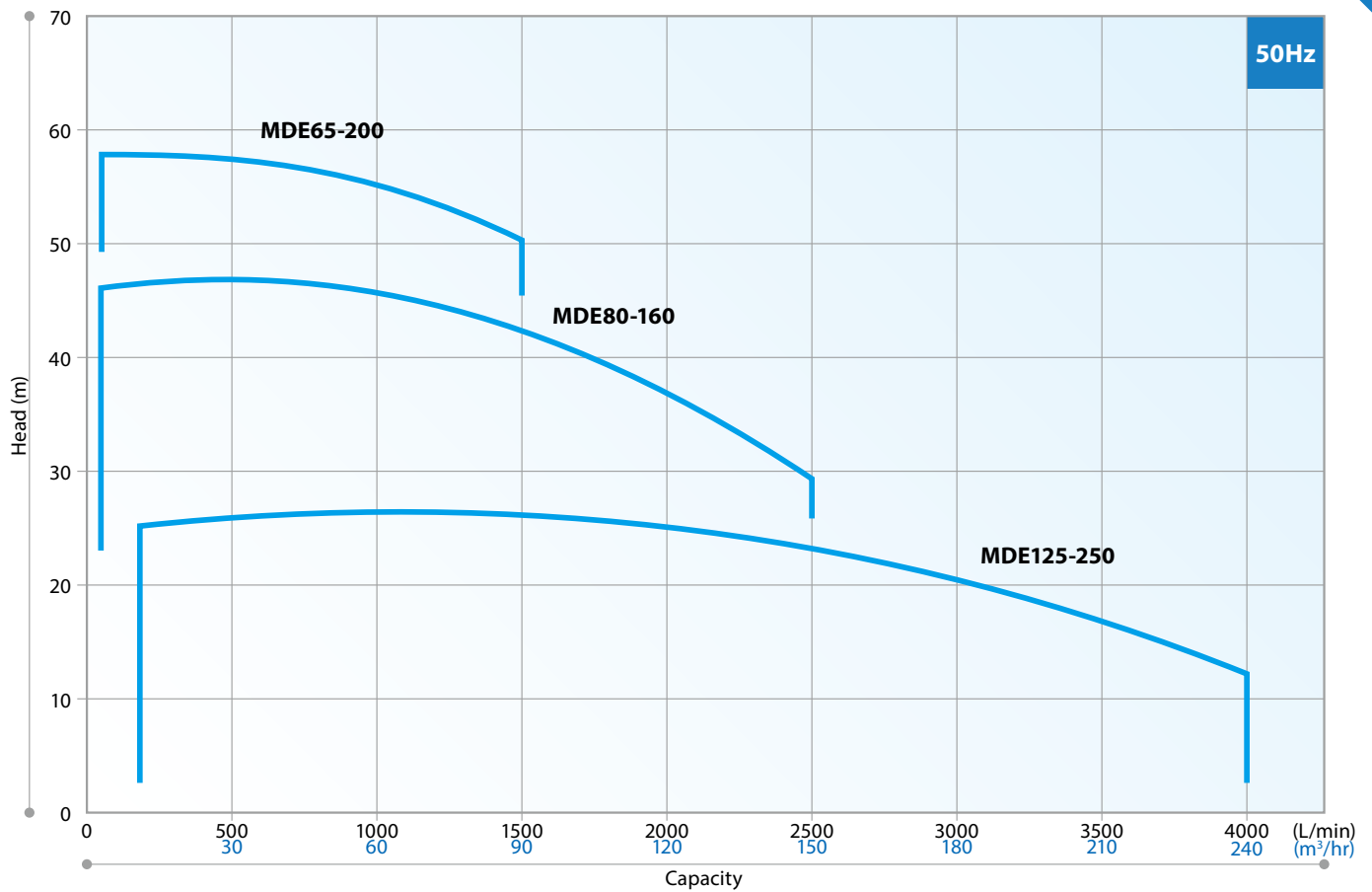

Performance Curves

- Pump size (Suction×Discharge) MDM25: 40A×25A, MDM40: 50A×40A, MDM50: 65A×50A, MDM65: 80A×65A
- 2P: 2P poles motor, 4P: 4P poles motor

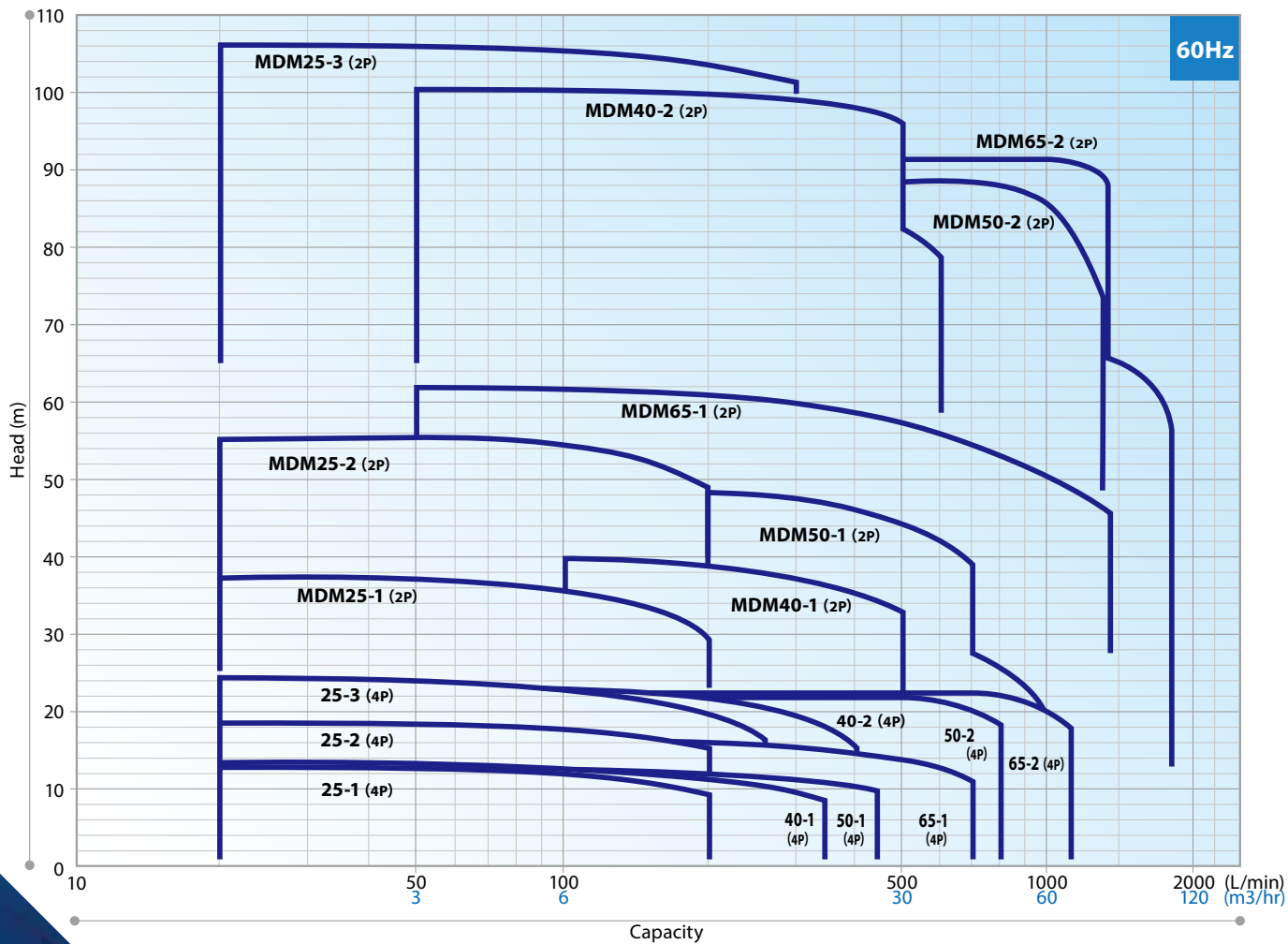
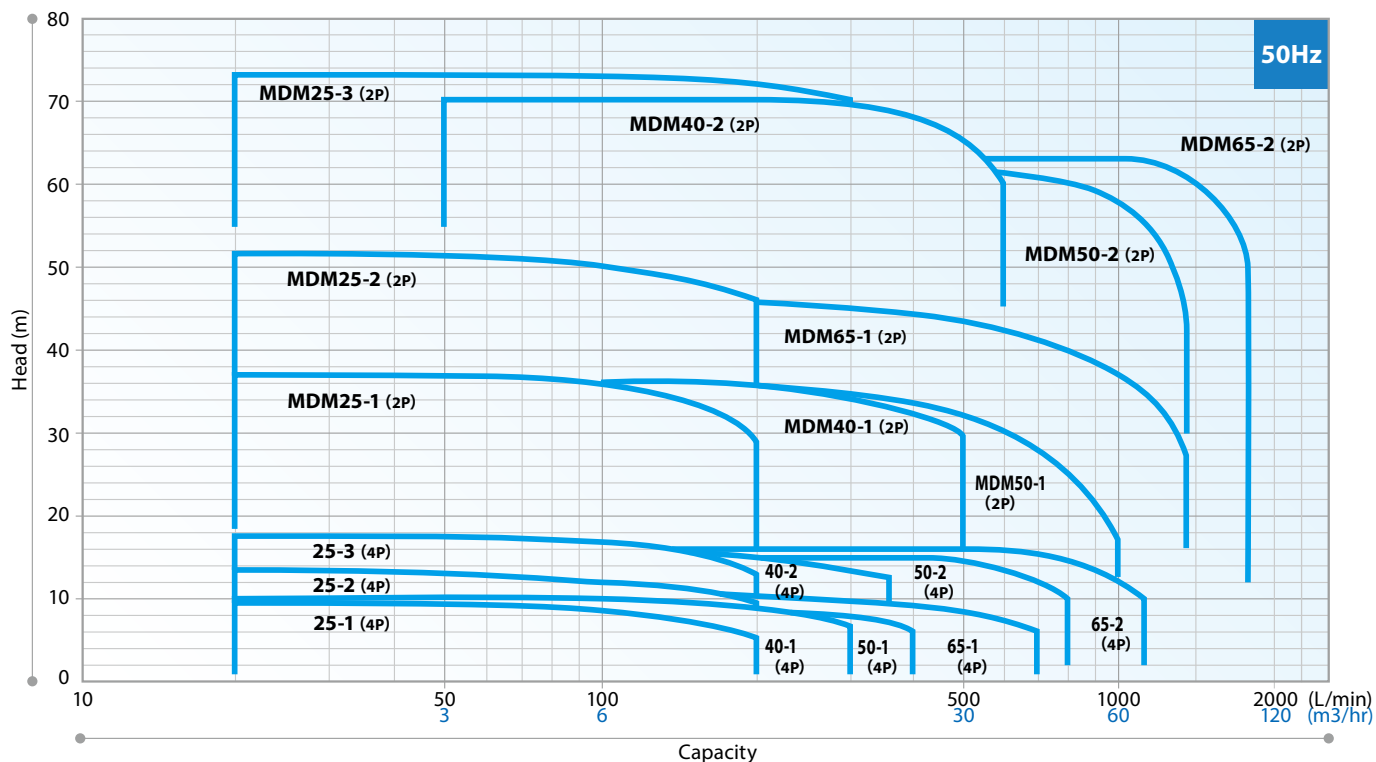



Liquid end Material
CFRETFE

MXM series

- Withstands difficult operation
- Superior corrosion resistance
- Robust structure
- Enhanced safety

Specifications (50/60Hz)

Max. discharge capacity.....600 L/min
 Max. discharge head29/42 m
 MaterialCFRETFE
 Power range0.4 to 3.7kW
 Pump size (Discharge).....25A, 40A
 Liquid temp. range*1-10 to 90°C*2
 Specific-gravity limit2.0

(For details, please contact IWAKI.)

Sealing method.....Seal-less construction

*1: Operating temperature for the pumps with an FEPM O-ring should be 10°C or more. Fluid dependent.

*2: -10 to 105°C for high temperature type

Liquid end Materials

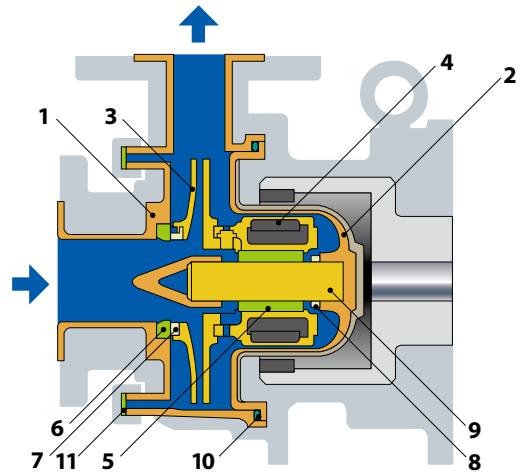

- 1 Front casing CFRETFE
- 2 Rear casing CFRETFE
- 3 Impeller CFRETFE
- 4 Magnet capsule CFRETFE
- 5 Bearing High density carbon,
High purity alumina ceramic, SiC
- 6 Liner ring High purity alumina ceramic, SiC
- 7 Mouth ring PTFE (with filler), SiC
- 8 Rear thrust CFRETFE
- 9 Spindle High purity alumina ceramic, SiC
- 10 O ring FKM, EPDM, FEPM, FFKM
- 11 Gasket FKM, EPDM, FEPM, FFKM

Magnetic Drive Pumps With an Excellent Balance of Features and Performance

Performance Curves

• Pump size (Suction×Discharge)

MXM22: 25A×25A, MXM44: 40A×40A, MXM54: 50A×40A

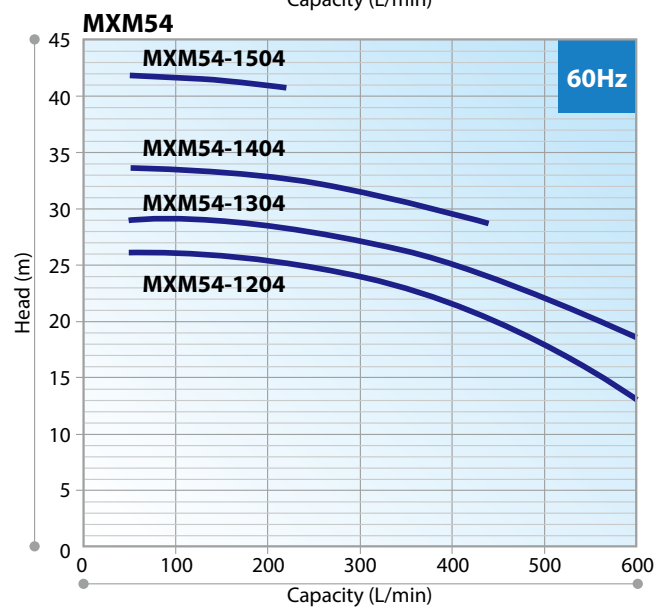
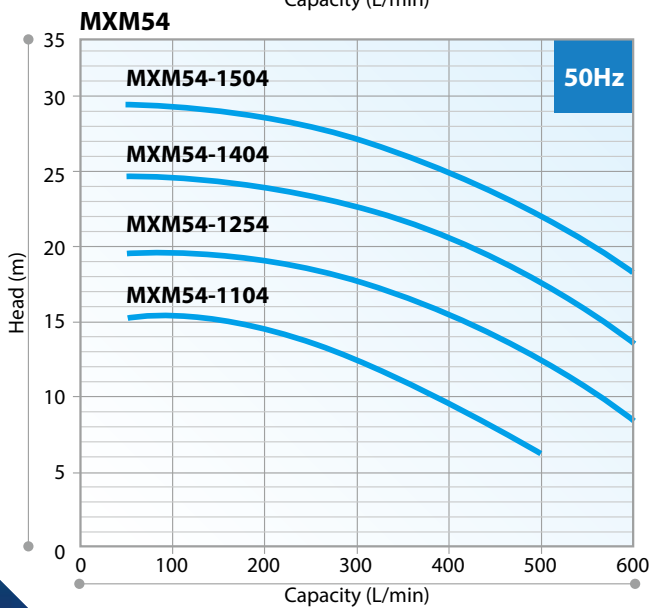
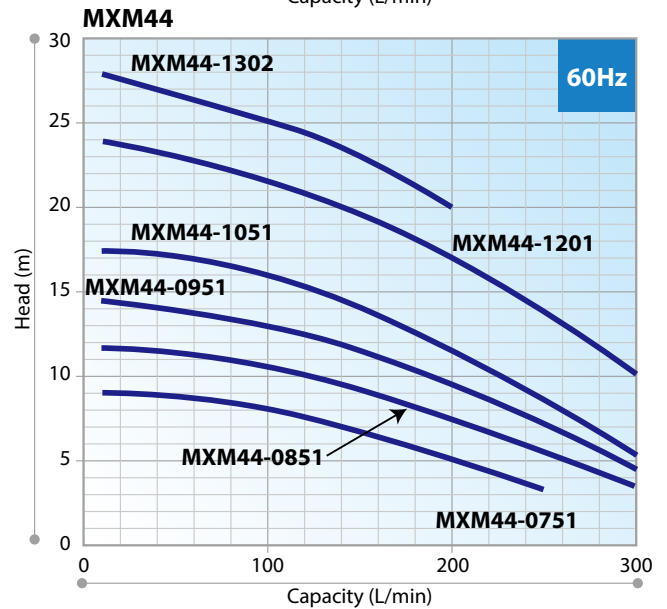
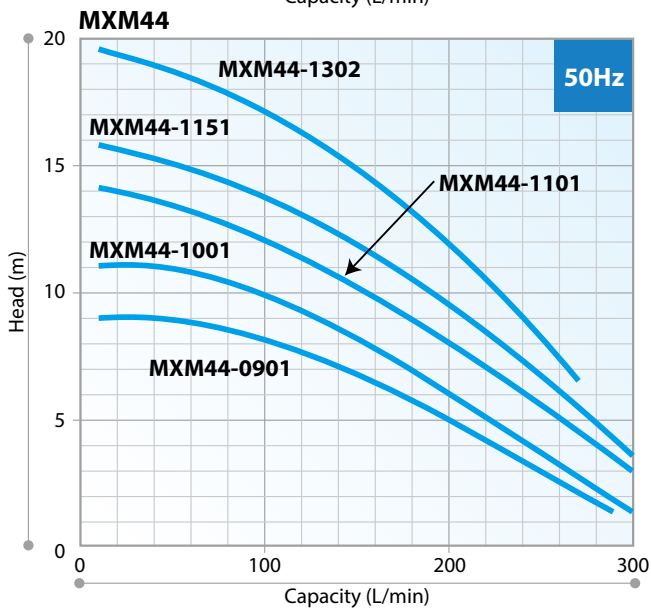
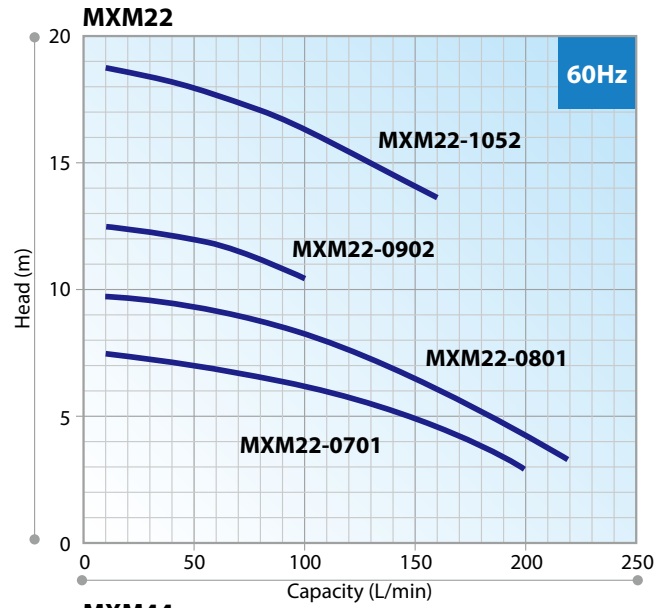
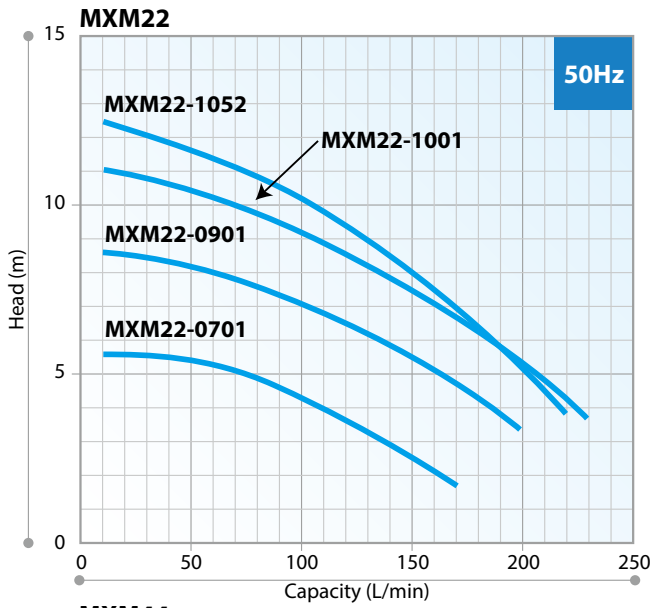

• High-lift/small-flow impellers are also available. Please contact us for more information.



Liquid end Material
CFRETFE

SMX-F series

- Excellent corrosion resistance
- Expanded versatility
- Easy maintenance
- Able to withstand abnormal operation
- Fast self-priming

Specifications (50/60Hz)

Max. discharge capacity.....440/520 L/min
 Max. discharge head24.5/35 m
 Rated self-priming height4m
 MaterialCFRETFE
 Power range0.4 to 3.7kW
 Pump size (Discharge).....25A, 40A
 Liquid temp. range.....0 to 80°C*
 Specific-gravity limit2.0
 (For details, please contact IWAKI.)
 Sealing method.....Seal-less construction
 *Fluid dependent.

Liquid end Materials

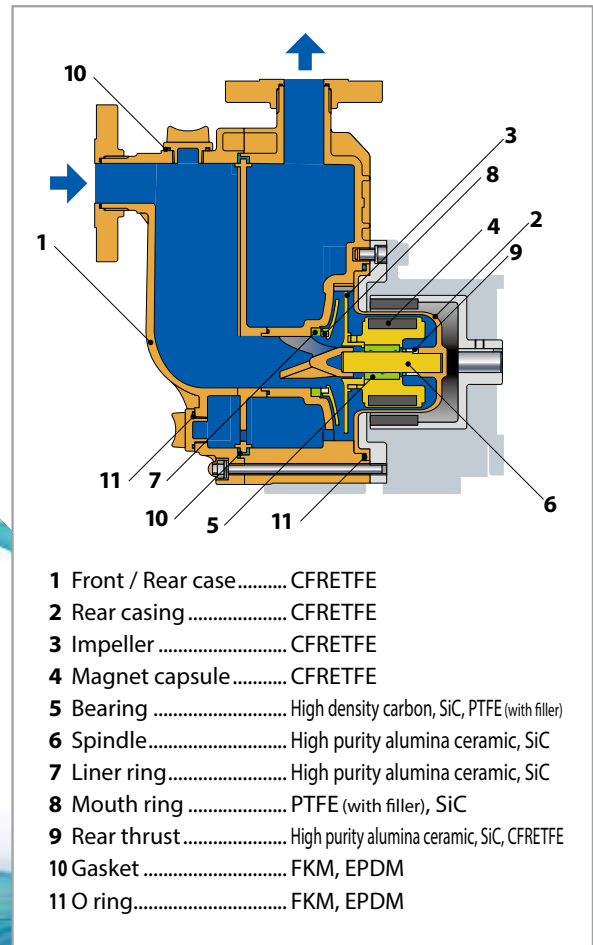

**Chemically Resistant Self-Priming
Magnetic Drive Pumps Built to
Withstand Abnormal Operation**

Performance Curves

• Pump size (Suction×Discharge)

SMX-F22: 25A×25A, SMX-F44: 40A×40A, SMX-F54: 50A×40A

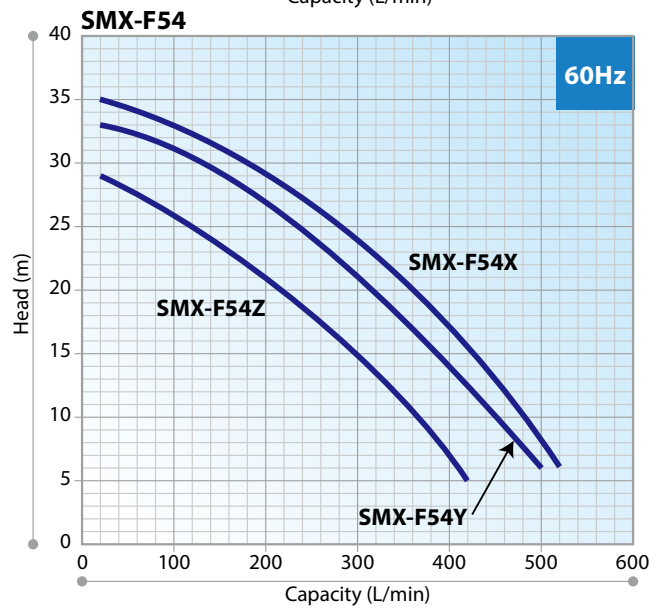
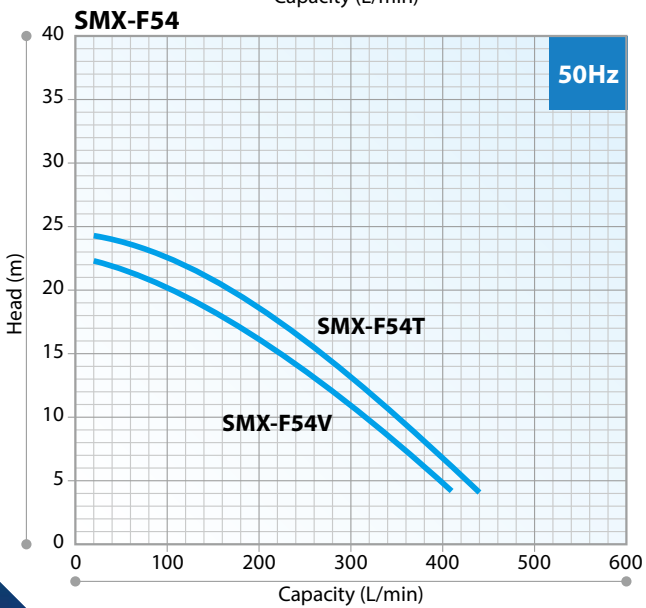
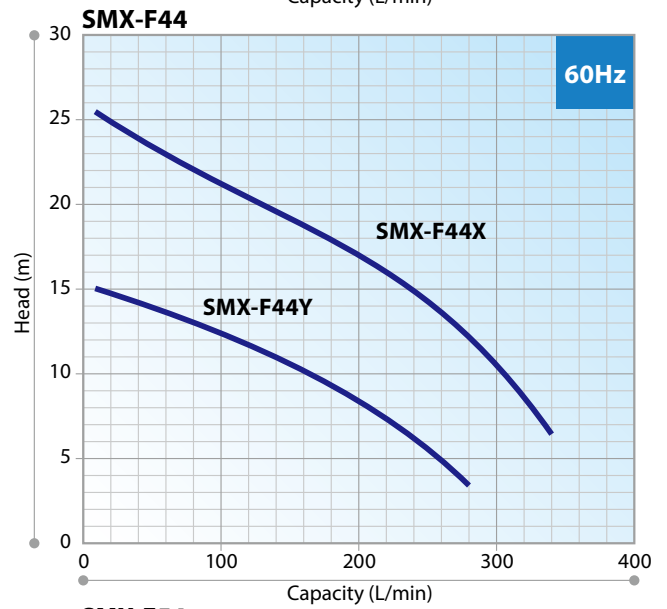
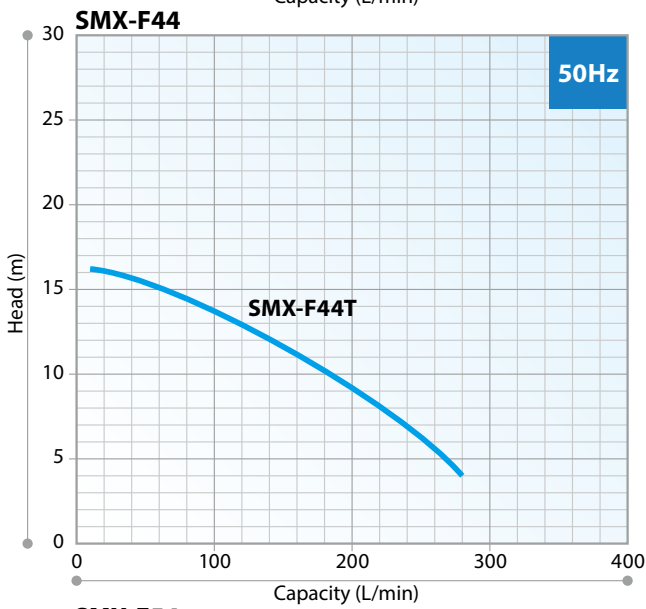
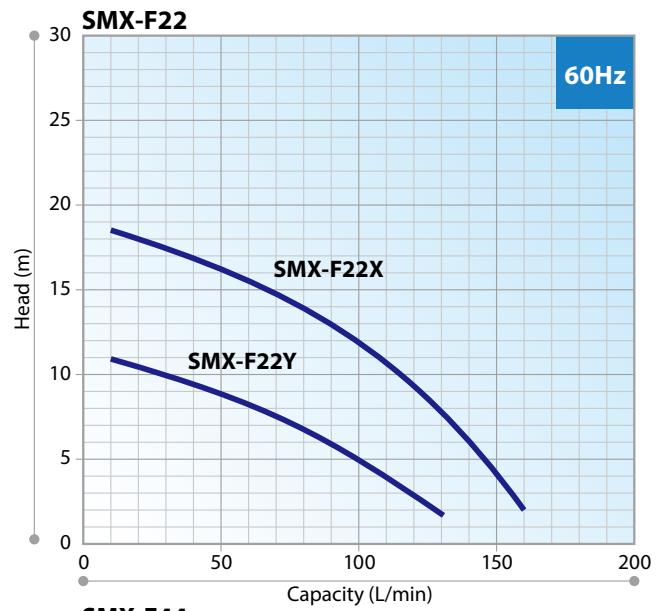
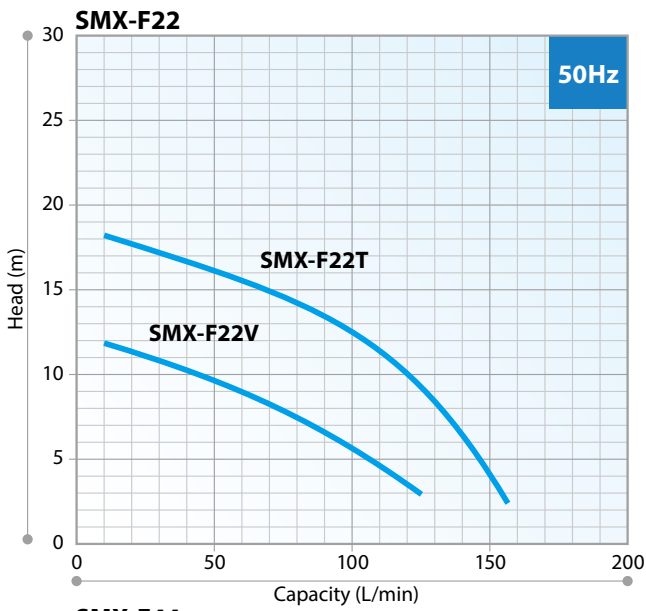



Liquid end Material
CFRETFE

MX-F series

- Self-radiating structure
- Dual section volute casing
- Robust structure
- Excellent chemical resistance

Specifications (50/60Hz)

Max. discharge capacity.....510 L/min
 Max. discharge head29.5/27 m
 MaterialCFRETFE
 Power range0.26 to 2.2kW
 Pump size (Discharge).....G1, 25A to 40A
 Liquid temp. range.....0 to 80°C*
 Specific-gravity limit2.0
 (For details, please contact IWAKI.)
 Sealing method.....Seal-less construction

Liquid end Materials

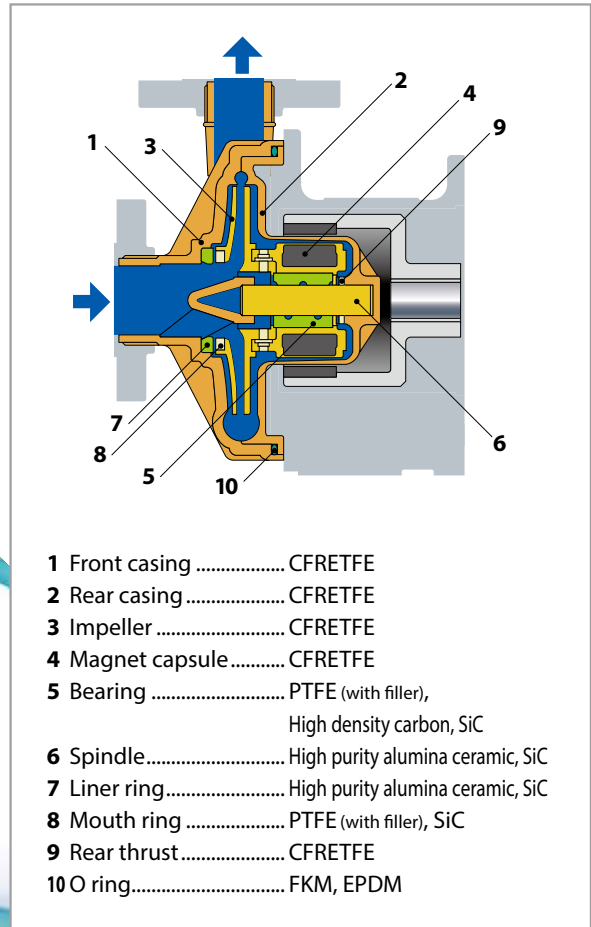

**Chemically Resistant Magnetic Drive
Pumps Built to Withstand
Abnormal Operation**

Performance Curves

• Pump size (Suction×Discharge)

MX-F100: G1×G1, MX-F250/251: 25A×25A, MX-F400: 40A×40A

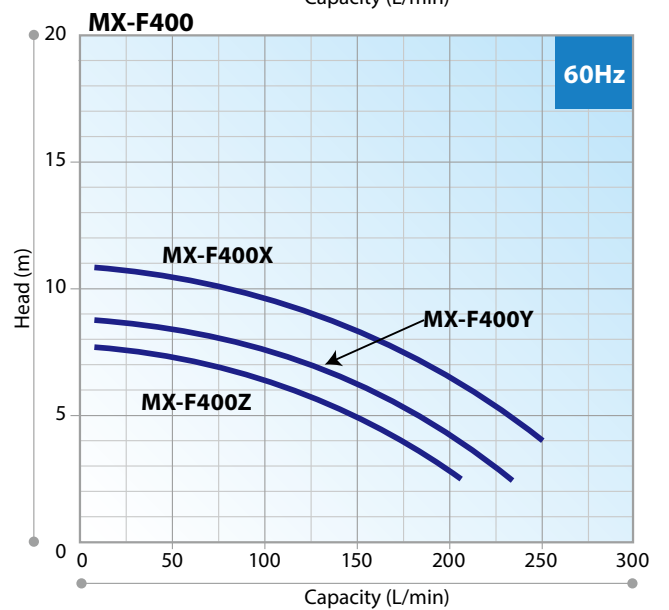
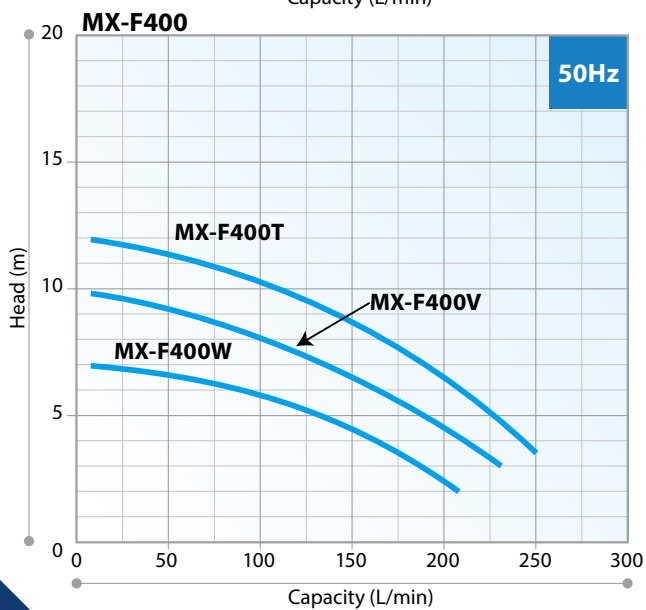
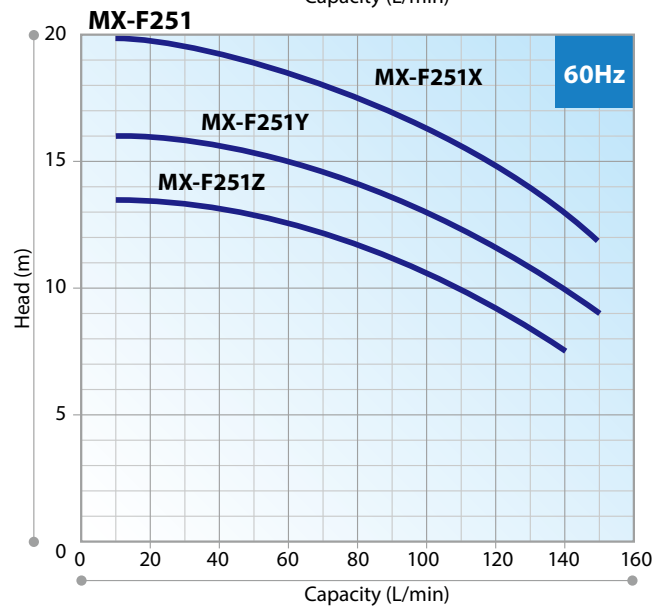
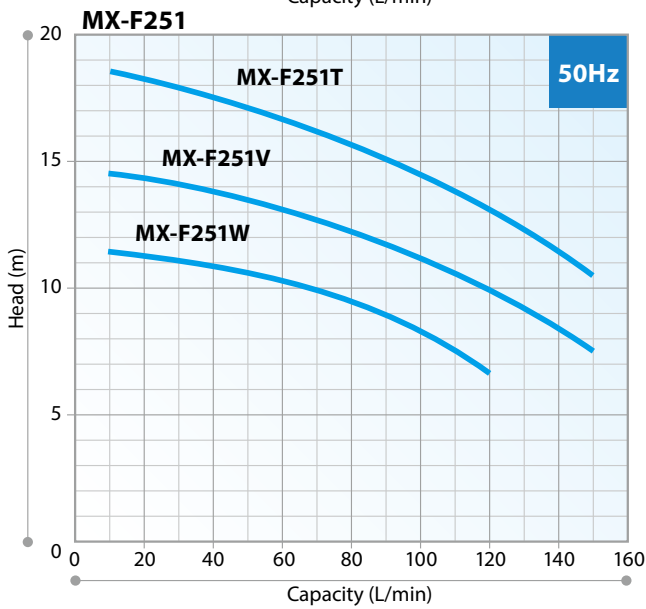
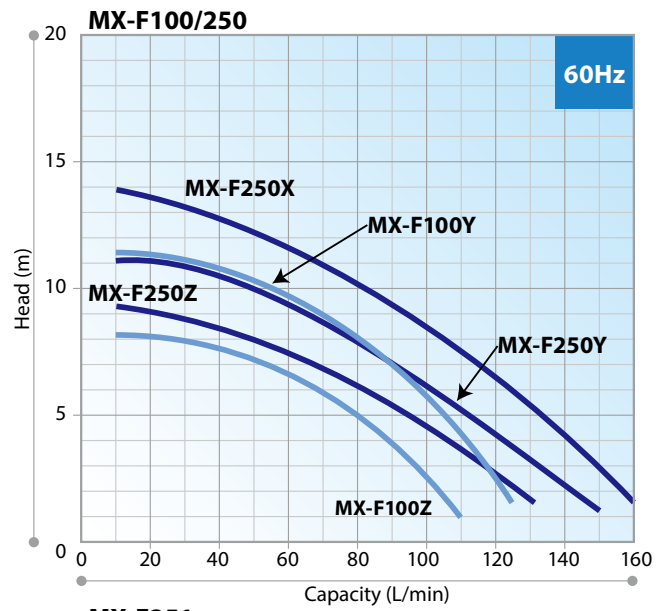
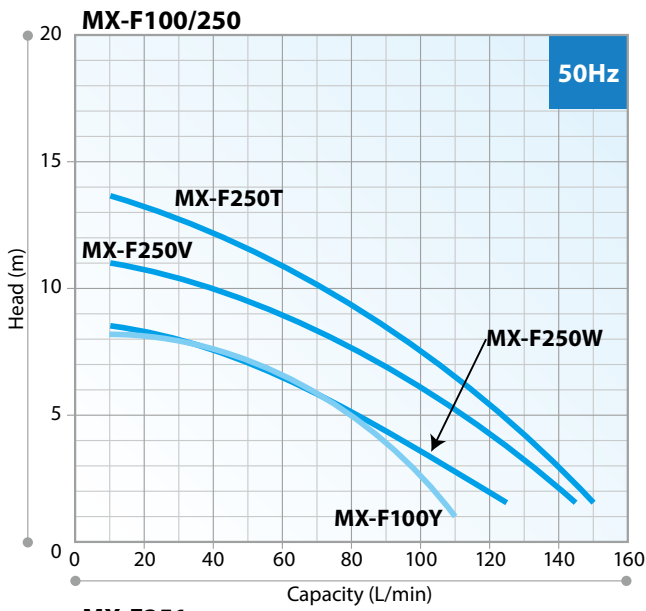

Continued

Performance Curves

• Pump size (Suction×Discharge)MX-F401: 40A×40A, MX-F402/403: 50A×40A

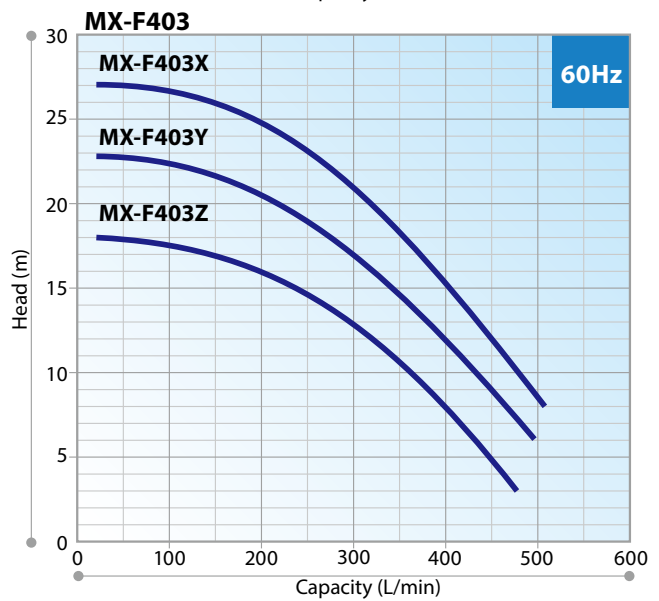
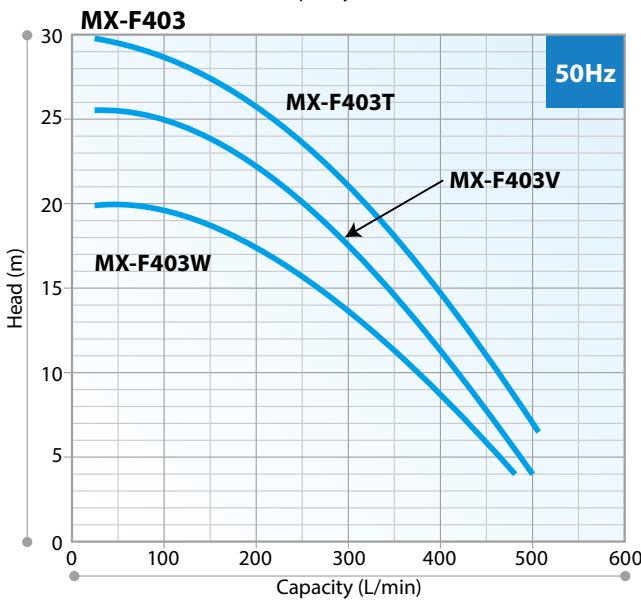
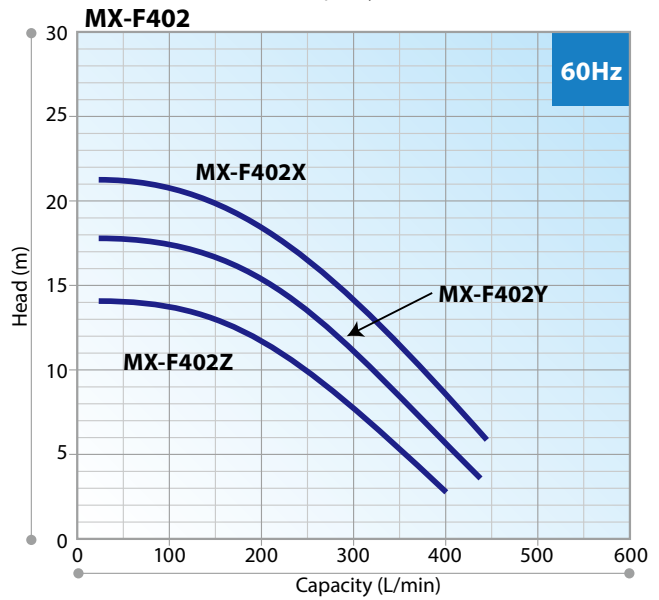
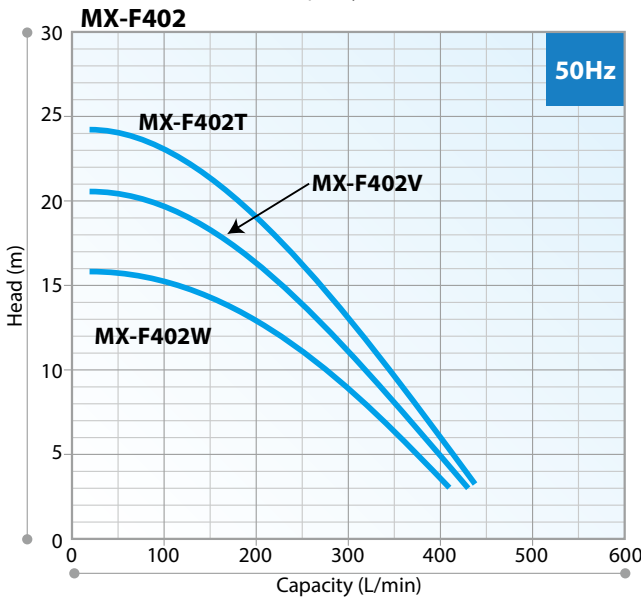
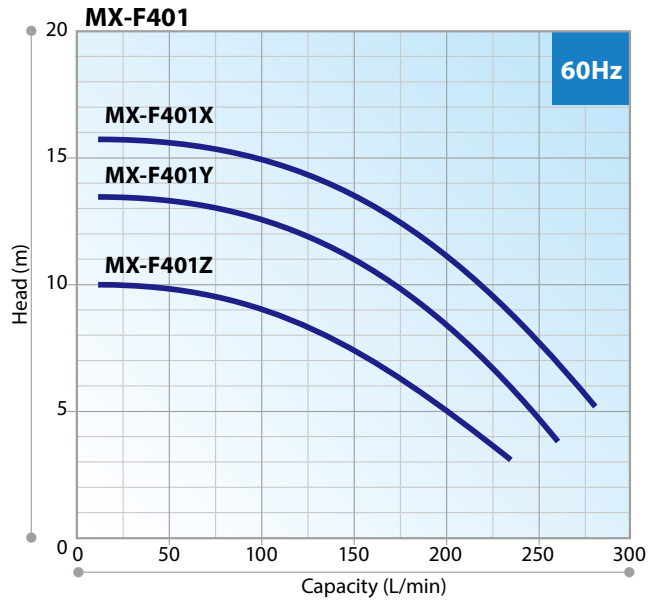
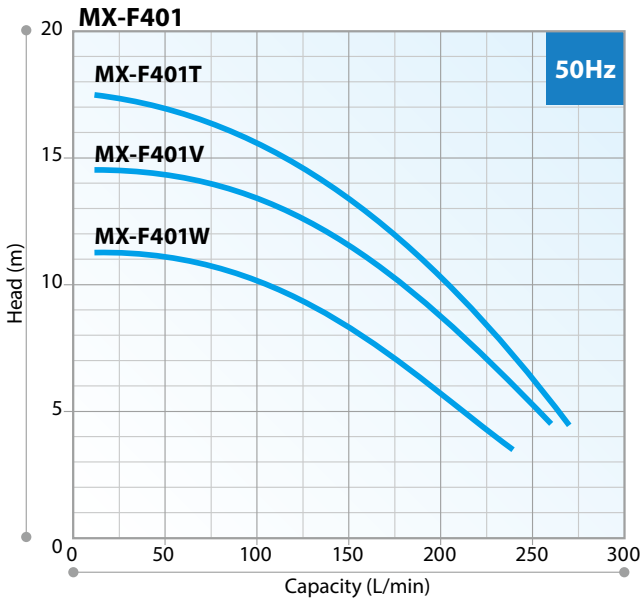

Performance Comparison for IWAKI Magnetic Drive Pumps

Materials: Polypropylene (CFRPP/GFRPP)

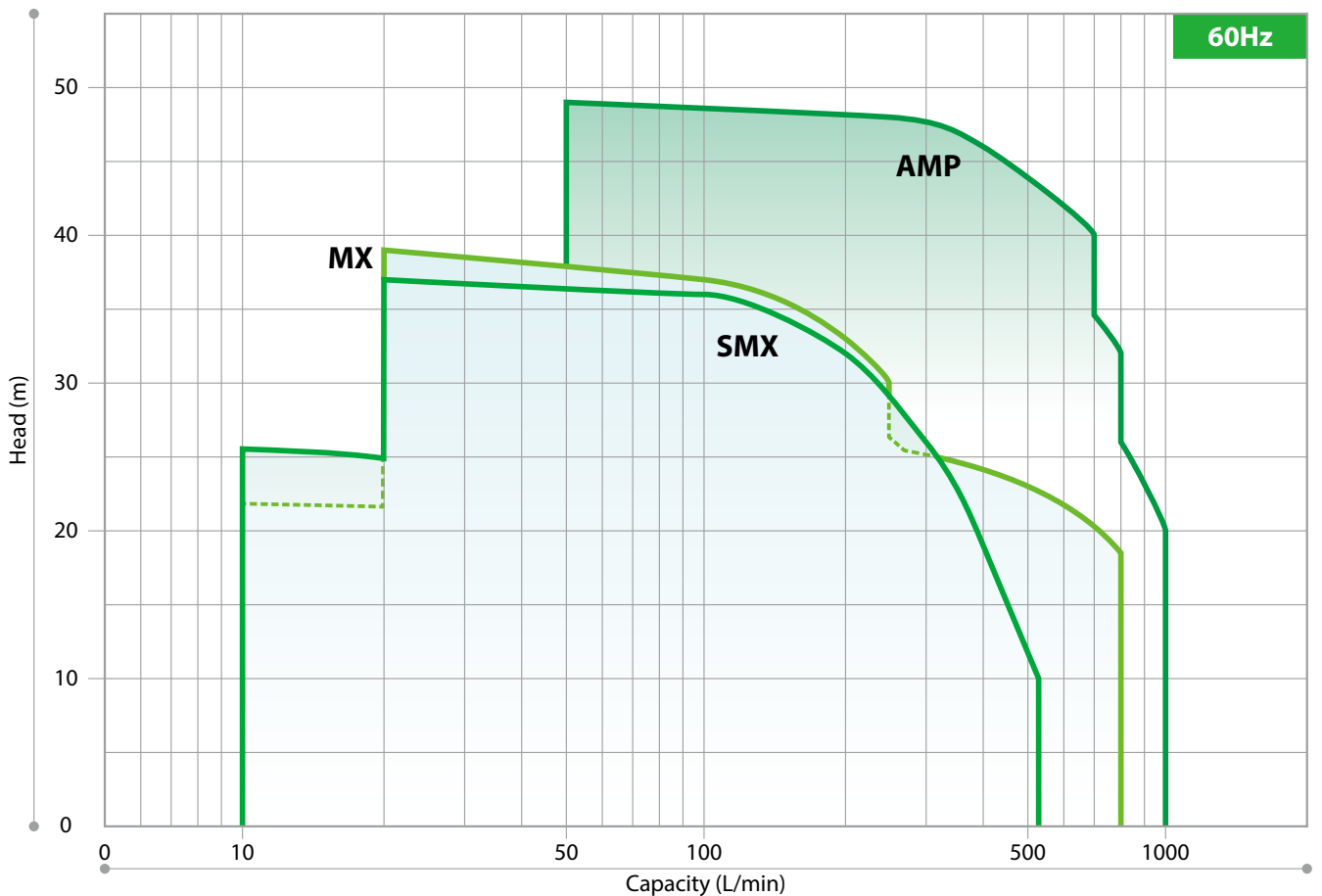
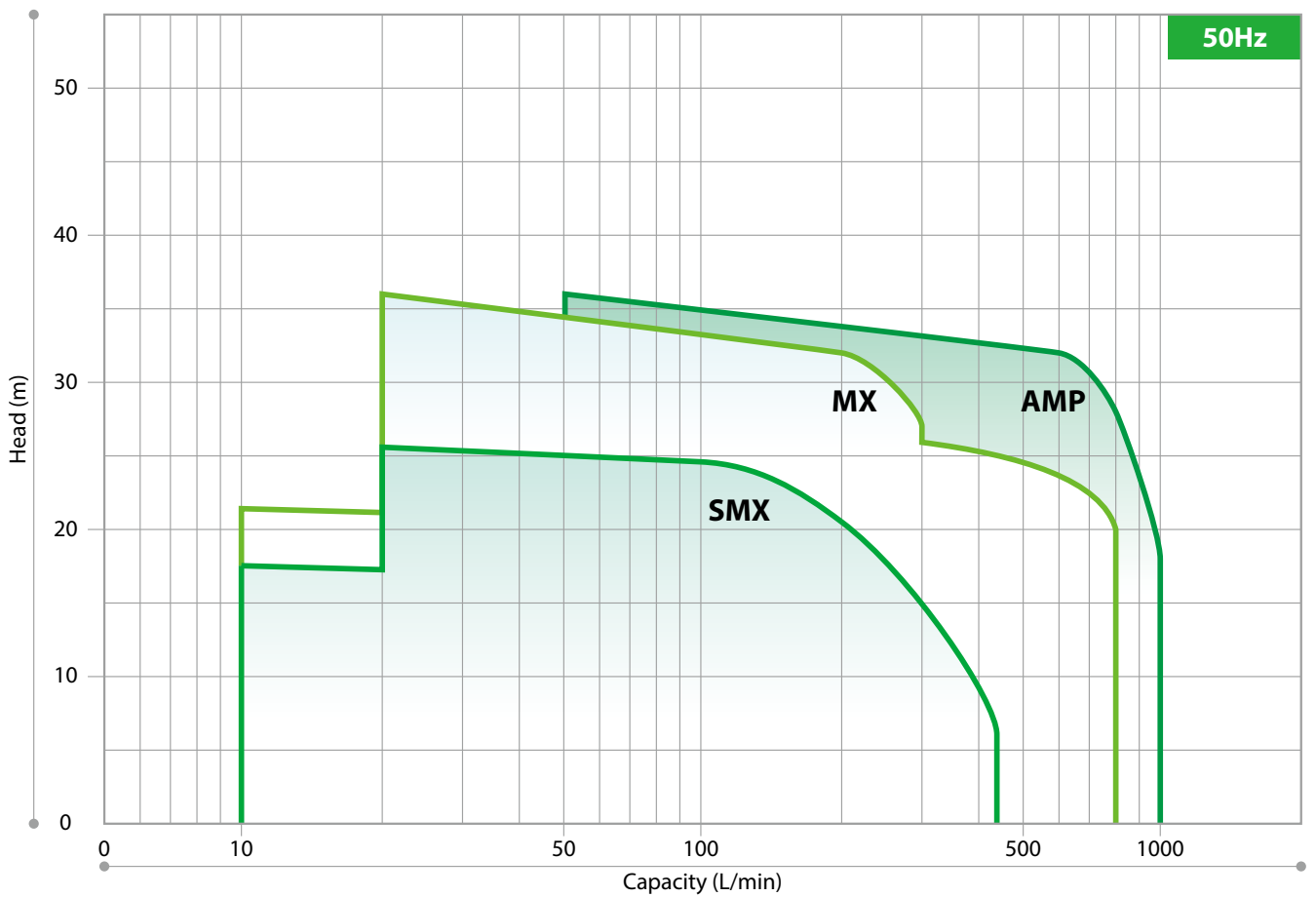

Liquid end Materials



Polypropylene
(CFRPP/GFRPP)

Materials

Model	Resin parts				Sliding parts		Sealing parts	
	Front casing	Rear casing	Impeller	Magnet capsule	Bearing	Spindle	Gasket	O ring
AMP	CFRPP	CFRPP	CFRPP	CFRETFE	High density carbon SiC	High purity alumina ceramic SiC	PTFE	—
SMX	GFRPP	GFRPP	GFRPP	PP	Carbon PTFE (with filler) SiC	High purity alumina ceramic SiC	FKM EPDM	FKM EPDM
MX	GFRPP	GFRPP	GFRPP	PP	PPS PTFE (with filler) Carbon Alumina ceramic	Alumina ceramic High purity alumina ceramic	—	FKM EPDM

Material Index

Plastic materials	
PP	Polypropylene
CFRPP	Carbon fiber-reinforced PP
GFRPP	Fiberglass-reinforced PP
PTFE	Polytetrafluoroethylene ("Teflon" etc.)

Rubber	
FKM	Fluorine rubber ("VITON", "AFLAS" etc.)
EPDM	Ethylene propylene rubber

Materials for sliding parts/bearings	
Carbon	Carbon
High-density carbon	Hard carbon
Alumina ceramic	Alumina ceramic
Highly purity alumina ceramic	Alumina ceramic with a purity of 99.5% or more
SiC	Silicon carbide ceramic
PPS	Polyphenylene sulfide



Liquid end Material
CFRPP

AMP series

- Highly durable structure
- Unique design prevents abnormal operation
- Back pullout design
- Modular design and low maintenance costs

Specifications (50/60Hz)

Max. discharge capacity.....1000 L/min
 Max. discharge head36/49 m
 MaterialCFRPP
 Power range3.7 to 7.5kW
 Pump size (Discharge)40A, 50A
 Liquid temp. range.....0 to 80°C*
 Specific-gravity limit2.0
 (For details, please contact IWAKI.)
 Sealing method.....Seal-less construction
 *Fluid dependent.

Liquid end Materials

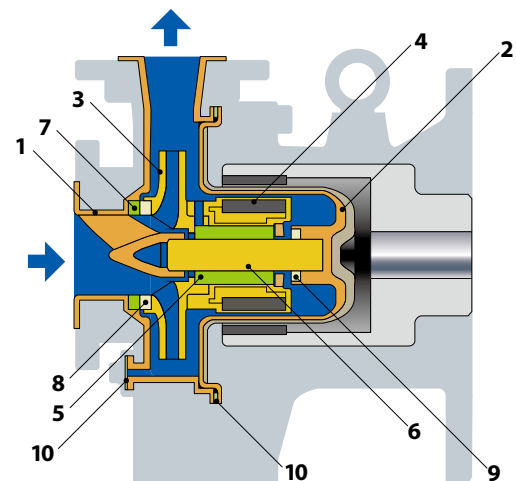

- 1 Front casing CFRPP
- 2 Rear casing CFRPP
- 3 Impeller CFRPP
- 4 Magnet capsule CFRETFE
- 5 Bearing High density carbon, SiC
- 6 Spindle..... High purity alumina ceramic, SiC
- 7 Liner ring..... High purity alumina ceramic, SiC
- 8 Mouth ring PTFE (with filler), SiC
- 9 Rear thrust..... PTFE
- 10 Gasket PTFE

Polypropylene Magnetic Drive Process Pumps



Performance Curves

• Pump size (Suction×Discharge)

AMP40: 50A×40A, AMP50: 65A×50A

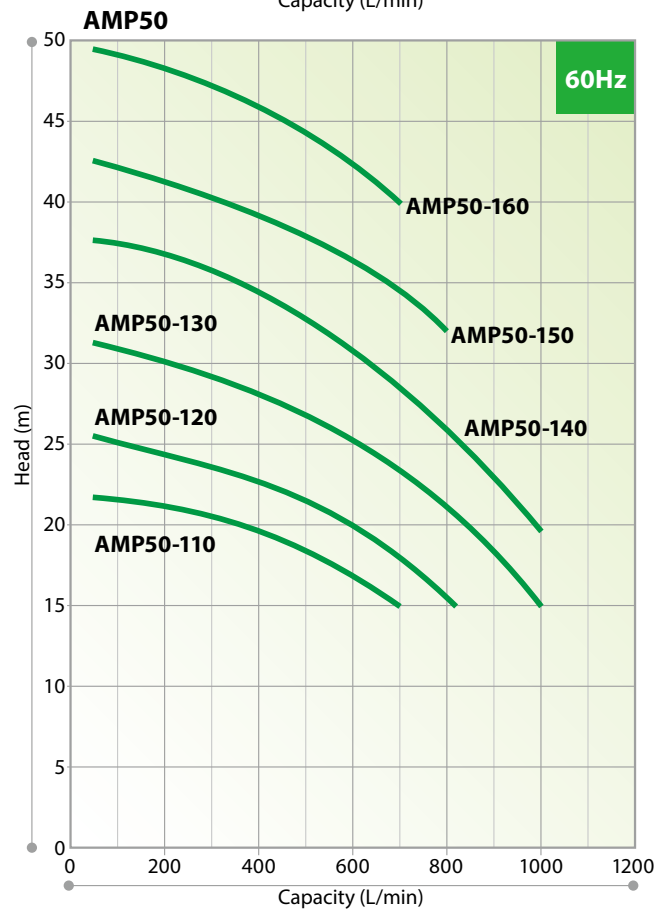
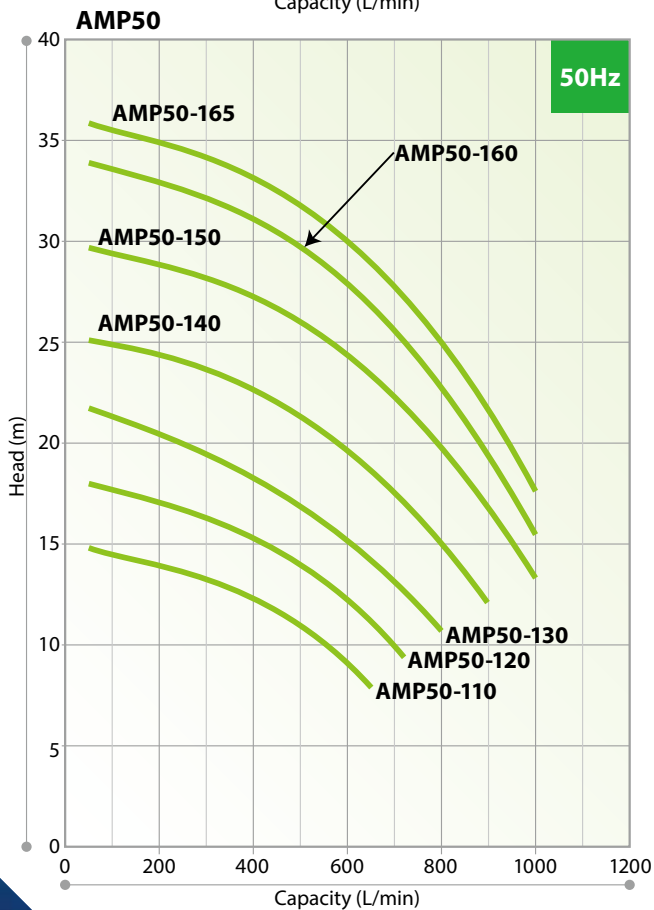
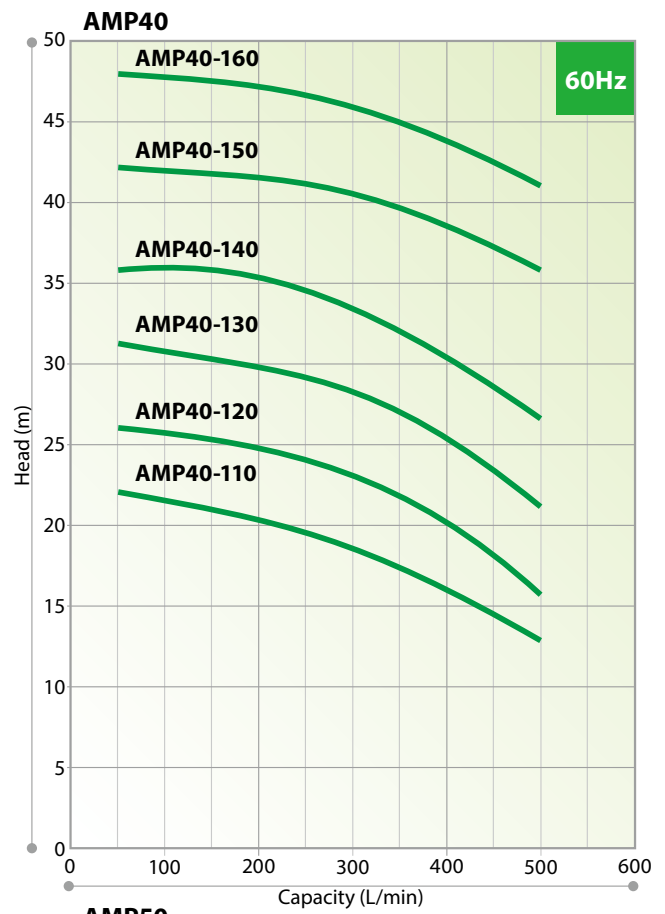
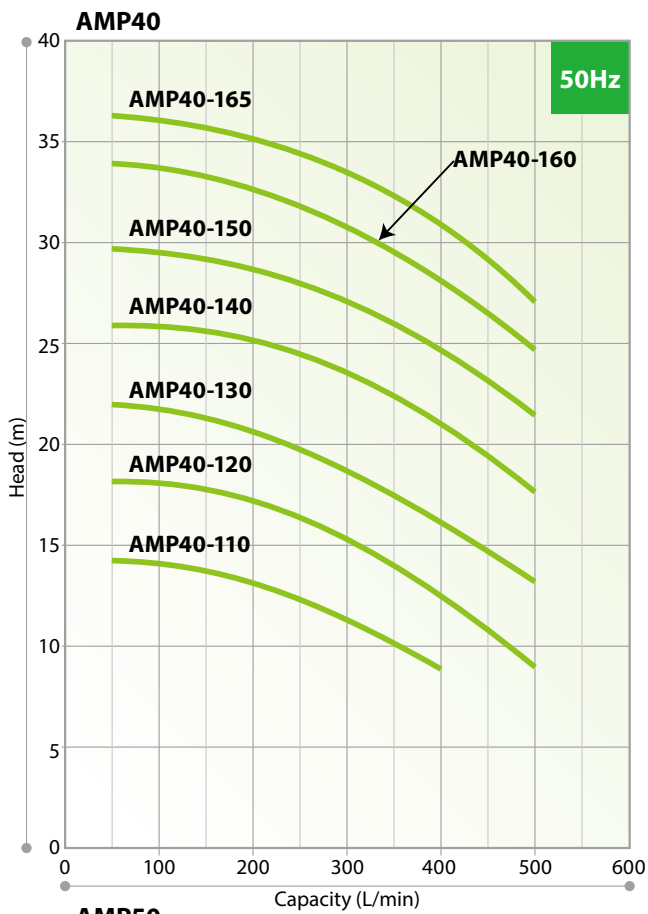



Liquid end Material
GFRPP

SMX series

- Expanded versatility
- Easy maintenance
- Able to withstand abnormal operation
- Fast self-priming

Specifications (50/60Hz)

Max. discharge capacity.....440/520 L/min
 Max. discharge head25.5/37.5 m
 Rated self-priming height4m
 MaterialGFRPP
 Power range0.4 to 3.7kW
 Pump size (Discharge)25A, 40A
 Liquid temp. range.....0 to 80°C*
 Specific-gravity limit2.0
 (For details, please contact IWAKI.)
 Sealing method.....Seal-less construction

*Fluid dependent.

Liquid end Materials

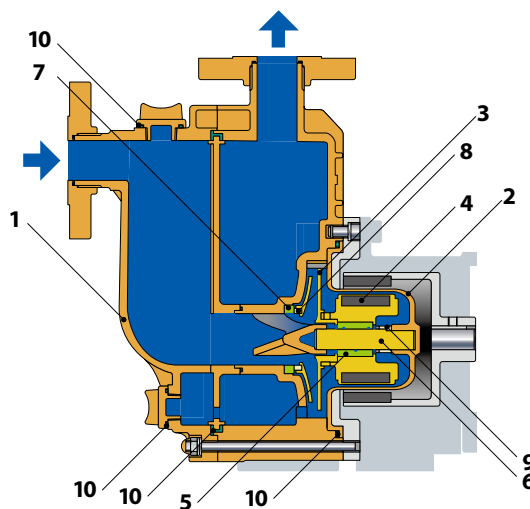

- 1 Front / Rear case..... GFRPP
- 2 Rear casing GFRPP
- 3 Impeller GFRPP
- 4 Magnet capsule..... PP
- 5 Bearing Carbon, SiC, PTFE (with filler)
- 6 Spindle..... High purity alumina ceramic, SiC
- 7 Liner ring..... Alumina ceramic
- 8 Mouth ring PTFE (with filler)
- 9 Rear thrust High purity alumina ceramic, SiC, CFRETFE
- 10 O ring..... FKM, EPDM

**Versatile Self-Priming
Magnetic Drive Pumps Built to
Withstand Abnormal Operation**



Performance Curves

• Pump size (Suction×Discharge)

SMX22: 25A×25A, SMX44: 40A×40A, SMX54: 50A×40A

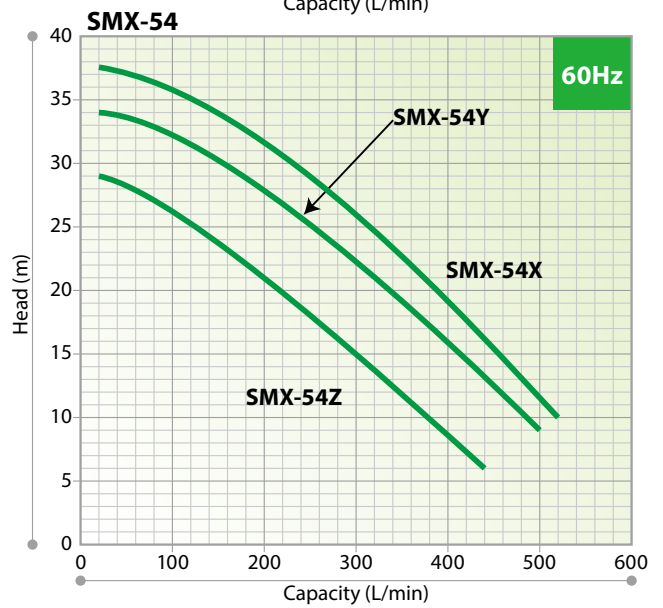
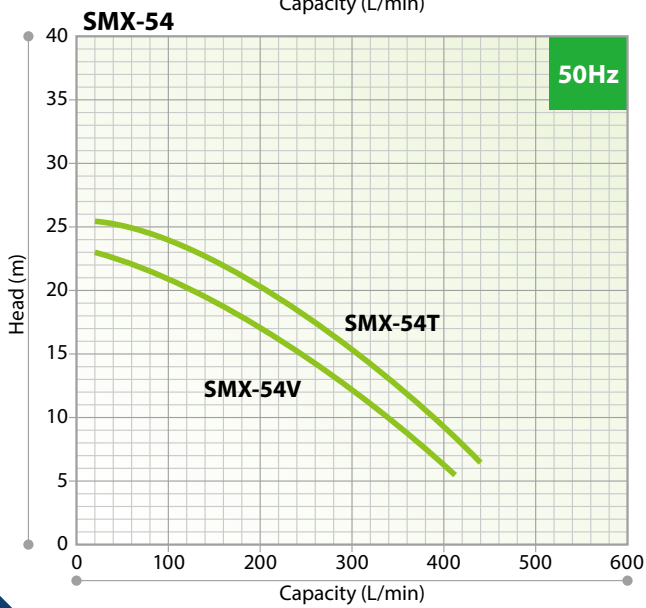
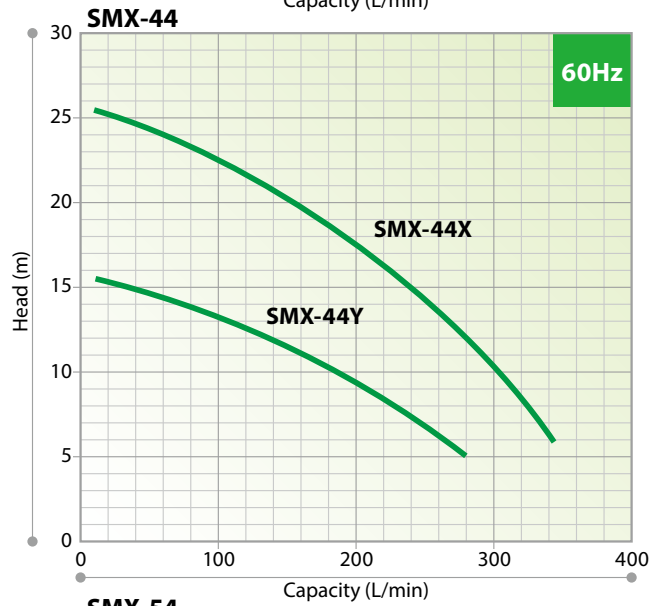
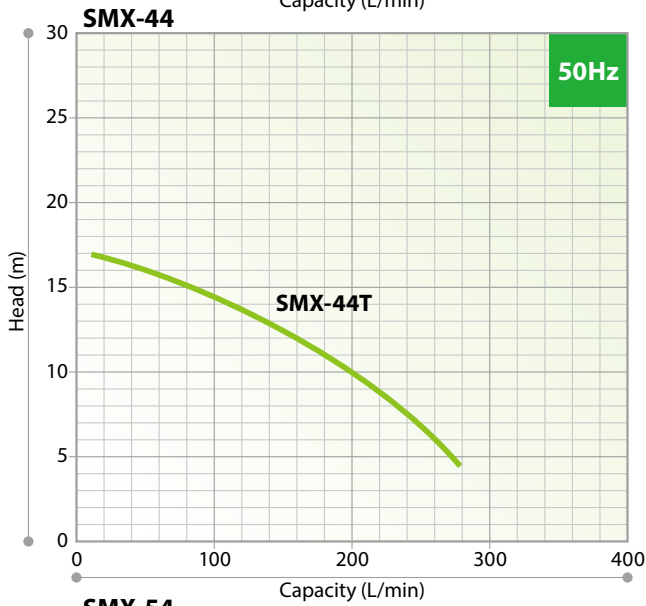
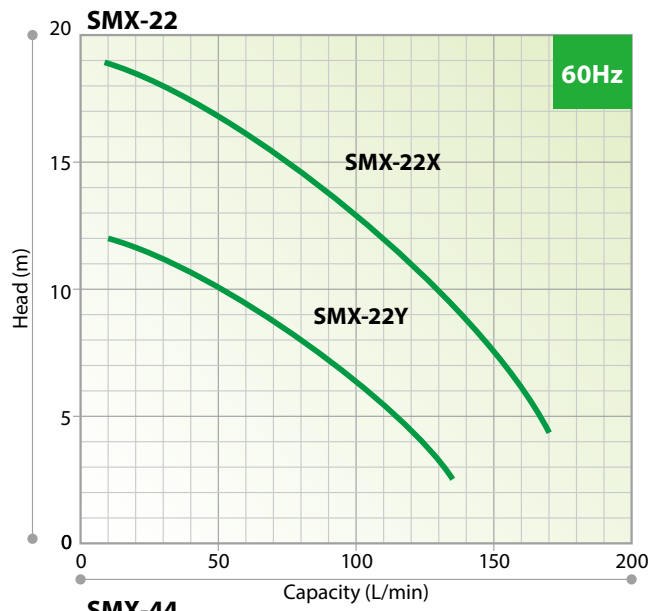
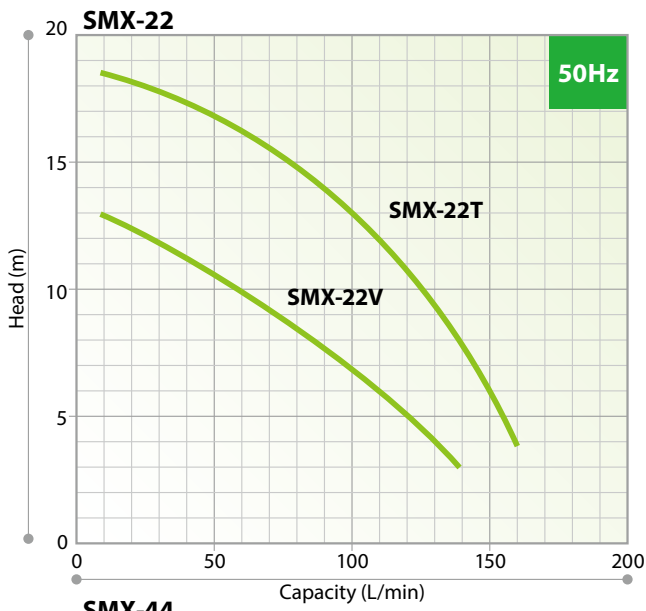



Liquid end Material
GFRPP

MX series

- Self-radiating structure
- Non-contact structure
- Dual section volute casing
- Robust structure

Specifications (50/60Hz)

Max. discharge capacity.....800 L/min
 Max. discharge head35/37 m
 MaterialGFRPP
 Power range0.15 to 2.2kW
 Pump size (Discharge)G1, 25A to 50A
 Liquid temp. range.....0 to 80°C
 Specific-gravity limit2.0
 (For details, please contact IWAKI.)
 Sealing method.....Seal-less construction

Liquid end Materials

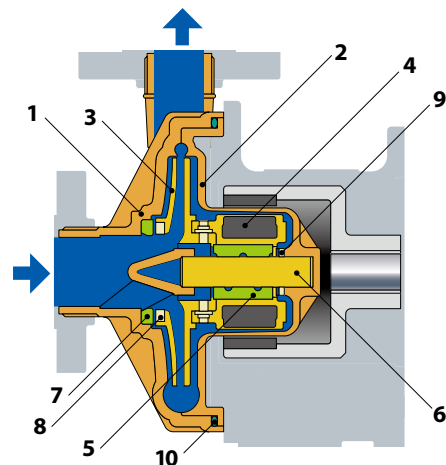

- 1 Front casing GFRPP
- 2 Rear casing GFRPP
- 3 Impeller GFRPP
- 4 Magnet capsule..... PP
- 5 Bearing PPS, PTFE (with filler), Carbon,
High purity alumina ceramic
- 6 Spindle..... High purity alumina ceramic
- 7 Liner ring..... High purity alumina ceramic
- 8 Mouth ring PTFE (with filler)
- 9 Rear thrust CFRETFE
- 10 O ring..... FKM, EPDM

**Built to Withstand
Abnormal Operation
and Provide High Efficiency**

Performance Curves

• Pump size (Suction×Discharge)

MX-70/100: G1×G1, MX250/251: 25A×25A, MX400/401: 40A×40A

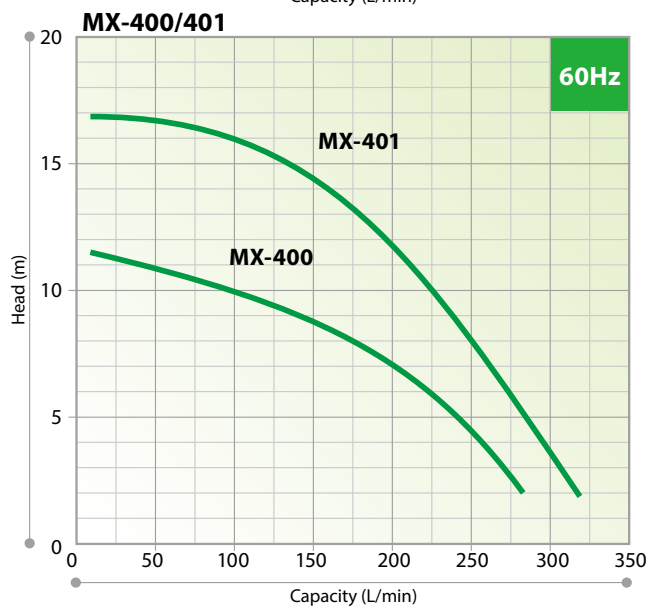
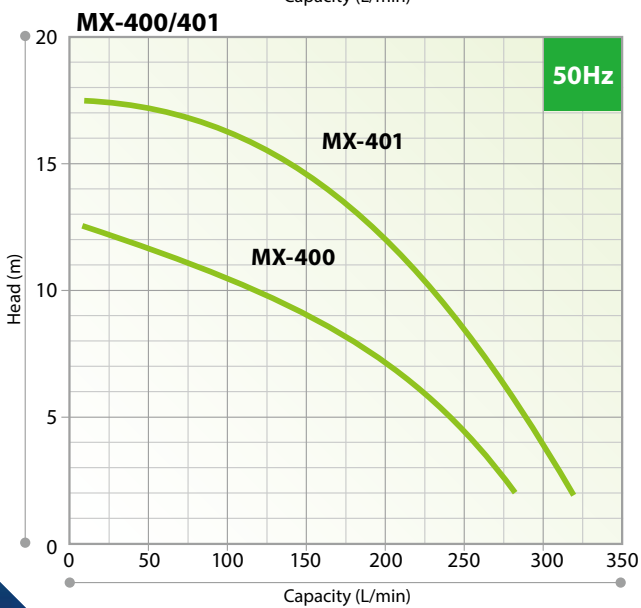
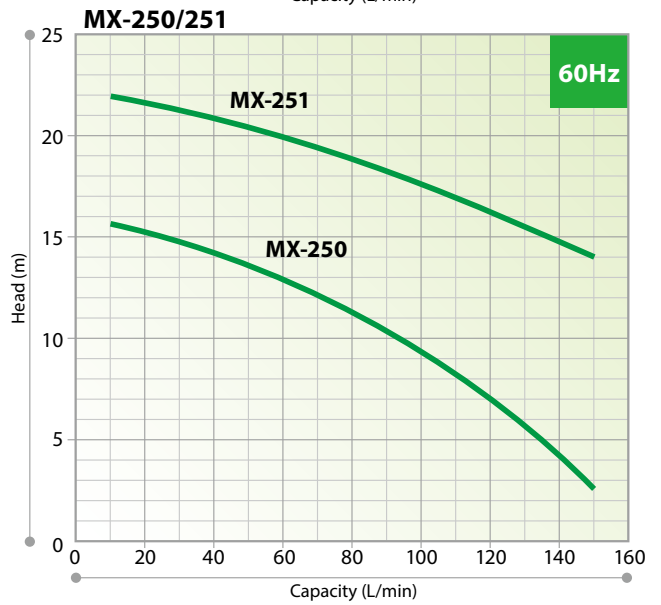
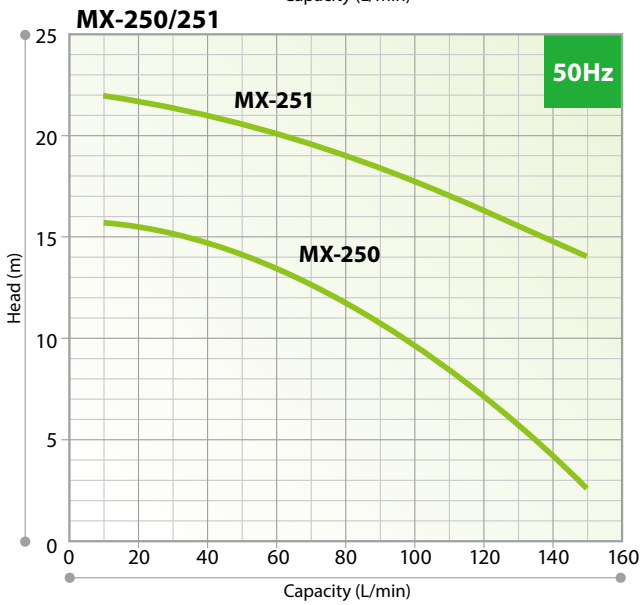
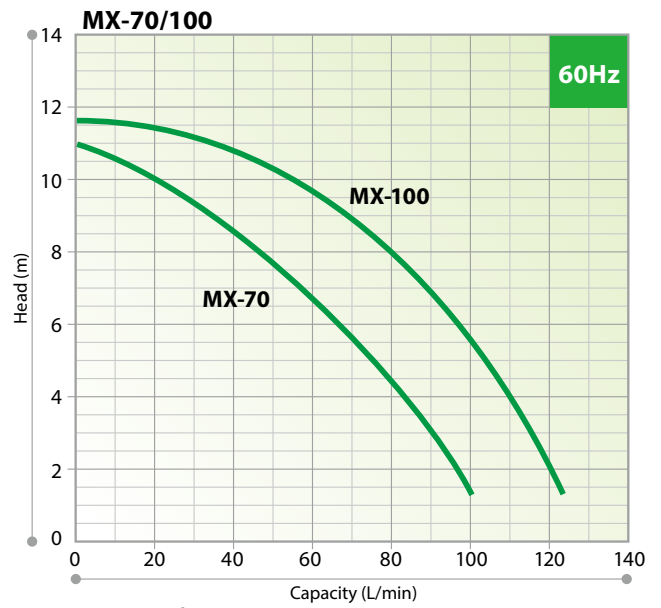
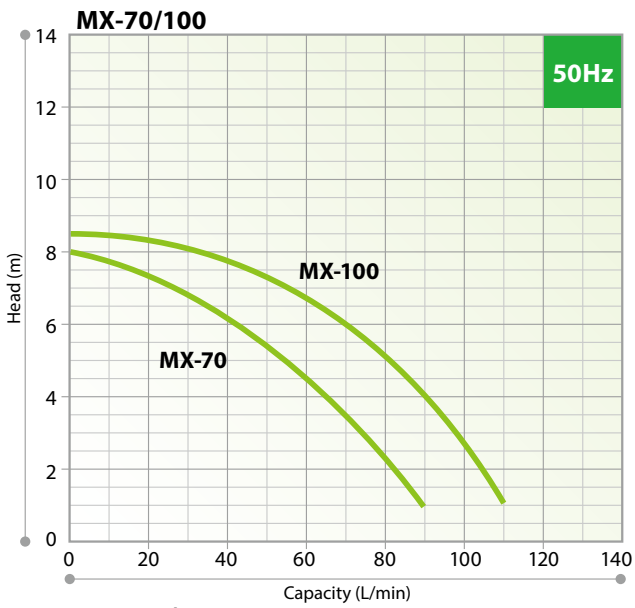

Continued

Performance Curves

• Pump size (Suction×Discharge)

MX402/402H/403/403H: 50A×40A, MX505: 65A×50A

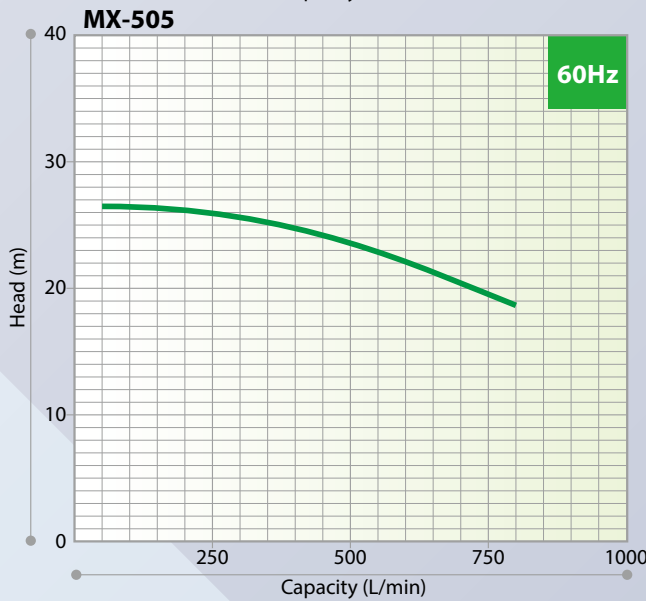
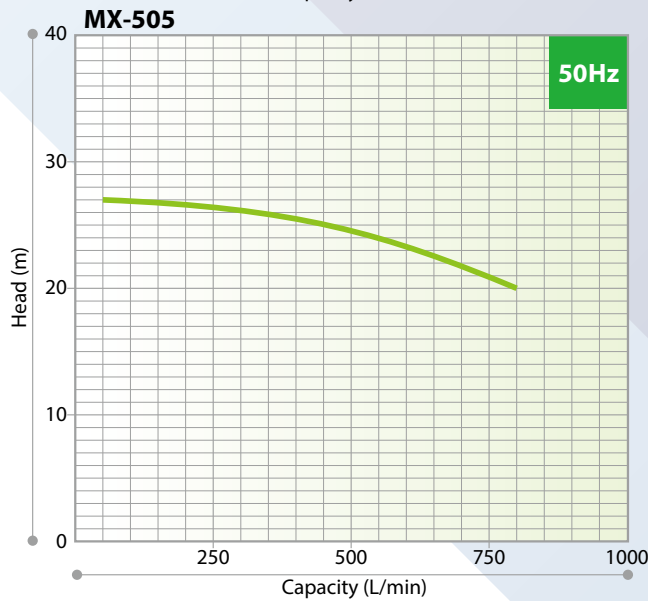
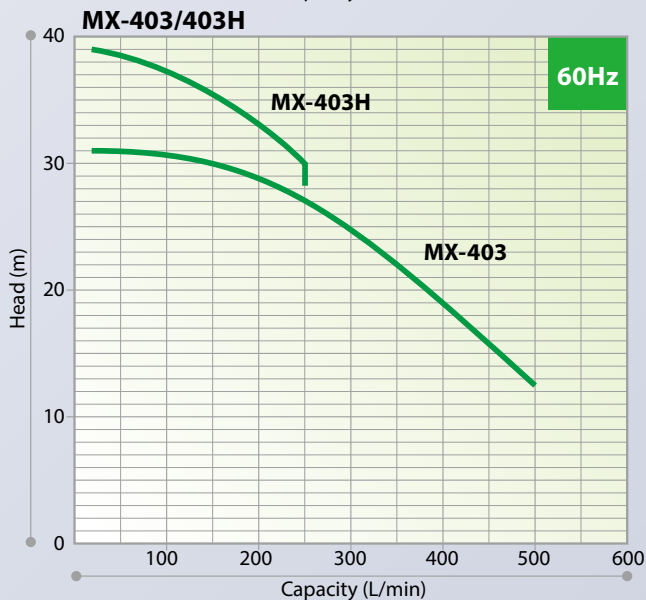
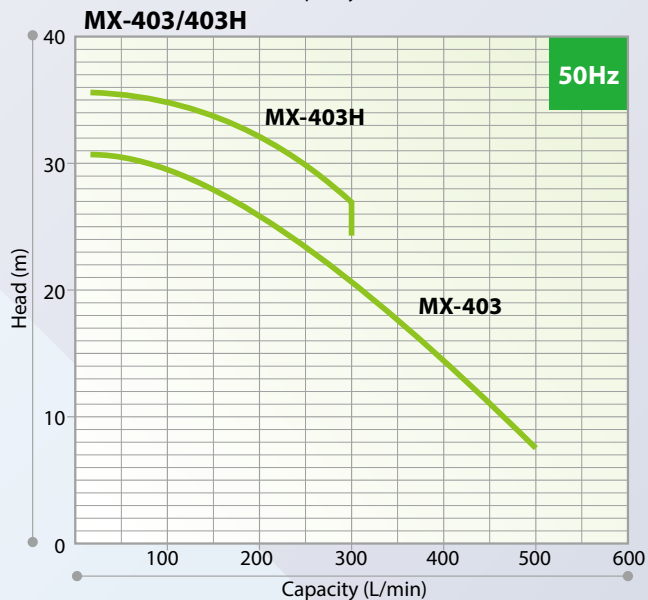
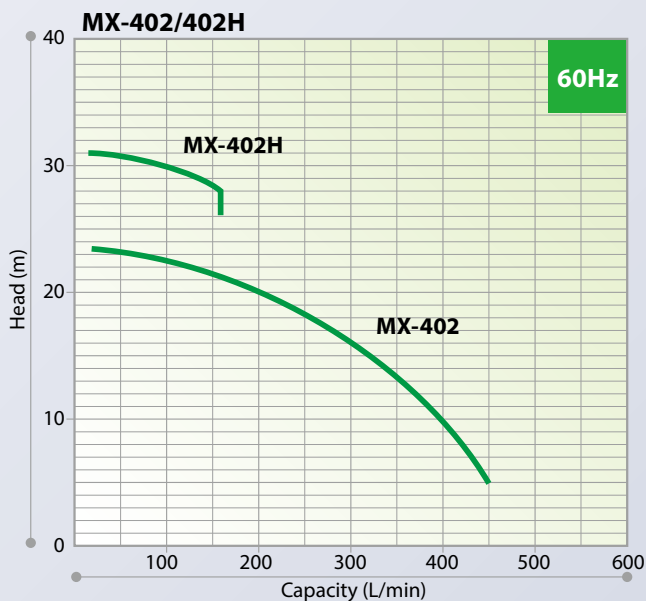
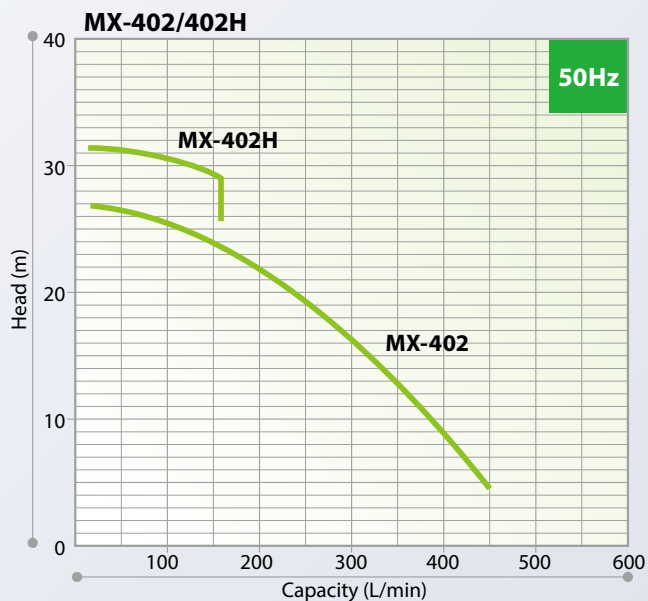

Precautions in Piping Planning

To safely use the full capability of a pump, observe the precautions below when performing installation.

MDW/MDE/MDM/MXM/AMP/MX/MX-F series

1. Suction tank

- Capacity**
Make sure the tank has enough capacity. Even if the liquid level fluctuates by operating the pump, make sure that no gas is involved. If gas entrainment operation is performed, lubrication of the sliding parts will be insufficient, causing damage to the pump.
- Prevention of convection**
Install a rectifying plate in the suction tank to prevent convection. If there is a flow at the part where the suction pipe is taken out, it may cause suction failure.
- Foreign matter prevention**
Install a screen in the suction tank to prevent foreign matter from entering the pump. In addition, it is important to prevent foreign matter from entering the suction tank from the supply side. Note that installing a strainer in the suction pipe creates resistance and may cause damage to the pump.

2. Suction pipe

- Flooded suction**
Establish a flooded suction system. A suction lift system is much less efficient and so it is not recommended. In the case a suction lift system, a foot valve is always required.
- Pipe resistance**
Establish the shortest line length and the minimum number of bends so the pipe resistance is minimized.
- Piping diameter**
The pipe diameter should be larger than the suction diameter of the pump. As a guideline for selection, select a pipe diameter that allows the flow velocity in the pipe to be 1.5m/s or less. If the flow velocity is too high, it will be affected by air accumulation, etc., and suction failure will easily occur.
Example : For a flow rate of 1,200L/min (1.2m³/min)

$$d = \sqrt{\frac{4 \times Q}{V \times \pi}}$$

$$= \sqrt{\frac{4 \times (1.2/60)}{1.5 \times \pi}}$$

$$= 0.13(\text{m})$$

d : Pipe diameter (m)
 Q : Flow rate (m³/s)
 V : Flow speed (m/s)
 Appropriate pipe diameter is 150A

- Independent piping**
Provide an independent suction pipe for each pump. Collective piping is affected by the flow of each pump, and suction failure may occur. In the unlikely event that independent piping is difficult and should be used as a collective pipe, select a pipe diameter that allows the flow velocity of the collective pipe to be 0.5m/s or less.
- Shut off valve**
In the case of the push-in type, a shut off valve is required when disassembling and inspecting the pump, so be sure to install it.
- Tip of suction line**
Always submerge at least 500 mm above the liquid surface to prevent air from being sucked in.
- Straight section**
Be sure to provide a straight pipe section immediately before the suction port

of the pump. If there is a bend in the pipe just before the pump and the liquid flow is uneven, the pump will become unstable and cause failure.

- 50A (2B) or smaller: 500mm
 - 65A (2½B) or wider: 8 times longer than the pump inlet I.D.
- In addition, install a removable short pipe of about 300 mm in the straight pipe section for disassembly and inspection of the pump.
- No air/gas entrapment**
In general, do not allow any arched line where air may be trapped. In a flooded suction system, lay a suction line in the down-slope (from the tank outlet to the pump inlet) of 1:100 or steeper. In a suction lift system; however, lay it in the up-slope to the pump inlet. If plumbing latitude is limited in your facility and you can not avoid an arched suction line in the system, mount an air vent device.
 - Use of reduced diameter pipe**
If the suction pipe has a diameter different from that of the pump, use an eccentric single drop pipe. The single drop pipe is laid so that the upper part is horizontal so that air does not accumulate.
 - Joint**
Minimize the number of joints in the suction pipe as much as possible. When installing joints, make sure they are properly sealed. If the seal is defective, air will be sucked into the pump, making it impossible to pump liquid, or the lubrication inside the pump will be insufficient, resulting in pump failure.
 - NPSH**
After designing the piping, check the NPSH. Observe the following conditions to prevent cavitation.
 $NPSH_a \geq NPSH_r + 0.5\text{m}$
 $NPSH_a$: (Available NPSH) Value determined by piping and transferred liquid
 $NPSH_r$: (Required NPSH) Value determined by pump model

3. Discharge pipe

- Shut off valve**
Install a shut off valve near the pump discharge port (within 1m) to prevent overload at startup and to adjust the discharge rate.
- Air vent pipe**
Install an air vent pipe between the pump and the shut off valve (check valve) near the pump, and be sure to release the air before operation. If the air in the pump is not sufficiently vented, the liquid may not be pumped or the temperature inside the pump may rise abnormally, resulting in malfunction. Also, if air remains between the pump and the valve close to the pump, the magnetic coupling may go out of step at startup. Air stagnation also has a harmful effect on the discharge piping downstream of the gate valve, so provide an air vent piping as necessary.
- Check valve**
Install a check valve in the following cases.
 - Discharge line is longer than 15m.
 - A delivery head is higher than 15m.
 - The top end of a discharge line is 9m or higher than the tank liquid level.
 - Several pumps run in parallel.
 If a check valve is installed, air may accumulate on the upstream side, so install an air vent pipe. Especially for liquids that generate gas, it is necessary to remove the generated gas before starting the pump.

Before using the pump, be sure to read the instruction manual and use it correctly.

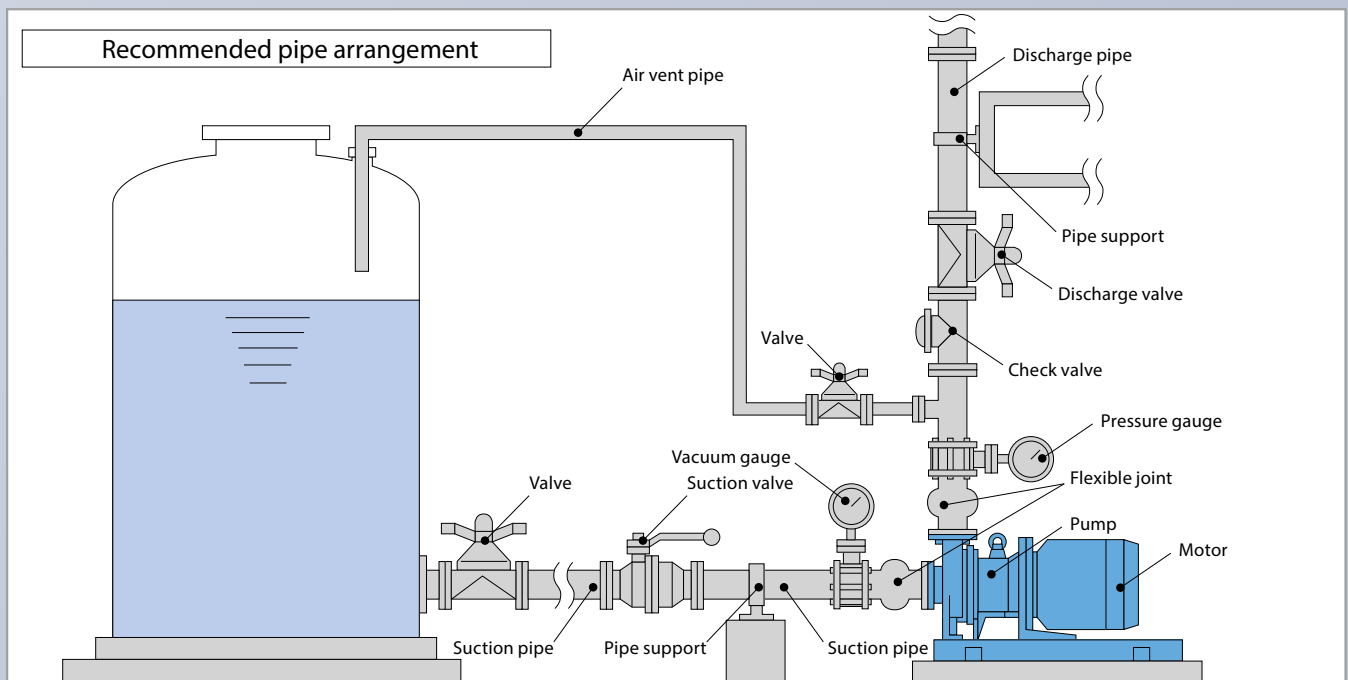

SMX/SMX-F series

1. Suction tank

- Capacity
Make sure the tank has enough capacity. Even if the liquid level fluctuates by operating the pump, make sure that no gas is involved. If gas entrainment operation is performed, lubrication of the sliding parts will be insufficient, causing damage to the pump.
- Prevention of convection
Install a rectifying plate in the suction tank to prevent convection. If there is a flow at the part where the suction pipe is taken out, it may cause suction failure.
- Foreign matter prevention
Install a screen in the suction tank to prevent foreign matter from entering the pump. In addition, it is important to prevent foreign matter from entering the suction tank from the supply side. Note that installing a strainer in the suction pipe creates resistance and may cause damage to the pump.

2. Suction pipe

- Suction lift system
Before operating the pump, be sure to prime it and fill the pump chamber with the liquid to be handled before starting. The self-priming limit height (4m) is the value for liquids equivalent to water and 20°C. Self-priming performance varies depending on liquid temperature, liquid quality, piping conditions, etc. Use the following formula to find the approximate height of specific gravity that allows self-priming.

Self-suction height of specific gravity liquid (reference) [m] = Self-suction height of water [m]/liquid specific gravity

Also, if there is something that acts as a suction resistance (such as a foot valve) in the suction pipe, it may cause a decrease in self-priming capability or impossibility of self-priming. In addition, there is no particular problem even if it is used in Flooded suction. When using the push-in method, please take the same piping considerations as with magnet drive pumps (MX type, etc.).

- Pipe resistance
Keep the length of the pipe within 4.7m, and make it as short as possible with fewer bends. If it is longer than 4.7m, it will not self-suction because the air volume in the suction pipe will be large.
- Piping diameter
The pipe diameter should be larger than the suction diameter of the pump. If the diameter is larger than the suction of the pump, the volume of air in the suction pipe will increase, so the pump will not self-suction.
- Independent piping
Provide an independent suction pipe for each pump. Collective piping is affected by the flow of each pump, and suction failure may occur.
- Shut off valve
In the case of the push-in type, a shut off valve is required when disassembling and inspecting the pump, so be sure to install it.
- Tip of suction line
Always submerge at least 500 mm above the liquid surface to prevent air from being sucked in.

- Straight section
Be sure to provide a straight pipe section of 500 mm or more immediately before the suction port of the pump. In addition, install a removable short pipe of about 300 mm in the straight pipe section for disassembly and inspection of the pump.
- No air/gas entrapment
In general, do not allow any arched line where air may be trapped. In a flooded suction system, lay a suction line in the down-slope (from the tank outlet to the pump inlet) of 1:100 or steeper. In a suction lift system; however, lay it in the up-slope to the pump inlet. If plumbing latitude is limited in your facility and you can not avoid an arched suction line in the system, mount an air vent device.
- Joint
Minimize the number of joints in the suction pipe as much as possible. When installing joints, make sure they are properly sealed. If the seal is defective, air will be sucked into the pump, making it impossible to pump liquid, or the lubrication inside the pump will be insufficient, resulting in pump failure.
- Pipe support
If piping weight loads the pump, any plastic part is deformed. Be sure to install a pipe support.

3. Discharge pipe

- Shut off valve
Install a shut off valve near the pump discharge port (within 1m) to prevent overload at startup and to adjust the discharge rate. Also, during self-priming operation, open either the discharge pipe or the air release pipe to the atmosphere.
- Air vent line
An air vent line should be arranged in the following cases
 - An horizontal discharge line is 10m or more.
 - A check valve is installed. Otherwise self-priming can not be performed.
 - A discharge line is not at atmospheric pressure. Otherwise self-priming can not be performed.
- Check valve
When selecting a check valve, check its maximum operating pressure to make sure it tolerates a possible pressure rise due to water hammer or back flow.
 - Discharge line is longer than 15m.
 - A delivery head is higher than 15m.
 - The top end of a discharge line is 9m or higher than the tank liquid level.
 - Several pumps run in parallel.
- Straight section
Provide a vertical straight pipe section of 500 mm or more immediately after the pump to release air during self-priming operation.
- Pipe support
If piping weight loads the pump, any plastic part is deformed. Be sure to install a pipe support.

Before using the pump, be sure to read the instruction manual and use it correctly.

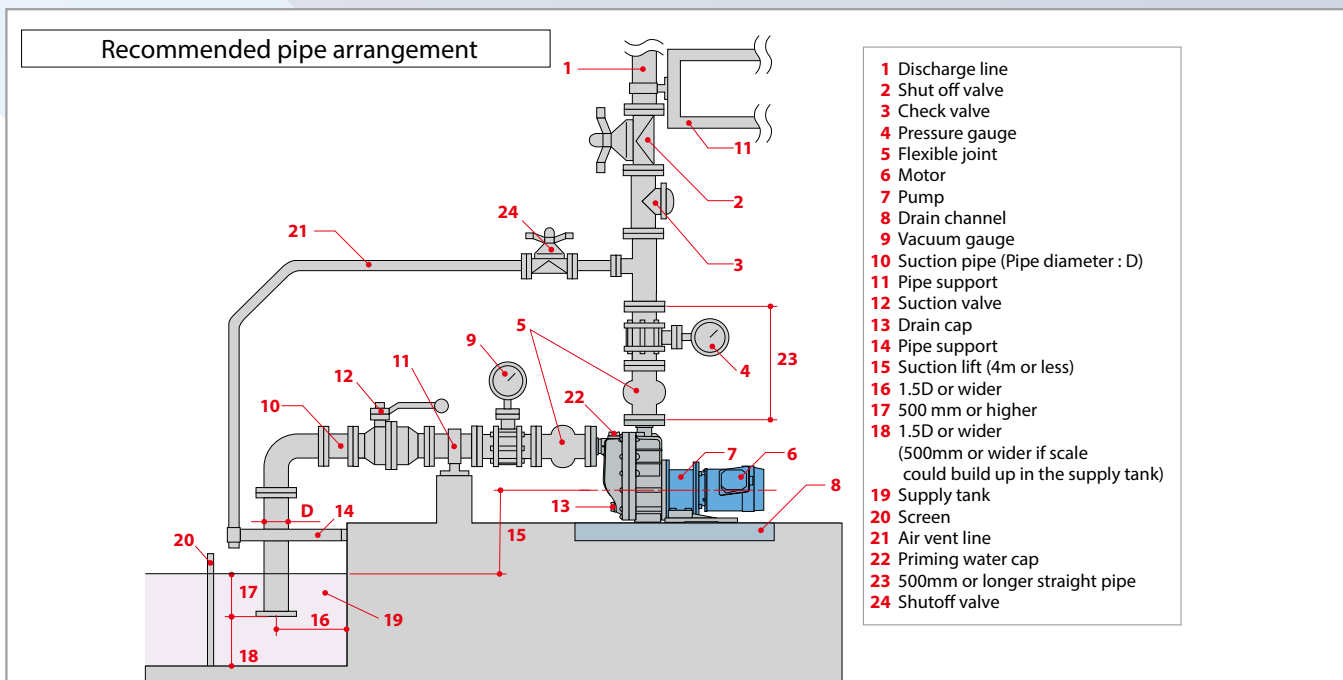

Optional Accessories

Pump Protector **DRN** series

Detects Unusual Pump Operating Conditions Including Dry-Running and Overload

The DRN model protects equipment (including pumps) from damage!
Minimizes production downtime.
Identifies possible causes of alarms so they can be investigated and addressed.



Multiple Input

Easy Operation

Bar Graph

Logging Capability

Communication

Clamp-Type Current Sensor for Ease of Installation

Two analog, one digital, one temperature input and one current input.

Equipped with EASY setup mode to remember the operation status and set the lower/upper limit values, as well as AUTO setup mode.

Visible indication of current operating status. (Refer to the figure below)

Data log feature for preventative maintenance scheduling.

RS485 external communication capability.

No modification of motor leads necessary.

Specifications

Model	DRN-01	DRN-02
Amperometric range	0.50 - 30.00A	5.0 - 200.0A
Unit's source voltage	AC100 - 240V 50/60Hz 10VA	
Operating temperature	0 - 40°C	
Operating humidity	35 - 85%RH	
Current sensor	JS10FL	JS24FL
Analog input 1	4 - 20mA or 1 - 5V	
Analog input 2	4 - 20mA or 1 - 5V	
Temperature range	-50 - 200°C (Pt100, K thermocouple)	
Digital contact input	No voltage contact signal (also for external reset)	
Contact output	For pre-alarm : AC250V 8A (load resistance) 1c For pump-stopping : AC250V 8A (load resistance) 1a	
Logging capability	Past records (with the calendar)	
Communication	RS485 incorporated	
Supported models	MX, MXM, SMX, MDM, MDE, MDW	
Dimension in mm	D71×W108×H90	

* Not used with inverter combination.

* Safety: CE/cETLus

UL 61010-1

CAN/CSA C22.2 No. 61010-1

LVD: EN61010-1

EMC: EN61326-1

RoHS: EN IEC63000

Example

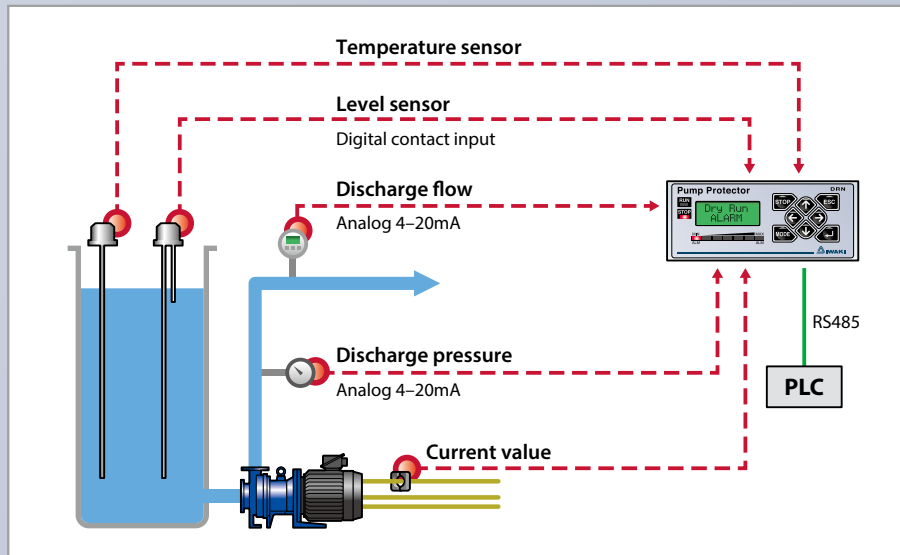



* For selection, use the rated current value of the pump-mounted motor as a standard.

IWAKI CO., LTD. 6-6 Kanda-Sudacho 2-chome Chiyoda-ku Tokyo 101-8558 Japan TEL : (81)3 3254 2935 FAX : 3 3252 8892 IWAKI has global net work. www.iwakupumps.jp

European Headquarter	IWAKI Europe GmbH	TEL: (49)2154 9254 0	FAX: (49)2154 9254 48	U.S.A.	IWAKI America Inc.	TEL: (1)508 429 1440	FAX: (1)508 429 1386
Germany	IWAKI Europe GmbH	TEL: (49)2154 9254 50	FAX: (49)2154 9254 55	Brazil	IWAKI Do Brasil Comercio De Bombas Hidraulicas LTDA.	TEL: (55)19 3244 5900	FAX: (55)19 3244 5900
The Netherlands (Netherlands Branch)	IWAKI Europe GmbH	TEL: (31)74 2420011	FAX: (49)2154 9254 48	China (Shanghai)	IWAKI Pumps (Shanghai) Co., Ltd.	TEL: (86)21 6272 7502	FAX: (86)21 6272 6929
Italy (Italy Branch)	IWAKI Europe GmbH	TEL: (39)0445 561219	FAX: (39)0445 569088	China (Hong Kong)	IWAKI Pumps Co., Ltd.	TEL: (852)2607 1168	FAX: (852)2607 1000
Spain (Spain Branch)	IWAKI Europe GmbH	TEL: (34)934 741 638	FAX: (34)934 741 638	China (Guangzhou)	GFTZ IWAKI Engineering & Trading Co., Ltd.	TEL: (86)20 84350603	FAX: (86)20 84359181
Poland (East Europe Branch)	IWAKI Europe GmbH	TEL: (48)12 347 0755	FAX: (48)12 347 0900	Singapore	IWAKI Singapore Pte Ltd.	TEL: (65)6316 2028	FAX: (65)6316 3221
Denmark	IWAKI Nordic A/S	TEL: (45)48 242345		Indonesia (Indonesia Office)	IWAKI Singapore Pte Ltd.	TEL: (62)21 6906606	FAX: (62) 21 6906612
Finland	IWAKI Suomi Oy	TEL: (358)10 201 0490		Malaysia	IWAKim SDN. BHD.	TEL: (60)3 7803 8807	FAX: (60)3 7803 4800
Norway	IWAKI Norge AS	TEL: (47)23 38 49 00		Korea	IWAKI Korea Co.,Ltd.	TEL: (82)2 6238 4800	FAX: (82)2 6238 4801
Sweden	IWAKI Sverige AB	TEL: (46)8 511 72900		Taiwan	IWAKI Pumps Taiwan Co., Ltd.	TEL: (886)2 8227 6900	FAX: (886)2 8227 6818
Belgium	IWAKI Belgium N.V.	TEL: (32)13 670200	FAX: (32)13 672030	Thailand	IWAKI (Thailand) Co.,Ltd.	TEL: (66)2 322 2471	FAX: (66)2 322 2477
France	IWAKI France S.A.	TEL: (33)1 69 63 33 70	FAX: (33)1 64 49 92 73	Australia	IWAKI Pumps Australia Pty Ltd.	TEL: (61)2 9899 2411	FAX: (61)2 9899 2421

() Country codes

 **Caution for safety use:** Before use of pump, read instruction manual carefully to use the product correctly. Actual pumps may differ from the photos. Specifications and dimensions are subject to change without prior notice. For further details please contact us.

 **Legal attention related to export.** Our products and/or parts of products fall in the category of goods contained in control list of international regime for export control. Please be reminded that export license could be required when products are exported due to export control regulations of countries. The posting and copying from this catalogue without permission is not accepted firmly.