

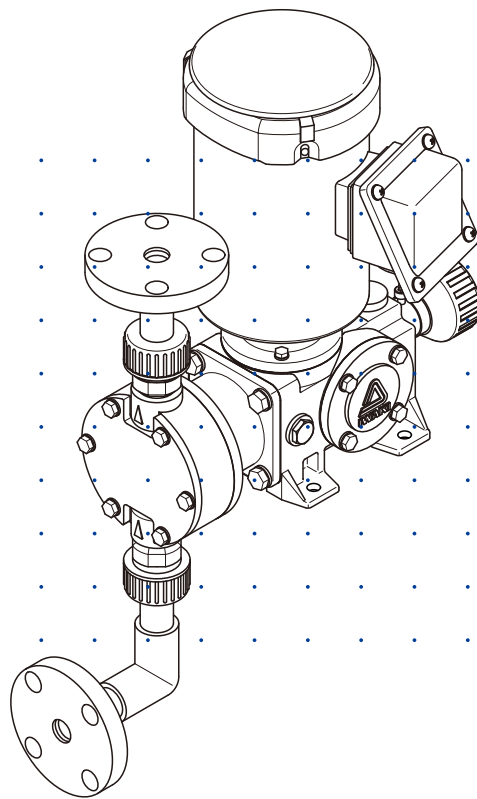

IWAKI Metering Pump LK



Instruction manual

Thank you for choosing our product.

 Please read through this instruction manual before use.

This instruction manual describes important precautions and instructions for the product. Always keep it on hand for quick reference.

Order confirmation

Open the package and check that the product conforms to your order. If any problem or inconsistency is found, immediately contact your distributor.

a. Check if the delivery is correct.

Check the nameplate to see if the information such as model codes, discharge capacity, discharge pressure and spm are as ordered.

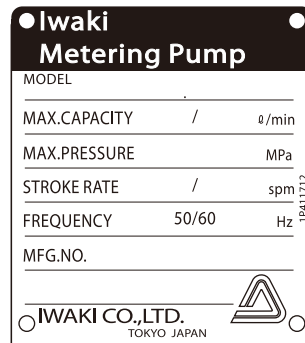

b. Check accessories are complete.

Check the table below to see if there is no missing part.

	Model	V6H/VCH/VSH	V6U/VCU	V6/VC/VS	S6
Standard	M8×25 bolts (×4)	✓	✓	✓	✓
	BVC-1P (×1)	✓	—	—	—
	4m braided tube (×1)	✓	—	—	—
	S-V4H or S-V12H (×1)	✓	—	—	—
Option	Pump base	Options are provided if requested.			
	Foundation bolts/nuts (×4)				

*The parenthesis value represents the number of parts attached to a pump.

*The BVC-1P is not attached to the LK-47.

*Unions or flange units are packed separately for all the V6U, VCU, V6, VC and VS types.

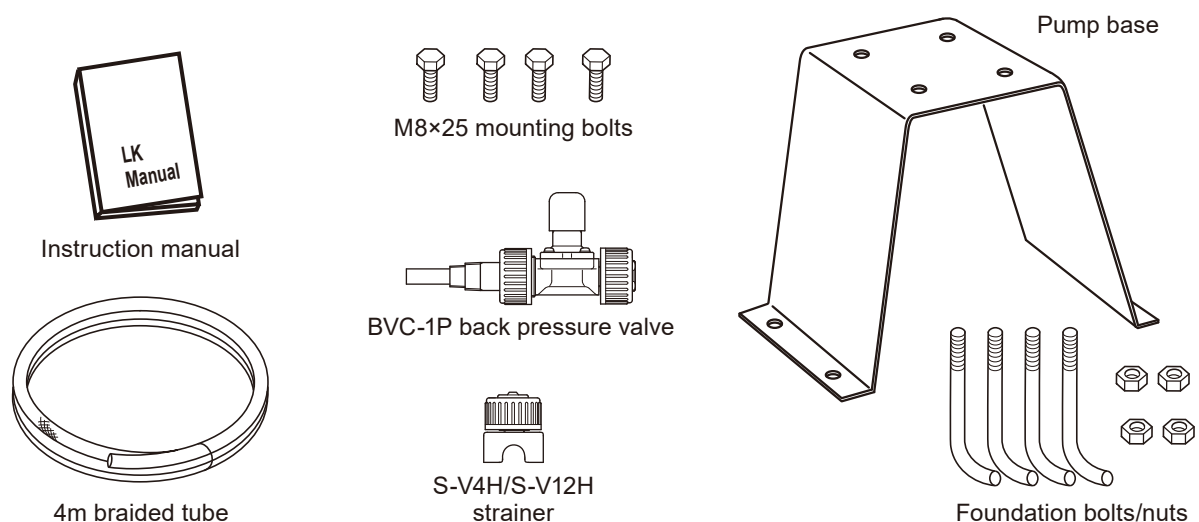

c. Check if the delivery is damaged or deformed.

Check for transit damage and loose bolts.

Contents

Order confirmation	2
Safety instructions.....	5
WARNINGS	6
CAUTIONS.....	8
Precautions for use	10
Overview.....	11
Introduction	11
Pump structure & Operating principle	11
Pump mechanism	12
Gear unit	12
Stroke length knob	12
Part names.....	13
Pump names	13
LK-32 (Flange connection & Baseplate)	13
Identification codes	14
Installation	15
Pump mounting.....	15
Necessary devices.....	16
Relief valve.....	16
Air chamber.....	16
Back pressure valve.....	16
Strainer.....	16
Pressure gauge.....	16
Before installation.....	16
Pipework	17
Pump system.....	17
Suction line.....	18
Discharge line	18
Flange/Tube/Union connection	18
Flange connection (LK-1/-2/-3).....	18
Flange connection (LK-4/-5)	19
Tube connection.....	20
Union connection	21
Wiring	22
Before wiring	22
Electrical motor	22

Operation..... 23

Before operation	23
Check procedure.....	24
Operation	25
Commissioning.....	25
Points to be checked.....	26
Operation	26
Stroke length adjustment	27
Before/After a long period of stoppage	28
Before a long period of stoppage.....	28
Resumption after stoppage.....	28

Maintenance..... 29

Troubleshooting.....	29
Inspection	32
Daily inspection.....	32
Periodic inspection.....	32
Gear oil replacement.....	33
Replacement procedure.....	33
Wear part replacement.....	34
Wear part list.....	35
Before replacement.....	35
Valve assembly	36
Disassembly.....	36
Assembly.....	37
Diaphragm.....	38
Disassembly.....	38
Assembly.....	39
Exploded view	41
Pump head.....	41
LK-11/-21/-22/-31/-32 V6H/VCH/VSH	41
LK-11/-21/-22/-31/-32 V6U/VCU/VSU.....	42
LK-11/-21/-22/-31/-32 V6/VC/VS	43
LK-45/-47/-55/-57 V6U/VCU/VSU	44
LK-45/-47 V6H/VCH & LK-45 VSH.....	45
LK-45/-47/-55/-57 V6/VC/VS	46
LK-11/-21/-22/-31/-32 S6	47
LK-45/-47/-55/-57 S6	48
Specifications/Outer dimensions.....	49
Specifications.....	49
Outer dimension.....	49

Safety instructions

Read through this section before use. This section describes important information for you to prevent personal injury or property damage.

■ Symbols

In this instruction manual, the degree of risk caused by incorrect use is noted with the following symbols. Please pay attention to the information associated with the symbols.

	WARNING	Indicates mishandling could lead to a fatal or serious accident.
---	----------------	--

	CAUTION	Indicates mishandling could lead to personal injury or property damage.
---	----------------	---

A symbol accompanies each precaution, suggesting the use of "Caution", "Prohibited actions" and specific "Requirement".

Caution marks	Prohibition mark	Requirement mark
 Caution  Electrical shock	 Prohibited  Do not rework or alter  Fire ban	 Requirement  Wear protection  Grounding

Export Restrictions

Technical information contained in this instruction manual might be treated as controlled technology in your countries, due to agreements in international regime for export control.

Please be reminded that export license/permission could be required when this manual is provided, due to export control regulations of your country.

⚠ WARNINGS



Requirement

Turn off power before service

Risk of electrical shock. Be sure to turn off power to stop the pump and related devices before service is performed.



Requirement

Stop operation

If you notice any abnormal or dangerous conditions, suspend operation immediately and inspect/solve problems.



Prohibited

Do not use the pump in any condition other than its intended purpose

The use of the pump in any conditions other than those clearly specified may result in failure or injury. Use this product in specified conditions only.



Do not remodel

Do not modify the pump

Alterations to the pump carries a high degree of risk. It is not the manufacturer's responsibility for any failure or injury resulting from alterations to the pump.



Wear protectors

Wear protective clothing

Always wear protective clothing such as an eye protection, chemical resistant gloves, a mask and a face shield during disassembly, assembly or maintenance work. The specific solution will dictate the degree of protection. Refer to SDS precautions from the solution supplier.



Prohibited

Stay out from under suspended loads

Risk of personal injury. Keep away from the pump while it is lifted up.



Prohibited

Do not damage the power cable

Do not pull, knot or crush the power cable. Damage to the power cable could lead to a fire or electrical shock if cut or broken.



Prohibited

Do not stand on the pump

Do not use the pump as a platform. Injury or damage may result when the pump turns over.

⚠ WARNINGS



Caution

Do not get access to the inside of the drive unit during operation

Risk of personal injury. A reciprocating diaphragm/shaft may catch the finger or hand.



Caution

Do not replace the motor fan cover in operation

Any rotating part may catch the hand, finger, hair, or clothes, and it may result in serious injury.



Requirement

Qualified personnel only

The pump should be handled or operated by qualified personnel with a full understanding of the pump. Any person not familiar with the product should not take part in the operation or management of the pump.



Requirement

Starting

The pump doesn't have an ON-OFF switch. The pump starts as a power cable is plugged in.



Prohibited

Closed-discharge operation is not allowed

Do not close a discharge line during operation. Otherwise, liquid leakage or pump-head/motor/piping breakage may result due to overpressure.

⚠ CAUTIONS



Requirement

Use specified power only

Do not apply power other than that specified on the nameplate. Otherwise, failure or fire may result. Ensure the pump is properly grounded.



Requirement

Ventilation

Fumes or vapours can be hazardous with certain solutions. Ensure proper ventilation at the operation site.



Prohibited

Do not install/store the pump:

- In a flammable/explosive/corrosive atmosphere.
- In a dusty/humid environment.
- Where ambient temperature can exceed 0-40°C.
- In direct sunlight or wind & rain.
- Under mechanical vibrations



Requirement

Spill precautions

Ensure protection and containment of solution in the event of plumbing or pump damage (secondary containment).



Caution

Do not touch the pump or pipe with bare hands

Risk of burning. The surface temperature of the pump or pipe rises high along with liquid temperature in or right after operation.



Fire ban

Do not bring the pump close to a flammable substance

Keep the pump away from a flammable substance for the prevention of fire. Do not allow a leak of lubricating oil. Observe local rules and regulations for handling of oils.



Grounding

Grounding

Risk of electrical shock! Always properly ground the pump. Conform to local electric codes.



Electrical shock

Install a GFCI (earth leakage breaker)

An electrical failure of the pump may adversely affect other devices on the same line. Purchase and install an earth leakage breaker separately.

⚠ CAUTIONS



Requirement

Foreign matter

When foreign matters enter the pump, turn off power at once and remove them. Using the pump with foreign matters may result in failure.



Requirement

Preventative maintenance

Follow instructions in this manual for replacement of wear parts. Do not disassemble the pump beyond the extent of the instructions.



Prohibited

Do not use a damaged pump

Using a damaged pump could lead to an electric leak or shock.



Requirement

Disposal of a used pump

Dispose of any used or damaged pump in accordance with local rules and regulations. If necessary, consult a licensed industrial waste disposal company.



Prohibited

Do not cover the pump with cloth

The motor temperature may build up and a fire or an electric/mechanical failure may result.



Requirement

Non freezing

Frozen liquid may damage the pump and piping. Drain liquid before leaving it for a long time or use measures to prevent liquid from freezing in winter.



Requirement

Pressure removal

Solution in the discharge line may be under pressure. Release the pressure from the discharge line before disconnecting plumbing or disassembly of the pump to avoid solution spray.



Caution

Use a proven chemically-resistant tube

The 4m PVC braided tube attached, for example, may be chemically attacked especially with sodium hypochlorite. Use a proven chemical resistant tube if an aggressive chemical is used.

Precautions for use

- Electrical work should be performed by a qualified electrician. Otherwise, personal injury or property damage may result.



- Do not install the pump:
 - A location that will hold liquid.
 - In a dusty place.
 - Where ambient temperature can exceed 40°C or falls below 0°C.
 - Where ambient humidity can exceed 90%RH.
 - Under mechanical vibration



- Allow sufficient space around the pump for easy access and maintenance.



- Use care handling the pump. Do not drop. An impact may affect pump performance. Do not use a pump that has been damaged to avoid the risk of electrical damage or shock.



- The pump is not waterproof. Do not operate the pump while wet with solution or water. Failure or injury may result. Immediately dry off the pump if it gets wet.



- Be careful not to get wet with a residual chemical as disconnecting piping or disassembling the pump.



- Do not clean the pump or nameplate with a solvent such as benzine and thinner. This may discolour the pump or erase printing. Use a dry or a damp cloth or a neutral detergent.



- Drain liquid before leaving it for a long time.



- Do not lay the pump on its side. Lubricant oil may leak from the gear box and wet the motor.



Overview

Pump characteristics, features and part names are described in this section.

Introduction

The LK series is mechanically-driven diaphragm pump. A wide selection range of wet ends allows for delivery of acid, alkaline, viscous liquid, slurry and solvent in various plants or built-in applications.

Pump structure & Operating principle

Motor rotation is transmitted to an worm wheel & shaft and then converted to the reciprocating motion of the pump shaft. Volumetric change occurs in the pump head as the diaphragm moves back and forth and liquid is pumped because of the suction and discharge check valves (ball valves).

Suction process

When the diaphragm moves back, negative pressure in the pump head closes the discharge check valve and open the suction check valve to take in liquid.

Discharge process

When the diaphragm moves forward, positive pressure in the pump head opens the discharge check valve and closes the suction check valve to deliver liquid.

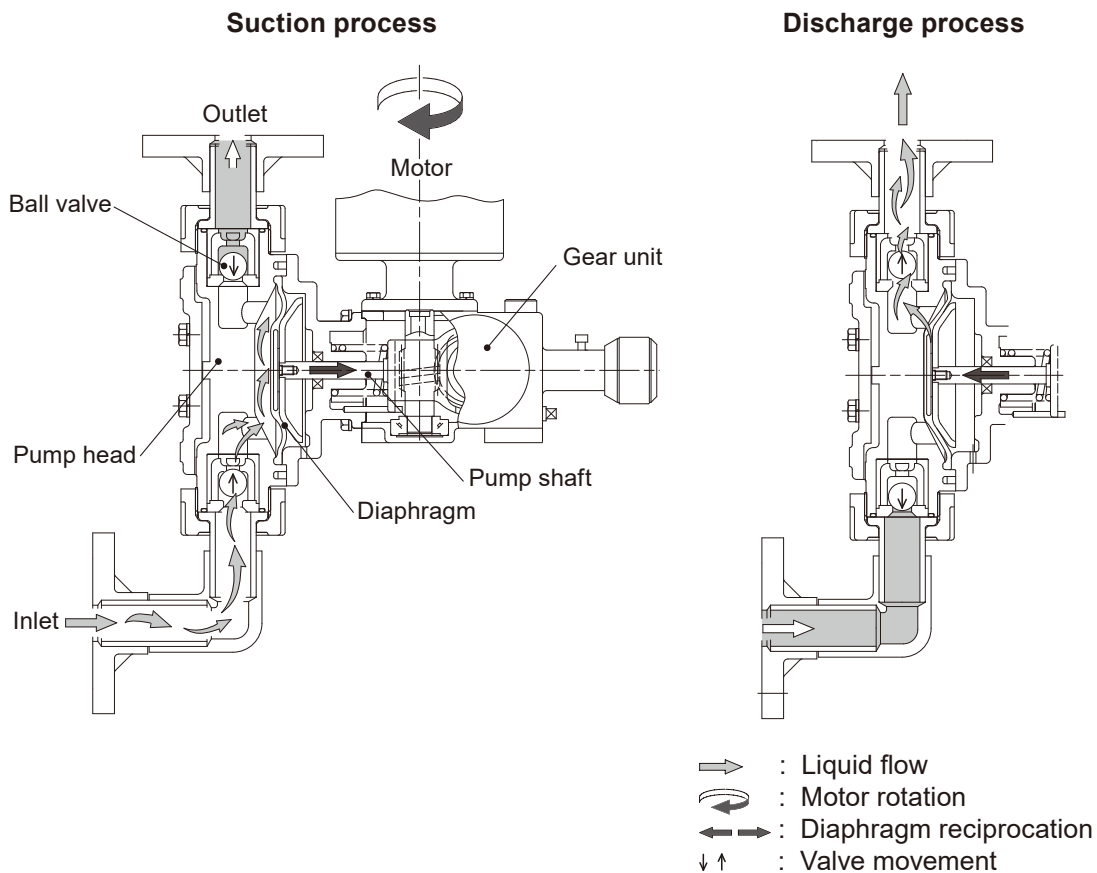

Pump mechanism

■ Gear unit

The gear unit of the LK is spring back design. Motor rotation is transmitted to a worm wheel & shaft and then converted to reciprocating motion of the pump shaft with the assistance of a slider and a spring.

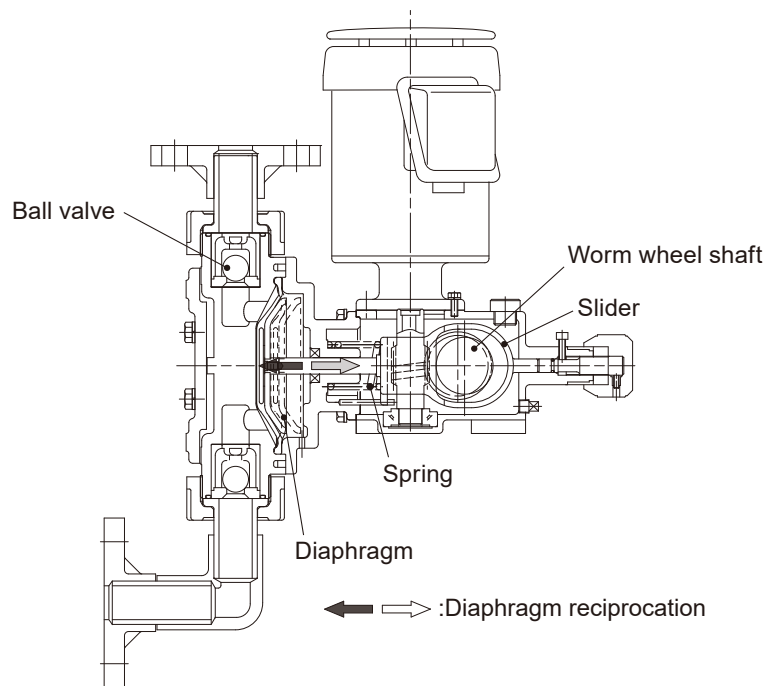

■ Stroke length knob

Use the SL knob at the end of the control shaft to determine a flow rate in between 0 and 100%, changing a slider position. See page 27 for detail.

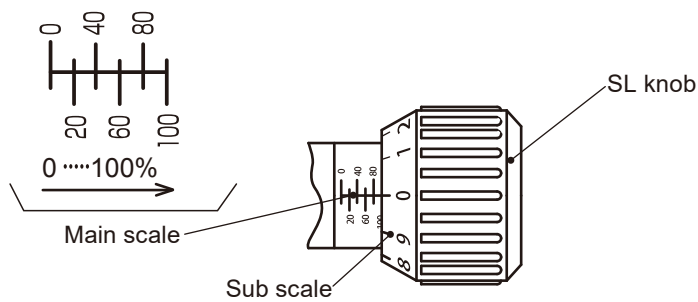

Part names

Pump

■ LK-32 (Flange connection & Baseplate)

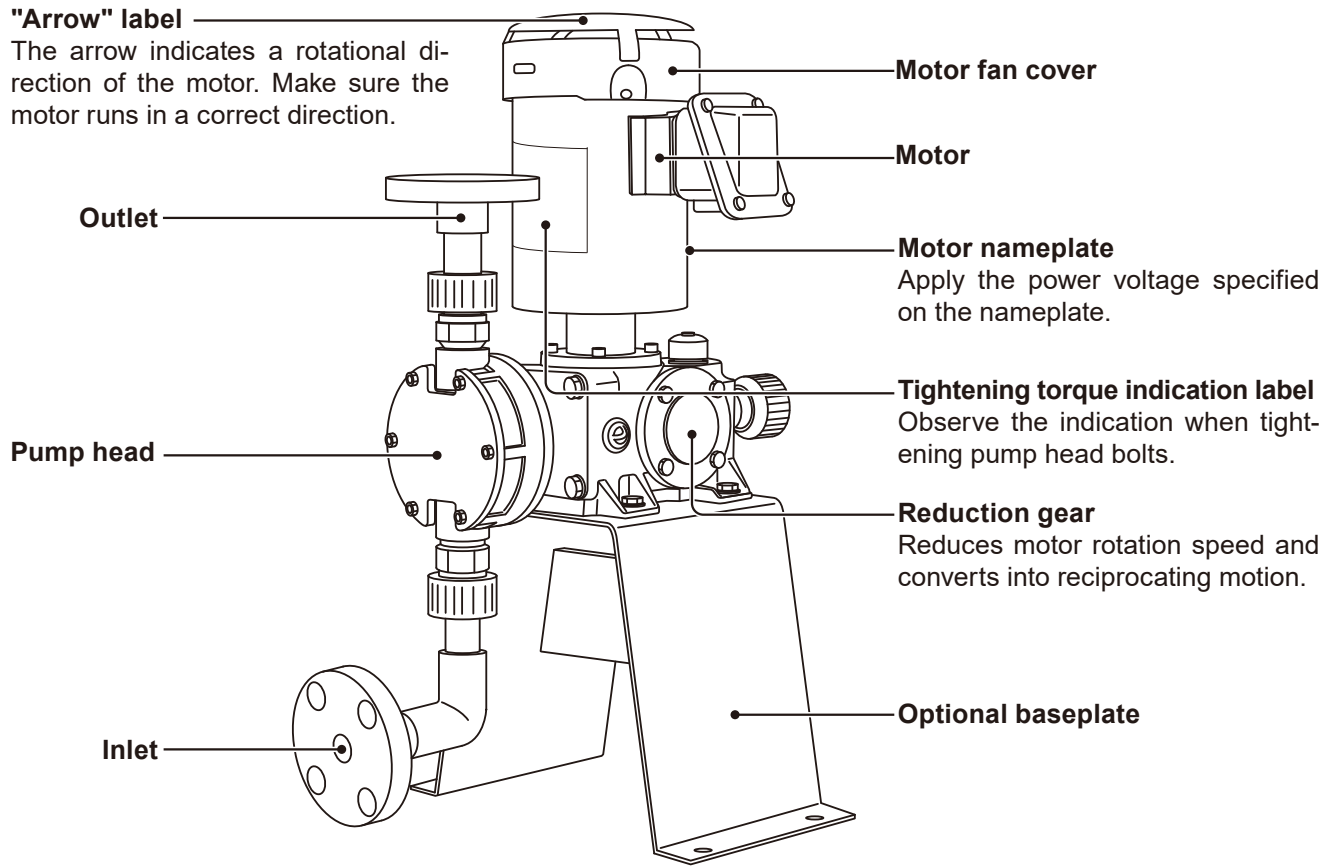

Stroke length knob
Determines liquid volume per shot in between 0 and 100%.

Pump nameplate
Operate the pump in accordance with specifications.

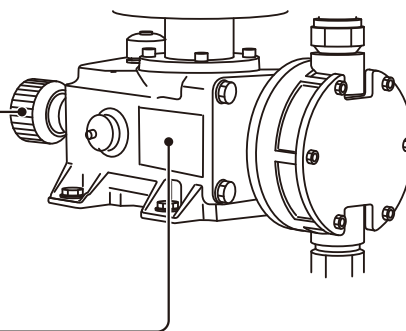

*Risk of fire or electric shock. Be sure to turn off power to stop the pump and related devices before inspection, maintenance and installation is performed.

*Keep the terminal box, motor fan cover and electric wiring dry.

*Do not clean nameplates, labels or pump body with a solvent.

Identification codes

Each code represents the following information.

2 LK - F 5 5 VC H - 02 F E S

a b c d e f g h i j k

a. Pump head

No code : Single head

2 : Twin head

b. Series name

LK : Mechanically-driven diaphragm pump

c. Drive unit

No code : 0.2/0.25kW dedicated motor

F : 0.4kW motor

d. Diaphragm size

1, 2, 3, 4, 5

e. Reduction gear ratio

1, 5 : 1/30 2, 7 : 1/15

f. Wet end materials

Code	Pump head	Diaphragm	Valve	Valve guide	Valve seat		O ring	Valve gasket
					LK-1/-2/-3	LK-4/-5		
V6	PVC	PTFE+ EPDM	SUS316 equivalent	PVC	EPDM	PVC	EPDM	PTFE
VC			Alumina ceramic		FKM		FKM	
VS			SUS316 equivalent		SUS304	SUS304	EPDM	
S6	SUS316	SUS316	SUS316	SUS316	SUS316	-		

Material code

SUS316 : Austenitic stainless steel

SUS304 : Austenitic stainless steel

PTFE : Polytetrafluoroethylene

PVC : Transparent polyvinyl chloride

EPDM : Ethylene-propylene rubber

FKM : Fluorine-contained rubber

g. Connection

No code : Flange U : Union H : Tube

h. Motors

02 : 0.2kW

03 : 0.25kW

04 : 0.4kW

i. Inverter

No code : No inverter (0.4kW motor) F : Inverter motor (0.2kW 3-phase motor)

j. Servo

No code : No servo unit

E : Servo unit

k. Special version

No code : Standard

S : Custom design

Installation

This section describes the installation of the pump, piping and wiring. Read through this section before work.

! Points to be observed

Observe the following points when installing the pump.

- Be sure to turn off power to stop the pump and related devices before service is performed.
- If you notice any abnormal or dangerous conditions, suspend operation immediately and inspect/solve problems.
- Do not place explosive or flammable material near the pump.
- Use of a damaged pump could lead to an electric shock or death.
- Use care handling the pump. Do not drop. An impact may affect pump performance. Keep the pump level when lifting it up.
- Fumes or vapours can be hazardous with certain solutions. Ensure proper ventilation at the operation site.
- Observe information on the appropriate drawing and specification sheet.

Pump mounting

Arrange pump and pipework based on the following piping layout for a long period of operation.

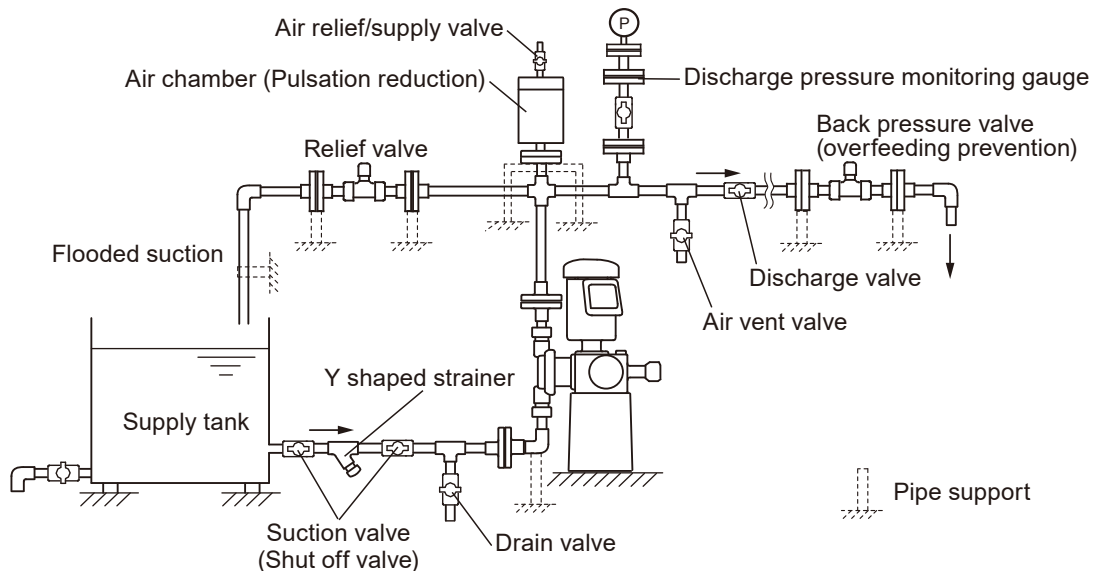

NOTE

- Design an efficient layout to meet NPSHr, especially when planning to deliver slurry.
- If pipework directory weighs on the pump, the pump may deform. Be sure to install pipe supports.

Necessary devices

The following devices are needed to the metering pump. Be sure to install, or personal injury or property damage may result.

■ Relief valve

The metering pump by nature keeps working, exceeding the limit pressure of discharge line if it is blocked. This may damage the pump/piping system and burn out the motor. Install a relief valve close to the pump and fix its set pressure below the maximum allowable pressure of the pump/discharge line.

■ Air chamber

Install an air chamber in order to reduce flow pulsation, piping vibration and overfeeding.

■ Back pressure valve

Discharge line pressure must be 0.03MPa or higher than suction line pressure. Otherwise, ball valve may not check flow and overfeeding may result. Install a back pressure valve on the discharge line to keep the minimum pressure difference as necessary.

■ Strainer

Provide a strainer at the end of a suction line for the prevention of foreign matter interfusion (Clean the strainer periodically.). Otherwise, clogging may result.

■ Pressure gauge

Install a pressure gauge to monitor the discharge line pressure.

Glossary

Overfeeding is the condition that check valves in the pump head stay open and liquid continues flowing into discharge line. Overfeeding occurs when the discharge line pressure is much lower than the suction line pressure.

Before installation

Check if installation doesn't adversely affect facility, surrounding equipment and the pump.

- Allow sufficient space around the pump for easy access and maintenance.
- Select a level location, free from vibration, that won't hold liquid. Always use a level gauge.
- Ensure protection and containment of solution in the event of plumbing or pump damage (secondary containment).
- Install the pump as close to a supply tank under flooded suction lift.

Pipework

Pipework must be done according to the following instructions to ensure the optimum performance, safety and service.

Pump system

- *Foreign matters such as sand and scale may enter pipework while service is performed. They may cause fatal damage to the pump. Be sure to blow them out before operation. Also, do not apply adhesive too much or leave a screw or nut.*
- *If pipework directly weighs on the pump, the pump may deform. Be sure to install pipe supports.*
- *Built an optimal piping system, taking account of the maximum pressure resistance and possible pressure drop. Always use a corrosion resistant pipe material.*
- *Have a suction line shortest with the minimum number of bends. Do not allow any arched line where air may be trapped.*
- *Install shutoff valves into both the suction and discharge lines for inspection and maintenance. Make sure that these valves are open during operation.*
- *Install a drain valve if it is possible for liquid in a discharge line to freeze.*
- *Connect the pump to pipework, fastening the flange tightening bolts evenly in diagonal order. No gap is allowed. Always use a rubber gasket in between flange connection.*
- *Flange connection must be free from any tension or distortion, or a leak or pipe damage may result.*
- *Use measures to keep the pump connections free from stress when two or more pumps are proximally positioned. Weight and thermal expansion/contraction of the piping can stress connection points.*
- *Do not allow any inverted arch line in pipework when handling slurry. Provide a drain port as necessary.*
- *Install a flushing line for cleaning the pump after handling a harmful liquid.*
- *If the pump is used to transfer a high or low-temperature liquid, install the flexible piping to protect the pump from the expansion and contraction of piping by thermal stress.*
- *Do not apply adhesive too much, especially when using a PVC discharge line.*
- *Flush the inside of the pump and piping with pure water or the liquid to be delivered before the start of operation. Inlet and outlet of some models are covered with a cap. Remove before installation.*

Suction line

1. The suction line I.D. should be equal to or wider than the I.D. of the pump so that NPSHr is satisfied.
2. Always keep the inlet of the pump below the liquid level of the supply tank (flooded suction). The maximum suction lift changes with pump size, operating conditions and liquid characteristics. Contact us for detail.
3. Joints of the suction line must be air tight. Otherwise output may be affected.
4. Foreign matters in the pump head may prevent check valve action. Install a strainer at the end of the suction line.

Discharge line

1. Install a relief valve on the discharge line, close to the pump. Do not install a gate valve in between the relief valve and the pump.
2. Install a pressure gauge on a discharge line for monitoring operating conditions.
3. The set pressure of the relief valve must not exceed the maximum allowable pressure of the discharge line.
4. Discharge line pressure must be 0.03MPa or higher than suction line pressure. Otherwise, ball valve may not check flow and overfeeding may result. Install a back pressure valve on the discharge line to keep the minimum pressure difference as necessary.

Flange/Tube/Union connection

■ Flange connection (LK-1/-2/-3)

- 1 Place O rings on the inlet and outlet adapters.
- 2 Set the flange units to the adapters and hand-tighten the nuts.
Observe the mounting directions of each part.

NOTE

Keep the O ring in place (an O ring groove) especially when tightening the suction flange unit.

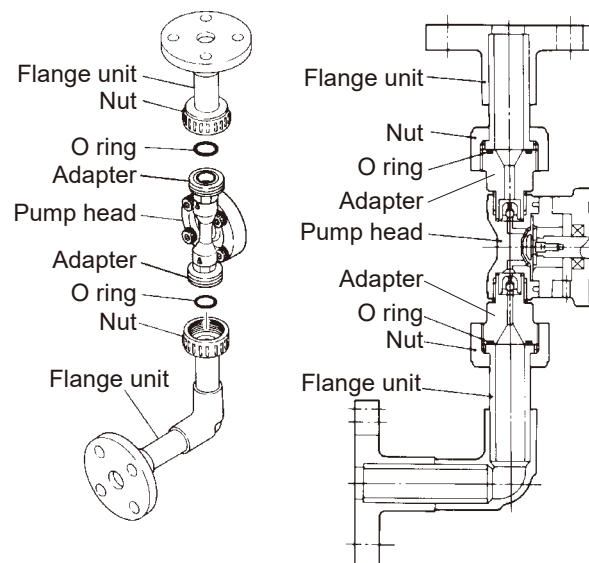

- 3 Use spanners to hold the adapters and hand-tighten the nuts.

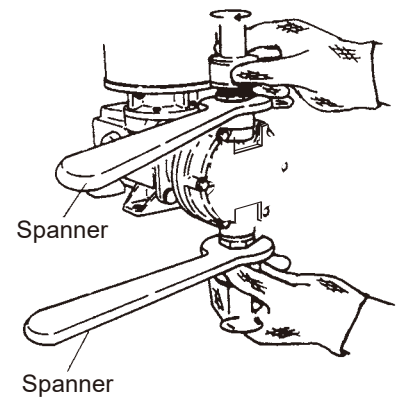

■ Flange connection (LK-4/-5)

- 1 Remove the caps from the pump head.

NOTE

Try not to drop the valve assembly from the inlet of the pump as removing the cap. See the diagram below to replace the assembly if it has dropped.

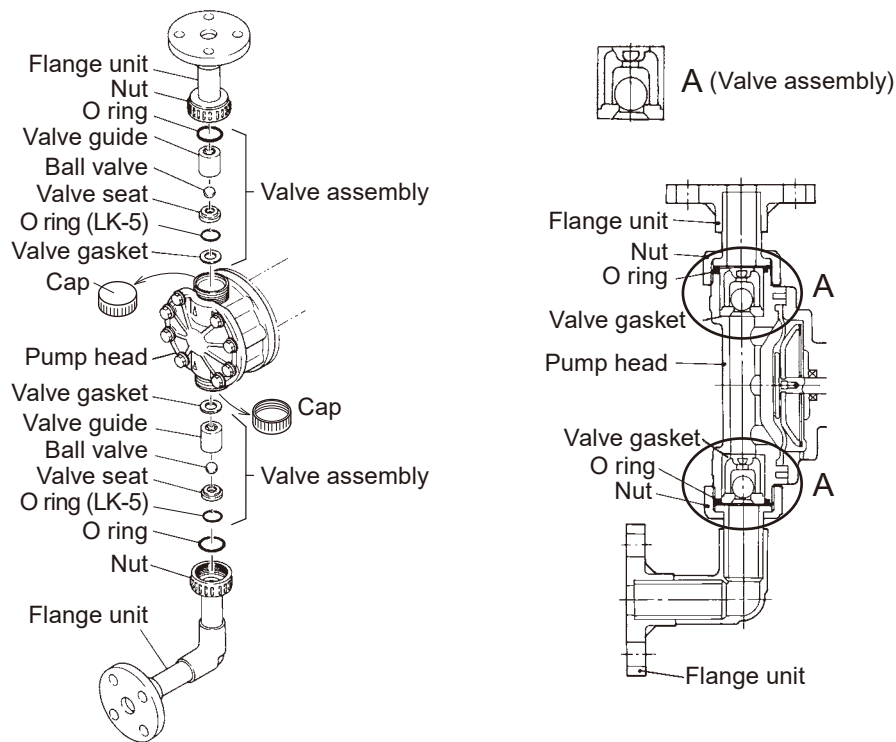

- 2 Place O rings on the inlet and outlet of the pump head.

- 3 Set the flange units to the pump head and hand-tighten the nuts.

Observe the mounting directions of each part.

NOTE

Keep the O ring in place (an O ring groove) especially when tightening the suction flange unit.

■ Tube connection

1 Cut the tube ends flat.

NOTE

A leak may result with uneven tube ends.

Tube end (Side view)



2 Pass a tube into the nut and ferrule and slide it down to the tube insert as far as it will go.

The tube end must come in at least 2mm from the bottom of the insert.

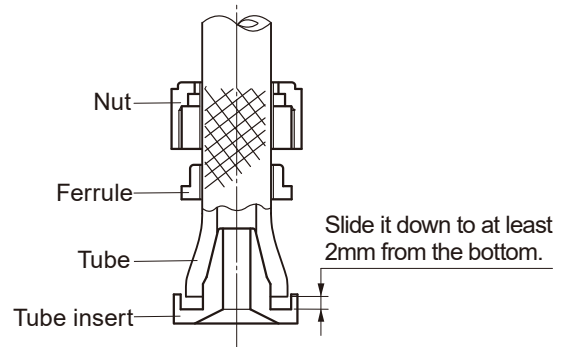

3 Place an O ring into the groove on the adapter, Hand-tighten the nut while holding the O ring with the tube insert.

NOTE

- The plastic nut may break. Do not use excessive force.
- The life of the attached braided tube changes with liquid characteristics and operating conditions.

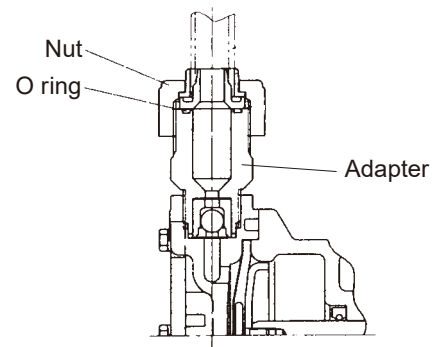

■ Union connection

The procedure of the union connection is almost the same as the Flange connection (LK-1/-2/-3) on page 18 or the Flange connection (LK-4/-5) on page 19. Follow either procedure depending on diaphragm size. Purchase flanges or sockets separately if needed. In this case, use an adhesive agent for the connection between those parts and the plastic union.

NOTE

Do not allow a drop of adhesive agent or sealant into pipework.

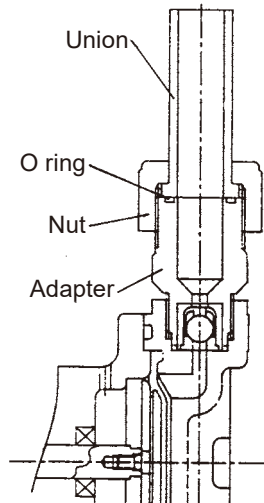

Wiring

Wiring for power voltage, earthing and external signals.

! Points to be observed

Observe the following points during wiring work.

- Electrical work should be performed by a qualified electrician. Always observe applicable codes or regulations.
- Do not perform wiring work while electric power is on. Otherwise, an electrical shock or a short circuit may result. Be sure to turn off the power before wiring work.
- Always use the recommended wiring accessories.
- Observe the specified power voltage on the nameplate of the motor. See motor manufacturer's instruction manuals for correct wiring.
- Do not remove the motor-fan cover while power is ON, any rotating part may catch the hand, finger, hair, or clothes, and it may result in serious injury.
- Risk of electrical shock! Always properly ground the pump. Conform to local electric codes.

Before wiring

Use peripheral devices as necessary. Observe the followings when each device is installed.

- Install an electromagnetic switch according to motor specifications (voltage, capacity, etc.).
- The pump and motor do not have protection equipment. Install an overcurrent protection or earth leakage breaker according to motor specification.
- Electromagnetic switches and push buttons should be installed away from the pump. Do not install them onto the pump or baseplate.
- If the pump is used out of doors, protect switches from rainwater.
- Install an ammeter into the pump system to monitor operating condition.

■ Electrical motor

Observe the rotational direction shown on the motor (positive rotation). 3-phase motors rotate positive when U, V and W motor terminals are connected in line with R, S and T power supply terminals. Start the motor for a second before operation and check the rotation is positive. Negative rotation will be a root cause of failure.

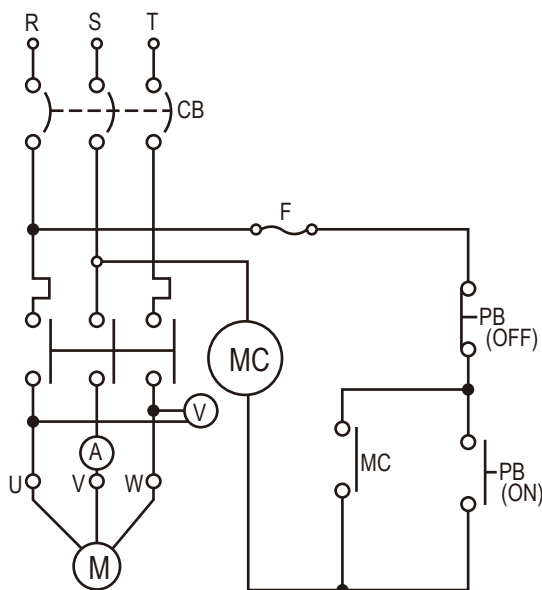

- M: Motor
- MC: Electromagnetic switch
- PB: Push button
- CB: Breaker
- V: Voltmeter
- A: Ammeter
- F: Fuse

Operation

This section describes general pump operation. Run the pump after pipe-work and wiring is completed.

Before operation

First check piping and wiring are correct. Make commissioning before starting operation.

! Points to be observed

Observe the following points during wiring work.

- This product should be handled or operated by qualified personnel with a full understanding. Any person not familiar with the product should not take part in the operation or maintenance of this product.
- Be sure to turn off all the related power supplies prior to any inspection/maintenance and installation works (motor fan cover). Working on the pump with power ON, any rotating part may catch the hand, finger, hair, or clothes, and it may result in serious injury.
- Risk of burning. Do not touch the pump or pipe with bare hands. The surface temperature of the pump or pipe rises high along with liquid temperature in or right after operation.
- Observe the motor rotational direction. Clockwise seen from the motor end is a correct direction. Operation in a reverse direction may cause pump damage.
- Do not close a discharge line during operation. Otherwise, liquid leakage or pump head/motor/piping breakage may result due to overpressure.
- Do not close a suction line during operation. Otherwise, internal parts are excessively worn by friction heat and fatal pump damage results.
- Do not make intermittent operation. Frequent ON-OFF operation damages internal parts of the pump and motor in a short time.

Check procedure

Operate the pump by the following procedure. Be sure to turn off main power.

- 1** Check for damage, loose bolts and an oil leak.
- 2** Observe the specified power voltage.
Check the nameplate of the motor.
- 3** Check if the motor is electrically-connected.
Electrical wiring must be correct. See the "Wiring" section on page 22 or motor manufacturer's instruction manuals.
- 4** Check for a liquid level in the supply tank and poor connections.
- 5** Check if the discharge and suction lines are laid correctly.
- 6** Check the oil gauge on the gear unit.
 - An oil level should be at the middle of the gauge (marked in red).
 - Remove the cap plug before operation (LK-F).

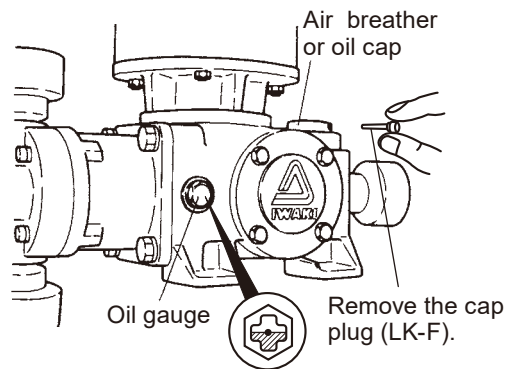

Operation

Read this section before operation.

Commissioning

Always make commissioning when first mounting the pump in your system or resuming operation after a long period of stoppage.

- 1** Open the suction and discharge valves.
- 2** Turn on motor power to run the pump.
- 3** Check the rotational direction of the motor.
Clockwise seen from the motor end (positive rotation) is the correct direction.
- 4** Set the stroke length to 0%.
See "Stroke length adjustment" on page 27 for detail.
- 5** Run the pump for 5 minutes with 0% stroke length and check for abnormality.
In cold climates, an electric current to the motor can double right after the start of operation. This overcurrent results when gear-oil temperature is too low. Run the pump with no discharge pressure until the oil warms up.
- 6** Expel air from the pump head.
Open an air vent line so that the discharge line is not pressurized. Increase the stroke length little by little until air is completely expelled.
- 7** Set the stroke length to 100% and run the pump for 30-60 minutes (running-in).
Check an electric current to the motor is rated value and no abnormality is found in your system. Keep the air vent line open during this time period.
- 8** Close the air vent line little by little and open a discharge line.
- 9** Use a calibration cylinder to measure discharge capacity.
Repeat measurement. The pump and system are ok when the measured discharge capacity does not change.
- 10** Determine the discharge capacity at every stroke rate and then meet the specified discharge capacity.
Test data with our piping system is available but try to determine how much discharge capacity is obtained at what stroke rate in your actual piping system.

NOTE

Observe the above instructions to keep the optimal operating conditions. If you notice any abnormal or dangerous conditions, suspend operation immediately and inspect/solve problems. See page 29 "Troubleshooting" or contact us.

Points to be checked

Check the following points during commissioning. If you notice any abnormal or dangerous conditions, suspend operation immediately and inspect/solve problems. See "Troubleshooting" on page 29 or contact us.

- Check a liquid level in the supply tank and discharge capacity.
- Check the suction and discharge pressure with a pressure gauge. They must not exceed the maximum pressure. See the nameplate for detail.

NOTE

- When the discharge capacity or discharge pressure falls down in operation, suspend operation immediately and check the pump and piping connections.
- Possibility of clogging or closed-discharge operation. Suspend operation immediately and remove problems when the discharge pressure rises sharply.

-
- Viscous liquid delivery with entrained air can be the root cause of noise or vibration.
 - Check pump/motor surface temperature during commissioning. Stop operation if it is extremely high.
 - A small gap in between pipe connections can entrain air and reduce discharge capacity. Secure every connections as necessary.
 - Liquid dissolves/reduces air volume in the air chamber. Periodically supply air to keep its performance.

NOTE

See manufacturer's manual for details of air chamber.

Operation

Start full operation in your system. Observe the above instructions to keep the optimal operating conditions. If you notice any abnormal or dangerous conditions, suspend operation immediately and inspect/solve problems. See page 29 "Troubleshooting" or contact us.

Stroke length adjustment

Use the stroke length knob to determine the liquid volume per stroke. Always make this adjustment while the pump is running.

NOTE

- The adjustment must be made while the pump is running.
- Do not rotate the knob beyond the max or min position. A flow rate does not change beyond these positions.

- 1 Loosen the hex socket head bolt.

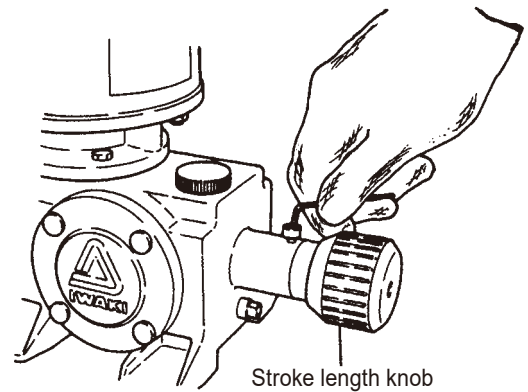

- 2 Run the pump in the system and measure discharge capacity with a calibration cylinder (at each stroke length).
Collect data to make a performance curve.

- 3 Determine the optimal stroke length to obtain the specified discharge capacity.
See the following diagrams at each diaphragm size to get a rough idea about proper knob rotation.

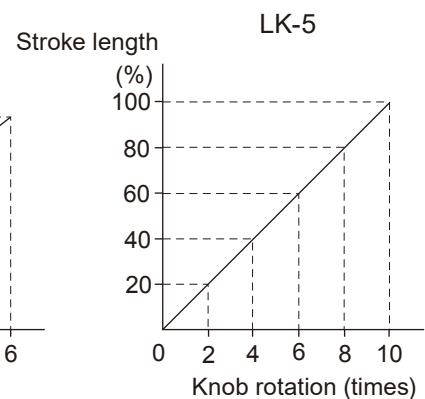
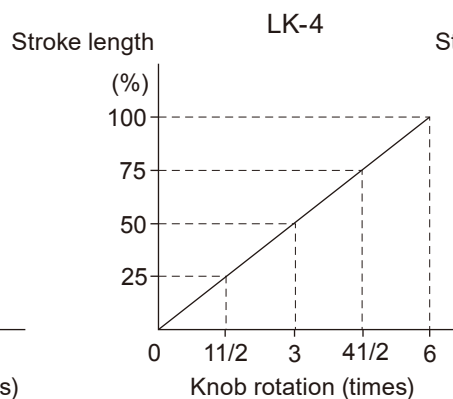
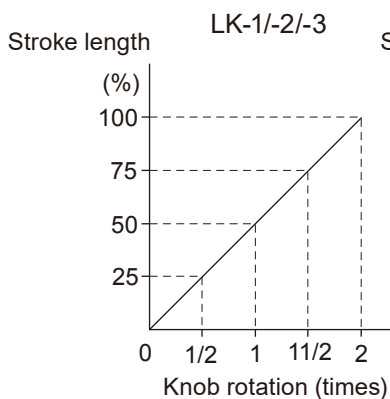
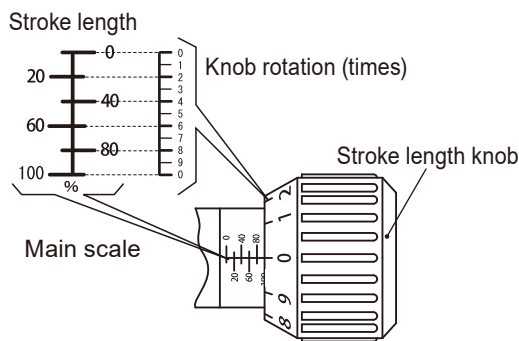

- 4 Tighten the hex socket head bolt to fix the length.

Before/After a long period of stoppage

■ Before a long period of stoppage

- Solution in the discharge line may be under pressure. Release the pressure from the discharge line before disconnecting plumbing or disassembly of the pump to avoid solution spray.
- Flush the inside of the pump and pipework with clean water or cleaning liquid.
- Frozen liquid may damage the pump and piping. Before leaving the pump stopped in cold climates, run the pump with the open drain valve to let out liquid, or temporarily use the band heater to keep the liquid in the pump and piping warm when suspending operation just for a short period of time.
- Set the stroke length to 100% in operation and then stop the motor. Open the motor fan cover and rotate the motor fan by hand until the diaphragm shaft is fully retracted (the lightest fan rotation is obtained at the full retraction; the SL knob becomes hard to rotate in between 90 and 100% as shortening the stroke length) in order to prevent the diaphragm deformation.
- Run the pump with zero discharge-line pressure for about 5 minutes every 3 months in order to keep the motor bearing lubricated.

■ Resumption after stoppage

- When operation is resumed after a short period of stoppage (within a week), the pump can start to run at any stroke length and discharge pressure. Do not forget to expel air before operation as necessary. See page 25.
- When operation is resumed after a long period of stoppage (a few weeks later), run the pump with 0% stroke length and zero discharge-line pressure for a few minutes to lubricate the internal parts in the drive unit before full operation.
- When operation is resumed after a long period of stoppage (a few months later), the flow rate may be too low to meet the specified discharge capacity due to diaphragm deformation. The diaphragm may recover its original shape after a few hours of running in.

Maintenance

This section describes troubleshooting, maintenance, wear part replacement, exploded views and specifications.

! Points to be observed

Observe the following points during maintenance work.

- Follow instructions in this manual for replacement of wear parts. Do not disassemble the pump beyond the extent of the instructions.
- Always wear protective clothing such as an eye protection, chemical resistant gloves, a mask and a face shield during dismantlement, assembly or maintenance work.
- Risk of electrical shock. Be sure to turn off power to stop the pump and related devices before service is performed.
- Working on the pump while power is ON and the motor fan cover is removed, any rotating part may catch the hand, finger, hair, or clothes, and may result in serious injury.
- Risk of burning. The surface temperature of the pump or pipe rises high along with liquid temperature in or right after operation. Do not touch the pump or pipe with bare hands.

Troubleshooting

First check the following points. If the following measures do not help remove problems, contact your nearest distributor.

States	Possible causes	Solutions
Motor does not starts to run.	Motor failure	Replace with new one.
	Disconnection	Reconnect motor wires or replace the motor.
	Power fuse has blown.	Inspect/solve the root cause of the blowout.
	Power voltage reduction	Inspect/solve the root cause of the reduction.
	Overpressure (discharge line)	Inspect/solve the root cause of the overpressure.
	Out of the rated voltage range	Inspect/solve the root cause of the abnormal power voltage.
Flow is too low.	NPSHr is not satisfied.	Review the pump and piping system to meet the NPSHr.
	Ball valve and valve seat have been worn.	Replace with new ones.
	Foreign matters in the ball valve	Take apart and clean the valve.
	Clogged suction line or strainer	Take apart and clean them.
	Stroke length knob is not set correct.	Set optimal stroke length.
	Stroke rate reduction	Check the power voltage, motor and gear unit.
	Overpressure (discharge line)	Inspect/solve the root cause of the overpressure.
	Air ingress from the suction line.	Check for loose connections and retighten as necessary.
	Different liquid is used.	Check liquid characteristics and pump specification.
	Pressure gauge has failed.	Replace with new one.
	Clogging in a pressure gauge	Remove clogging.
	A leak from a relief valve	Check the set pressure or secure connections.
	Damaged diaphragm	Replace with new one.

States	Possible causes	Solutions
Flow is too low.	Damaged valve gaskets or O rings	Replace with new ones.
	Entrained air in the pump head.	Perform degassing.
	Misarranged valve assembly	Rebuild in correct order.
Flow is too high.	Stroke length knob is not set correct.	Determine optimal stroke length.
	Minimal differential pressure is not kept and overfeeding results.	Keep the minimal differential pressure.
	Different liquid is used.	Check liquid characteristics and pump specification.
Flow fluctuates.	NPSHr is not satisfied.	Review the pump and piping system to meet the NPSHr..
	Ball valve and valve seat have been worn.	Replace with new ones.
	Foreign matters in the ball valve	Take apart and clean the valve.
	Clogged suction line or strainer	Take apart and clean them.
	Minimal differential pressure is not kept and overfeeding results.	Keep the minimal differential pressure.
	Stroke rate fluctuation	Check the power voltage, motor and gear unit.
	Air ingress from the suction line.	Check for loose connections and retighten as necessary.
	Different liquid is used.	Check liquid characteristics and pump specification.
	A leak from a relief valve	Check the set pressure or secure connections.
	Damaged valve gaskets or O rings	Replace with new ones.
	Entrained air in the pump head.	Perform degassing.
Motor overcurrent	Motor failure	Replace with new one.
	Disconnection	Reconnect motor wires or replace the motor.
	Power voltage reduction	Inspect/solve the root cause of the reduction.
	Foreign matters in the ball valve	Take apart and clean the valve.
	Clogged suction line or strainer	Take apart and clean them.
	Overpressure (discharge line)	Inspect/solve the root cause of the overpressure.
	Out of the rated voltage range	Inspect/solve the root cause of the abnormal power voltage.
	Different liquid is used.	Check liquid characteristics and pump specification.
	Oil level, grade or quality is wrong.	Check if it is proper. Replace as necessary.
No discharge	NPSHr is not satisfied.	Review the pump and piping system to meet the NPSHr.
	Ball valve and valve seat have been worn.	Replace with new ones.
	Foreign matters in the ball valve	Take apart and clean the valve.
	Clogged suction line or strainer	Take apart and clean them.
	Air ingress from the suction line.	Check for loose connections and retighten as necessary.
	Different liquid is used.	Check liquid characteristics and pump specification.
	A leak from a relief valve	Check the set pressure or secure connections.
	Damaged diaphragm	Replace with new one.
	Entrained air in the pump head.	Perform degassing.
	Misarranged valve assembly	Rebuild it in correct order.
Discharge pressure is too low.	NPSHr is not satisfied.	Review the pump and piping system to meet the NPSHr.
	Ball valve and valve seat have been worn.	Replace with new ones.

States	Possible causes	Solutions
Discharge pressure is too low.	Foreign matters in the ball valve	Take apart and clean the valve.
	Clogged suction line or strainer	Take apart and clean them.
	Air ingress from the suction line.	Check for loose connections and retighten as necessary.
	Different liquid is used.	Check liquid characteristics and pump specification.
	Pressure gauge has failed.	Replace with new one.
	Clogging in a pressure gauge	Remove clogging.
	A leak from a relief valve	Check the set pressure or secure connections.
	Damaged diaphragm	Replace with new one.
	Entrained air in the pump head.	Perform degassing.
	Misarranged valve assembly	Rebuild it in correct order.
Liquid leaks.	Clogged suction line or strainer	Take apart and clean them.
	Overpressure (discharge line)	Inspect/solve the root cause of the overpressure.
	Different liquid is used.	Check liquid characteristics and pump specification.
	Damaged diaphragm	Replace with new one.
	Damaged valve gaskets or O rings	Replace with new ones.
	Misarranged valve assembly	Rebuild it in correct order.
	Loose connection of the inlet and outlet	Tighten them as necessary.
	Loose pump-head-fixing-bolts	Tighten them as necessary.
A noise level is too high.	Motor failure	Replace with new one.
	NPSHr is not satisfied.	Review the pump and piping system to meet the NPSHr.
	Ball valve and valve seat have been worn.	Replace with new ones.
	Foreign matters in the ball valve	Take apart and clean the valve.
	Clogged suction line or strainer	Take apart and clean them.
	Overpressure (discharge line)	Inspect/solve the root cause of the overpressure.
	Oil level, grade or quality is wrong.	Check if it is proper. Replace as necessary.
	Misarranged valve assembly	Rebuild it in correct order.
Oil leaks.	Damaged gaskets or O rings	Replace with new ones.
No suction	NPSHr is not satisfied.	Review the pump and piping system to meet the NPSHr.
	Ball valve and valve seat have been worn.	Replace with new ones.
	Foreign matters in the ball valve	Take apart and clean the valve.
	Clogged suction line or strainer	Take apart and clean them.
	Air ingress from the suction line.	Check for loose connections and retighten as necessary.
	Damaged diaphragm	Replace with new one.
	Damaged valve gaskets or O rings	Replace with new ones.
	Entrained air in the pump head.	Perform degassing.
	Misarranged valve assembly	Rebuild it in correct order.
Gear unit temperature is too high.	Overpressure (discharge line)	Inspect/solve the root cause of the overpressure.
	Oil level, grade or quality is wrong.	Check if it is proper. Replace as necessary.

Inspection

Perform daily and periodic inspection to keep pump performance and safety.

Daily inspection

Check the following points. Upon sensing abnormality, stop operation immediately and remove problems according to "Troubleshooting".

When wear parts come to the life limit, replace them with new ones. Contact your distributor for detail.

No.	States	Points to be checked	How to check
1	Noise and vibration	• If abnormal noise or vibration occurs. They are signs of abnormal operation.	Visual or audio inspection
2	Air ingress from pump head joints and a suction line	• If leakage occurs.	Visual or audio inspection
3	Pressure gauge/Flow meter/ammeter	• If discharge pressure/capacity and a motor current value are normal.	Spec labels on the pump and the motor
4	Oil gauge on the gear unit.	• If an oil level is proper and oil is not deteriorated.	Visual
5	Spare pump condition	• If it is usable. Run it from time to time to keep it ready for operation at any time when needed.	Visual or audio inspection

Periodic inspection

Check wear parts such as valve set (a ball valve, valve guide, valve seat and valve gasket (or O ring)), diaphragm and tubing for heavy damage or wear at least every 6 months.

Part names	Points to be checked	Measures
Ball valve, valve guide, valve seat, valve gasket (or O ring)	If they are damaged or worn.	• Replace if pump performance has reduced. Note their lives change with operating conditions such as liquid characteristics and operating pressure.
Diaphragm	If it is damaged or worn.	• Replace if pump performance has reduced. Note diaphragm life changes with operating conditions such as liquid characteristics and operating pressure.
Tubing	If it is hardened or discoloured by ultraviolet-ray or chemical liquid. If it is deformed by high pressure.	• Replace if worn excessively. Note tubing life changes with operating conditions such as liquid characteristics and operating pressure.

NOTE

Check pump head connections for a leak. Tighten loose connections to the specified torque (see the spec label) or replace parts in question as necessary.

Gear oil replacement

Replace the reduction gear oil at the following intervals to keep pump performance.

- Running-in period: after 500 hours
- Operation period: every 2000-3000 hours
- Specified oil level is as follows:
 - Single head type: 220mL
 - Twin head type: 500mL
- Recommended oil is:

Oil company	Product name
Exxon Mobil Corporation	Mobilgear 600XP220

! Points to be observed

Observe the following points during maintenance work.

- Always wear protective clothing such as an eye protection, chemical resistant gloves, a mask and a face shield.
- Keep good ventilation in a storage area. Do not store oil in a flammable atmosphere or high temperature. Conform to local codes.

■ Replacement procedure

- 1 Loosen the drain plug and release old oil.

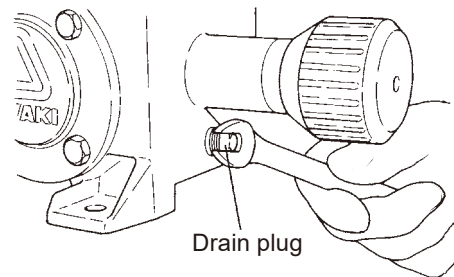

- 2 Pour flushing oil through the oil fill opening and rinse the inside of the gear unit.

- 3 Repeat rinsing a few times.

- 4 Drain flushing oil and pour new gear oil through the opening until it comes to the middle of the oil gauge (marked in red).

Wear part replacement

To run the pump for a long period, wear parts need to be replaced periodically. It is recommended that the following parts are always stocked for immediate replacement. Contact your distributor with the following information for wear part replacement.

1. Part names and part number (See "**Exploded view**" on page 41.)
2. Pump model identification code and manufacturing number (See pump nameplate.)
3. Drawing number if you have our approval drawing

! Precautions

- When dismantling the pump, pay attention to the residual liquid in the pump head.
- Follow instructions in this manual for replacement of wear parts. Do not disassemble the pump beyond the extent of the instructions.
- Always see the Exploded view section to check mounting directions of each parts.
- Use care handling the pump. Do not drop. An impact may affect pump performance. Keep the pump level when lifting it up.
- Rinse wet ends thoroughly with tap water in advance.
- Risk of electrical shock. Be sure to turn off power to stop the pump and related devices before service is performed.
- Solution in the discharge line may be under pressure. Release the pressure from the discharge line before disconnecting plumbing or disassembly of the pump to avoid solution spray.

Wear part list

Part names	Q'ty	Estimated life* ³
Ball valve	2	1 year
Valve guide	2	1 year
Valve seat	2	1 year
O ring (V6/VC/VS)* ¹		
LK-1/-2/-3	4* ² (2 types)	1 year
LK-4 flange/union connection	2	1 year
LK-4 tube connection	4* ² (2 types)	1 year
LK-5	4* ² (2 types)	1 year
Valve gasket		
V6/VC/VS	2	1 year
LK-1/-2/-3 S6	6* ² (2 types)	1 year
LK-4/-5 S6	6	1 year
Diaphragm	1	4000 hours

*¹See page 41-46 for the O ring size.

*²The value represents the total quantity of the O rings or valve gaskets attached to a pump.

*³Wear part duration varies with the pressure, temperature and characteristics of liquid.

Before replacement

Take the following steps before disassembly of the pump.

- 1** Turn off power and stop pump operation
- 2** Close the suction and discharge lines.
- 3** Release the suction and discharge line pressure.
- 4** Flush the inside of the pump head with tap water.

Valve assembly

■ Disassembly

NOTE

When dismantling the pump, pay attention to the residual liquid in the pump head.

1 Remove the discharge and suction lines from the pump.

2 Remove the nuts that are fixing the flange unit.

LK-V6/-VC/-VS

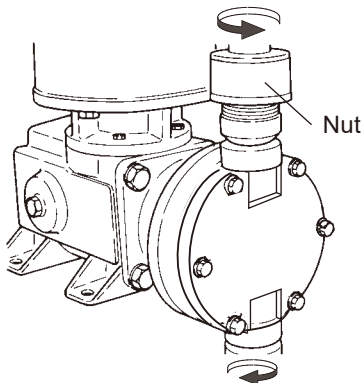

LK-S6

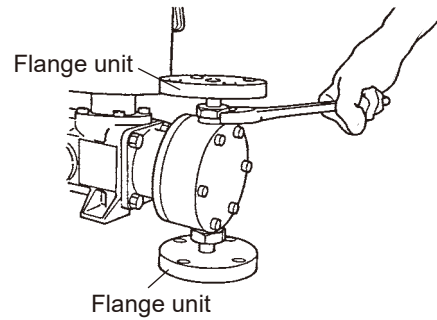

3 Take out the valve assembly.

NOTE

The valve assemblies may be stuck in the pump head. Be careful not to drop when removing the suction flange unit.

LK-V6/-VC/-VS

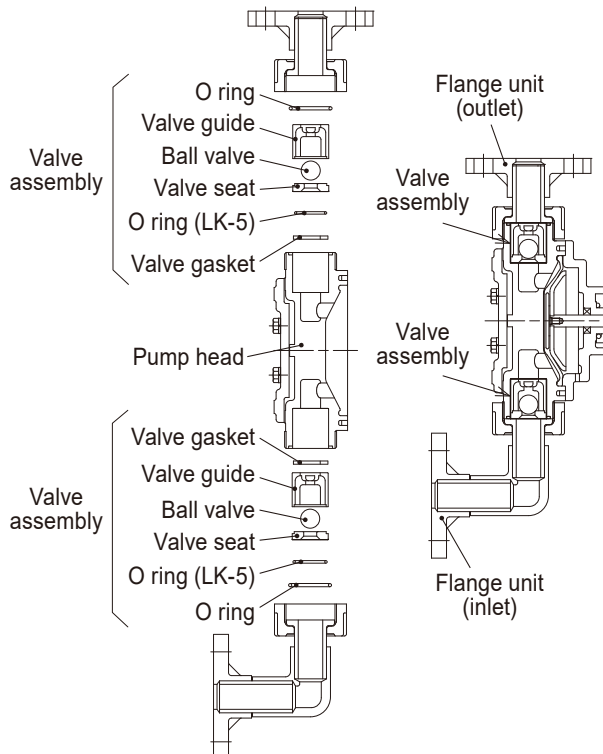

LK-S6

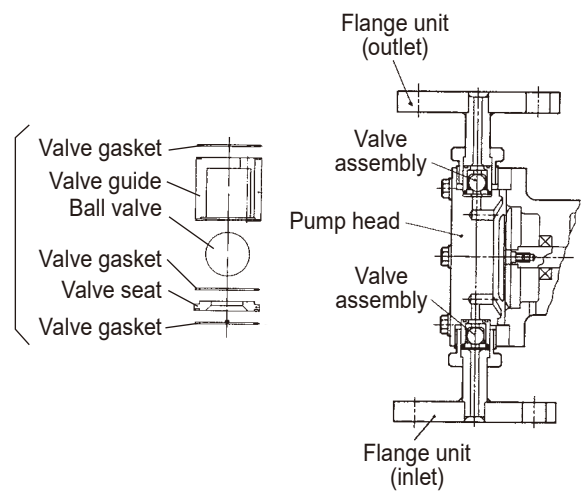

■ Assembly

1 Mount the valve assemblies.

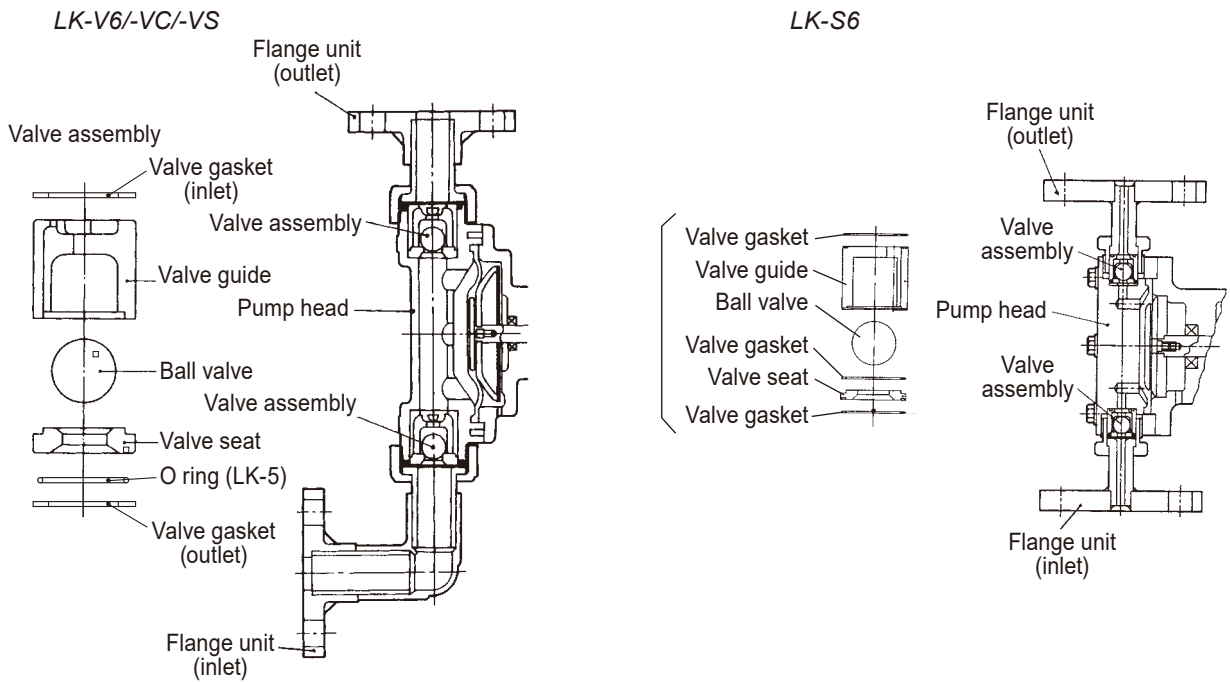

NOTE

Observe the mounting direction of the valve guide, ball valve, valve seat and valve gasket. Otherwise, a backflow, overpressure and motor/piping damage may result.

2 Place both the assemblies in the inlet and the outlet of the pump head.

NOTE

Be sure to place an O ring before tightening the flange units.

3 Connect the discharge line to the outlet and the suction line to the inlet via a flange gasket.

Do not allow any gap between flange connections.

NOTE

- Use measures to keep the flange connections free from stress. Do not allow any gap in a connected surface.
- Always fasten the flange bolts to the same torque in diagonal order.

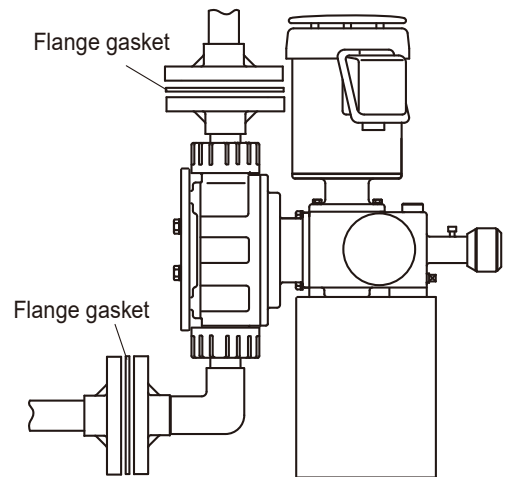
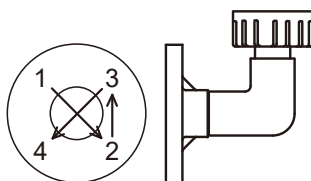

Diaphragm

■ Disassembly

1 Remove the discharge and suction lines from the pump.

2 Remove the related bolts and take out the reinforcing plate and pump head.

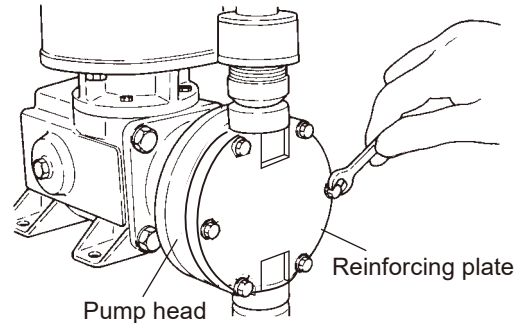

3 Remove three related screws on the motor fan cover to take the cover out.

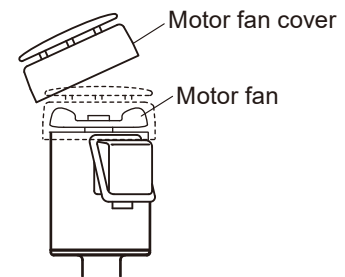

4 Rotate the motor fan by the hand to extend the pump shaft to the full.

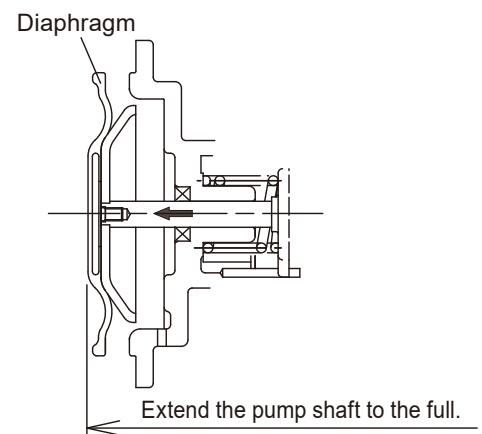

5 Rotate the diaphragm anticlockwise and remove it together with the retainer.

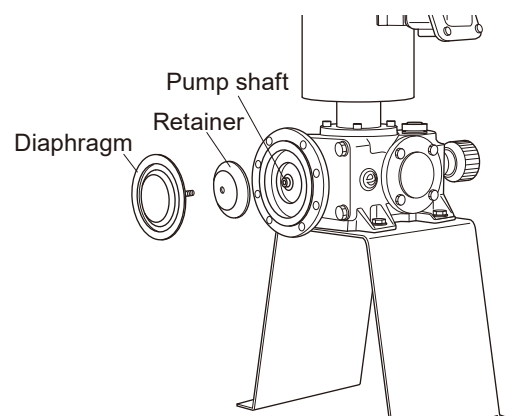

■ Assembly

- 1 Check that the pump shaft is extended to the full.

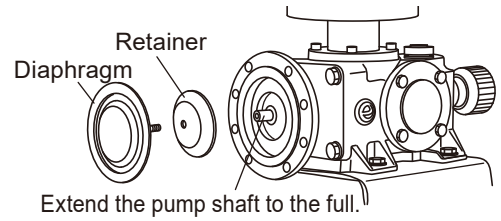

- 2 Fit the retainer onto the diaphragm shaft and screw the diaphragm into the pump shaft until it bottoms out and will not turn further.

Be sure to push down the retainer as far as it will go so as not to interfere with the diaphragm mounting.

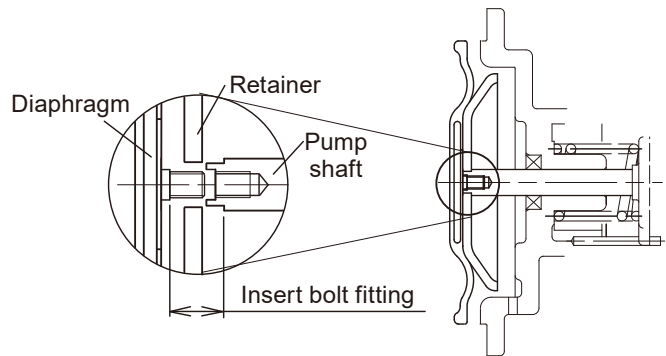
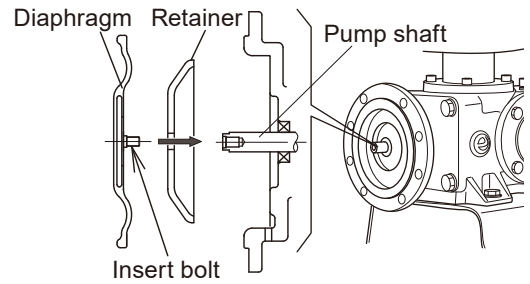

- 3 Use the stroke length knob to set the stroke length to 100%.

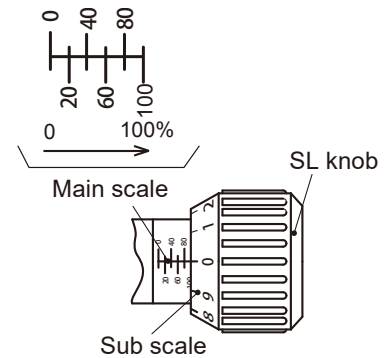

- 4 Rotate the motor fan by the hand to retract the diaphragm to the full.

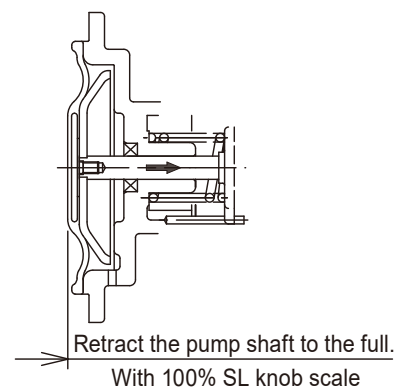

5 Mount the pump head and reinforcing plate with bolts.

Tighten the bolts in diagonal order to the specified torque below.

Model	Tightening torque
LK-1 V6/VC/VS/S6	2.2N•m
LK-2 V6/VC/VS/S6	2.9N•m
LK-3 V6/VC/VS	2.9N•m
LK-3 S6	4.9N•m
LK-4 V6/VC/VS/S6	11.8N•m
LK-5 V6/VC/VS/S6	11.8N•m

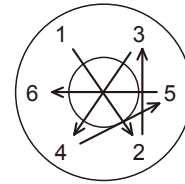
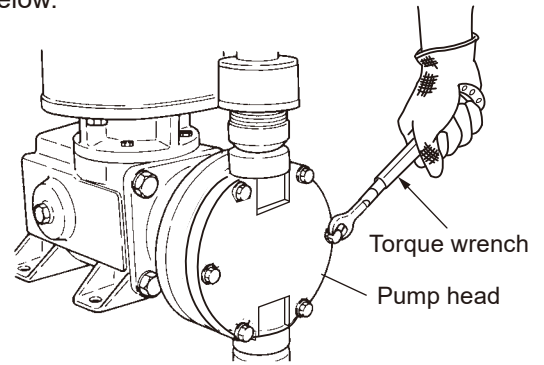

6 Fit and tighten the motor fan cover with the three screws.

7 Connect the suction and the discharge lines to the inlet and the outlet flange over the gasket.

NOTE

- Use measures to keep the flange connections free from stress. Do not allow any gap in a connected surface.
- Always fasten the flange bolts to the same torque in diagonal order.

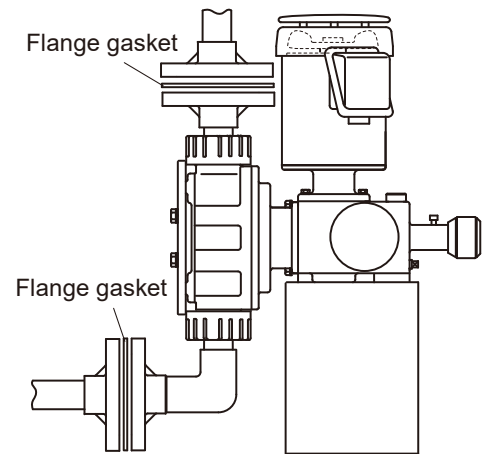
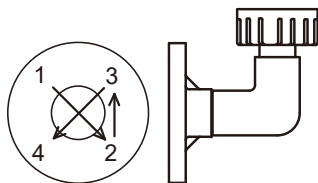

Exploded view

Pump head

■ LK-11/-21/-22/-31/-32 V6H/VCH/VSH

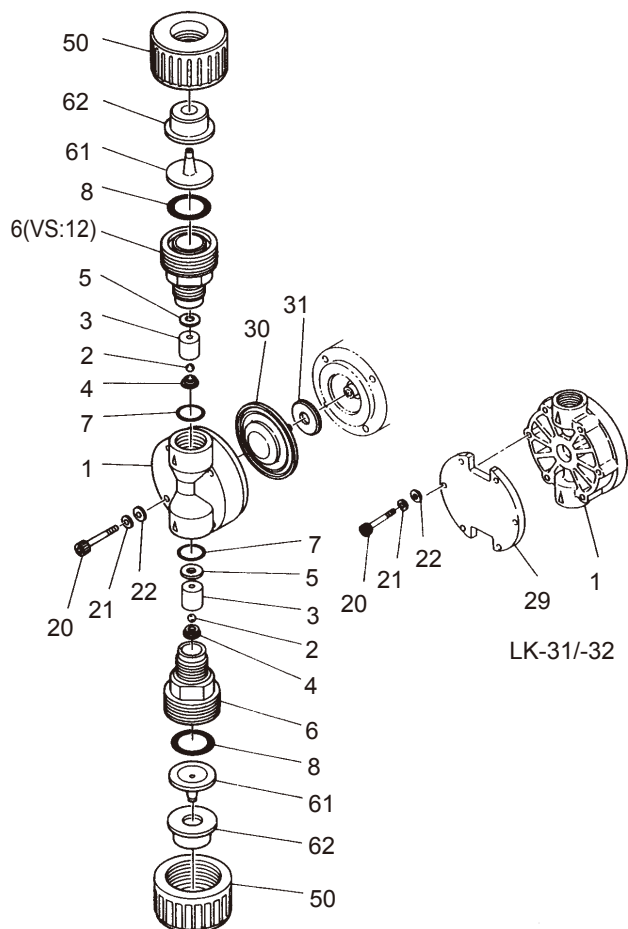

No.	Part names	# of parts	Materials			Remarks
			V6H	VCH	VSH	
1	Pump head	1	PVC			
2	Valve	2	SUS316 equivalent	Ceramic	SUS316 equivalent	
3	Valve guide	2	PVC			
4	Valve seat	2	EPDM	FKM	SUS304	
5	Valve gasket	2	PTFE			
6	Adapter	2	PVC			One for VS
7	O ring	2	EPDM	FKM	EPDM	S14/ P16*1
8	O ring	2	EPDM	FKM	EPDM	P20
12	Fitting	1	PVC			VS
20	Hex sock head bolt/ Hexagon bolts*2	4*3 (6)	Stainless steel			M4×35/ M5×30/ M5×45*4
21	Spring washer	4*3 (6)	Stainless steel			M4/M5*5
22	Plate washer	4*3 (6)	Stainless steel			M4/M5*5
29	Reinforcing plate	1	SS400			LK-31/ -32
30	Diaphragm	1	PTFE/EPDM			
31	Retainer plate	1	SUS304			
50	Nut	2	PVC			
61	Tube insert	2	PVC			
62	Ferrule	2	SS400			

- *1 LK-11/-21/-22: S14 O ring
LK-31/-32: P16 O ring
- *2 LK-11/-21/-22: Hex socket head bolt
LK-31/-32: Hexagon bolts
- *3 LK-11/-21/-22: 4 pieces each
LK-31/-32: 6 pieces each
- *4 LK-11: M4×35
LK-21/-22: M5×30
LK-31/-32: M5×45
- *5 LK-11: M4
LK-21/-22/-31/-32: M5

■ LK-11/-21/-22/-31/-32 V6U/VCU/VSU

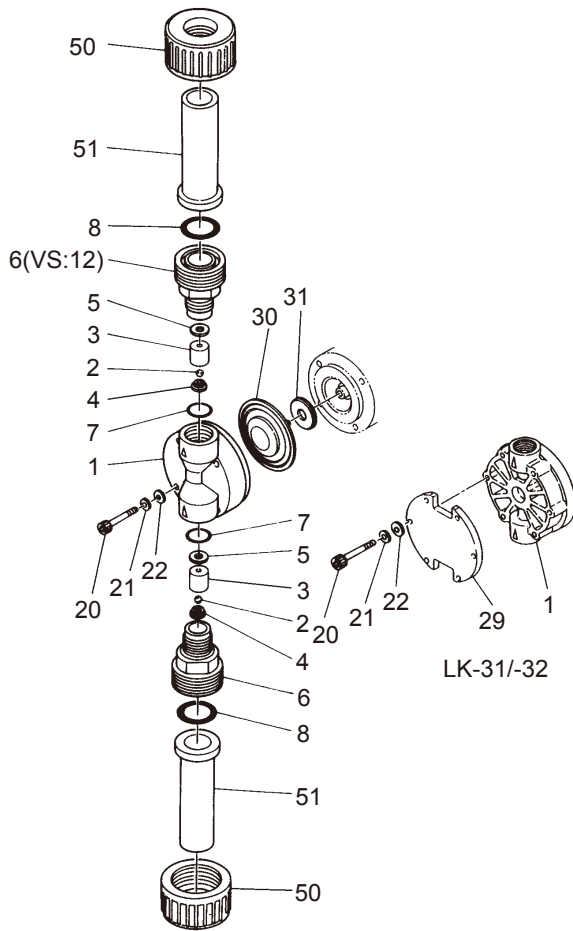

No.	Part names	# of parts	Materials			Remarks
			V6U	VCU	VSU	
1	Pump head	1	PVC			
2	Valve	2	SUS316 equivalent	Ceramic	SUS316 equivalent	
3	Valve guide	2	PVC			
4	Valve seat	2	EPDM	FKM	SUS304	
5	Valve gasket	2	PTFE			
6	Adapter	2	PVC			One for VS
7	O ring	2	EPDM	FKM	EPDM	S14/P16*1
8	O ring	2	EPDM	FKM	EPDM	P20
12	Fitting	1	PVC			VS
20	Hex socket head bolt/ Hexagon bolts*2	4*3 (6)	Stainless steel			M4×35/ M5×30/ M5×45*4
21	Spring washer	4*3 (6)	Stainless steel			M4/M5*5
22	Plate washer	4*3 (6)	Stainless steel			M4/M5*5
29	Reinforcing plate	1	SS400			LK-31/ -32
30	Diaphragm	1	PTFE/EPDM			
31	Retainer plate	1	SUS304			
50	Nut	2	PVC			
51	Union	2	PVC			

- *1 LK-11/-21/-22: S14 O ring
LK-31/-32: P16 O ring
- *2 LK-11/-21/-22: Hex socket head bolt
LK-31/-32: Hexagon bolts
- *3 LK-11/-21/-22: 4 pieces each
LK-31/-32: 6 pieces each
- *4 LK-11: M4×35
LK-21/-22: M5×30
LK-31/-32: M5×45
- *5 LK-11: M4
LK-21/-22/-31/-32: M5

■ LK-11/-21/-22/-31/-32 V6/VC/VS

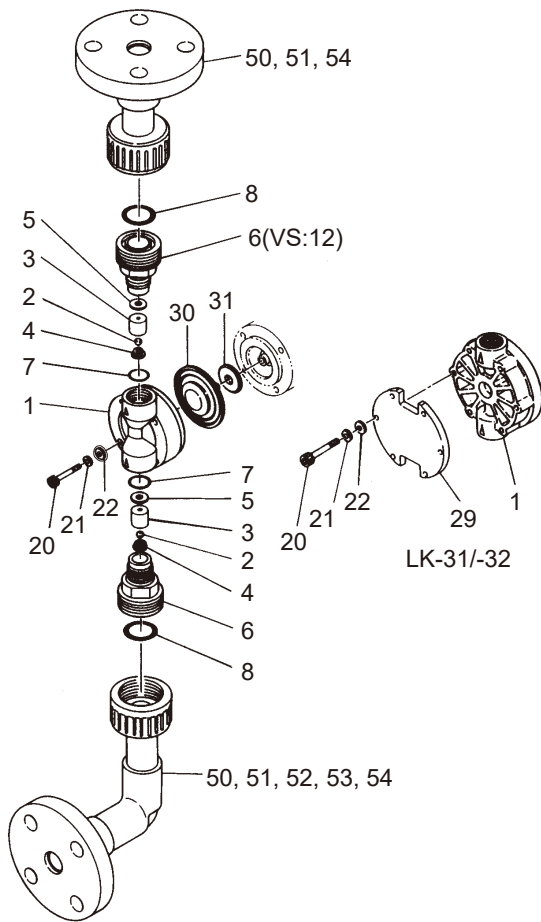

No.	Part names	# of parts	Materials			Remarks
			V6	VC	VS	
1	Pump head	1	PVC			
2	Valve	2	SUS316 equivalent	Ceramic	SUS316 equivalent	
3	Valve guide	2	PVC			
4	Valve seat	2	EPDM	FKM	SUS304	
5	Valve gasket	2	PTFE			
6	Adapter	2	PVC			One for VS
7	O ring	2	EPDM	FKM	EPDM	S14/P16*1
8	O ring	2	EPDM	FKM	EPDM	P20
12	Fitting	1	PVC			VS
20	Hex sock head bolt/ Hexagon bolts*2	4*3 (6)	Stainless steel			M4×35/ M5×30/ M5×45*4
21	Spring washer	4*3 (6)	Stainless steel			M4/M5*5
22	Plate washer	4*3 (6)	Stainless steel			M4/M5*5
29	Reinforcing plate	1	SS400			LK-31/-32
30	Diaphragm	1	PTFE/EPDM			
31	Retainer plate	1	SUS304			
50/51/52/53/54/	Inlet flange elbow unit	1	-			
(50)	Nut	1	PVC			
(51)	Union	1	PVC			
(52)	Elbow	1	PVC			
(53)	Pipe	1	PVC			
(54)	Flange	1	PVC			
50/51/54	Outlet flange unit	1	-			
(50)	Nut	1	PVC			
(51)	Union	1	PVC			
(54)	Flange	1	PVC			

- *1 LK-11/-21/-22: S14 O ring
LK-31/-32: P16 O ring
- *2 LK-11/-21/-22: Hex socket head bolt
LK-31/-32: Hexagon bolts
- *3 LK-11/-21/-22: 4 pieces each
LK-31/-32: 6 pieces each
- *4 LK-11: M4×35
LK-21/-22: M5×30
LK-31/-32: M5×45
- *5 LK-11: M4
LK-21/-22/-31/-32: M5

■ LK-45/-47/-55/-57 V6U/VCU/VSU

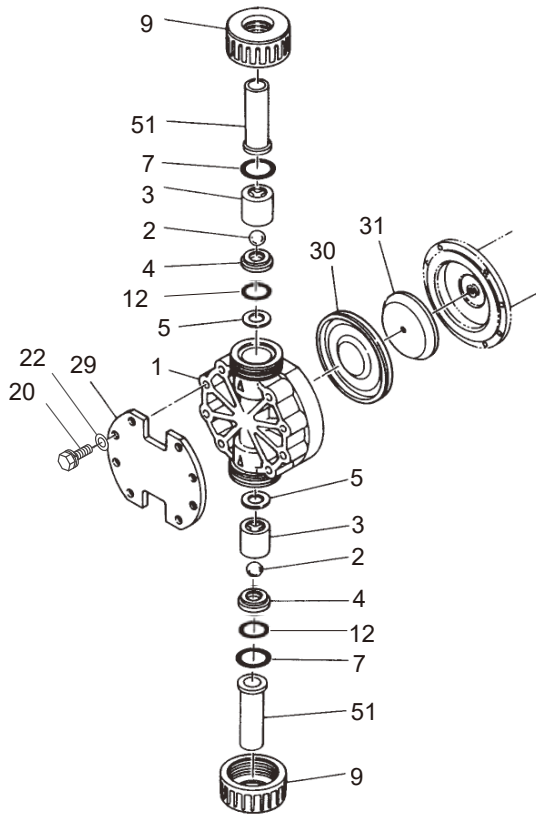

No.	Part names	# of parts	Materials			Remarks
			V6U	VCU	VSU	
1	Pump head	1	PVC			
2	Valve	2	SUS316 equivalent	Ceramic	SUS316 equivalent	
3	Valve guide	2	PVC			
4	Valve seat	2	PVC	PVC	SUS304	
5	Valve gasket	2	PTFE			
7	O ring	2	EPDM	FKM	EPDM	P32/ P38*1
9	Nut	2	PVC/GFRPP*2			
12	O ring	2	EPDM	FKM	EPDM	P26*3
20	Hexagon bolt	8	Stainless steel			M8×60/ M8×75 with SW*4
22	Plate washer	8	Stainless steel*3			
29	Reinforcing plate	1	SS400/FC200*5			
30	Diaphragm	1	PTFE/EPDM			
31	Retainer plate	1	SUS304			
51	Union	2	PVC			

*1 LK-45/-47: P32 O ring

LK-55/-57: P38 O ring

*2 LK-45/-47: PVC nut

LK-55/-57: GFRPP nut

*3 LK-55/-57 only

*4 LK-45/-47: M8×60

LK-55/-57: M8×75

*5 LK-45/-47: SS400

LK-55/-57: FC200

■ LK-45/-47 V6H/VCH & LK-45 VSH

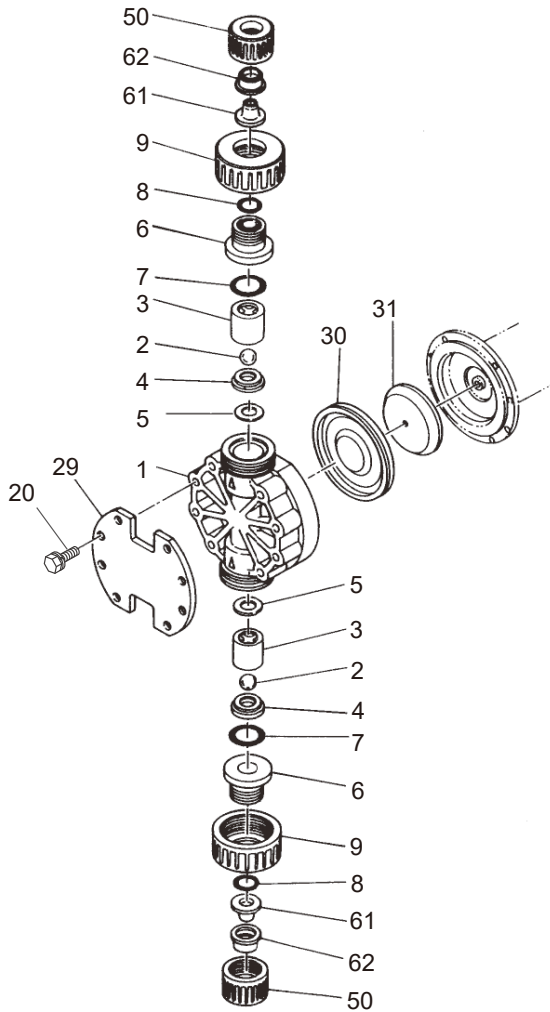

No.	Part names	# of parts	Materials			Remarks
			V6H	VCH	VSH	
1	Pump head	1	PVC			
2	Valve	2	SUS316 equivalent	Ceramic	SUS316 equivalent	
3	Valve guide	2	PVC			
4	Valve seat	2	PVC	PVC	SUS304	
5	Valve gasket	2	PTFE			
6	Adapter	2	PVC			
7	O ring	2	EPDM	FKM	EPDM	P32
8	O ring	2	EPDM	FKM	EPDM	P20
9	Nut	2	PVC			
20	Hexagon bolt	8	Stainless steel			M8×60 with SW
29	Reinforcing plate	1	SS400			
30	Diaphragm	1	PTFE/EPDM			
31	Retainer plate	1	SUS304			
50	Nut	2	PVC			
61	Tube insert	2	PVC			
62	Ferrule	2	SS400			

*LK-47 VSH is not available.

■ LK-45/-47/-55/-57 V6/VC/VS

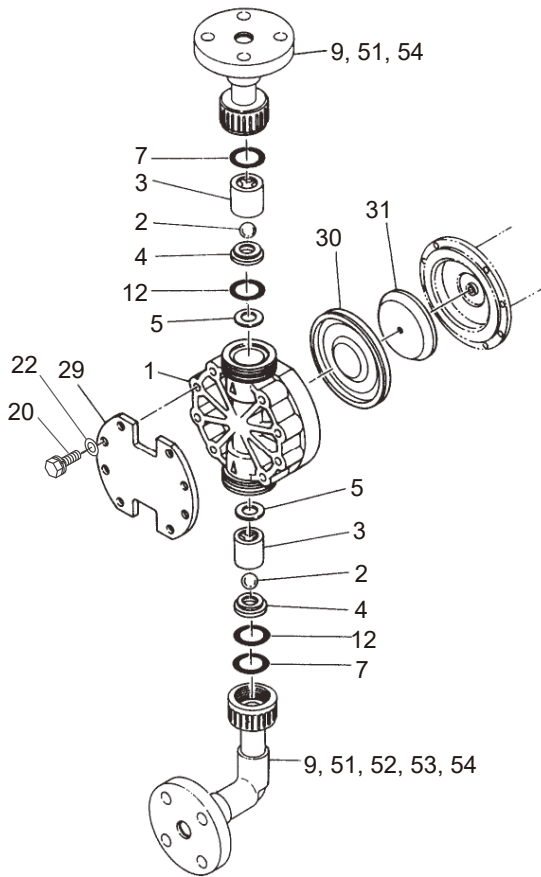

No.	Part names	# of parts	Materials			Remarks
			V6	VC	VS	
1	Pump head	1	PVC			
2	Valve	2	SUS316 equivalent	Ceramic	SUS316 equivalent	
3	Valve guide	2	PVC			
4	Valve seat	2	PVC	PVC	SUS304	
5	Valve gasket	2	PTFE			
7	O ring	2	EPDM	FKM	EPDM	P32/ P38*1
12	O ring	2	EPDM	FKM	EPDM	P26*2
20	Hexagon bolt	8	Stainless steel			M8×60/ M8×75 with SW*3
22	Plate washer	8	Stainless steel*2			
29	Reinforcing plate	1	SS400/FC200*4			
30	Diaphragm	1	PTFE/EPDM			
31	Retainer plate	1	SUS304			
9/ 51/ 52/ 53/ 54	Inlet flange elbow unit	1	-			
(9)	Nut	1	PVC/GFRPP*5			
(51)	Union	1	PVC			
(52)	Elbow	1	PVC			
(53)	Pipe	1	PVC			
(54)	Flange	1	PVC			
9/ 51/ 54	Outlet flange unit*6	1	-			
(9)	Nut	1	PVC/GFRPP*5			
(51)	Union	1	PVC			
(54)	Flange	1	PVC			

*1 LK-45/-47: P32 O ring

LK-55/-57: P38 O ring

*2 LK-55/-57 only

*3 LK-45/-47: M8×60

LK-55/-57: M8×75

*4 LK-45/-47: SS400

LK-55/-57: FC200

*5 LK-45/-47: PVC nut

LK-55/-57: GFRPP nut

*6 LK-47 VS: Outlet flange elbow unit

■ LK-11/-21/-22/-31/-32 S6

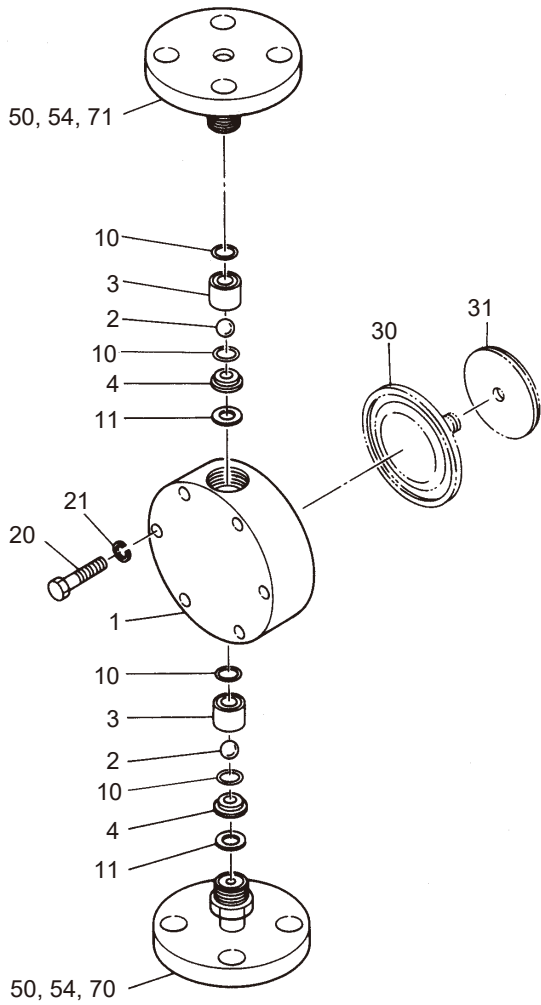

No.	Part names	# of parts	Materials	Remarks
1	Pump head	1	SUS316	
2	Valve	2	SUS316 equivalent	
3	Valve guide	2	SUS316	
4	Valve seat	2	SUS316	
10	Valve gasket A	4	PTFE	
11	Valve gasket B	2	PTFE	
20	Hexagon bolt	4 ^{*3} (6)	Stainless steel	M4×40/ M5×35/ M5×45 ^{*1}
21	Spring washer	4 ^{*3} (6)	Stainless steel	M4/M5 ^{*2}
30	Diaphragm	1	PTFE/EPDM	
31	Retainer plate	1	SUS304	
50/ 54/ 70 (71)	Inlet/outlet flange unit	2	-	
(50)	Nut	2	SUS304	
(54)	Flange	2	SUS316	
(70)	Suction port	1	SUS316	
(71)	Discharge port	1	SUS316	

*1 LK-11: M4×40

LK-21/-22: M5×35

LK-31/-32: M5×45

*2 LK-11: M4

LK-21/-22/-31/-32: M5

*3 LK-11/-21/-22: 4 pieces each

LK-31/-32: 6 pieces each

■ LK-45/-47/-55/-57 S6

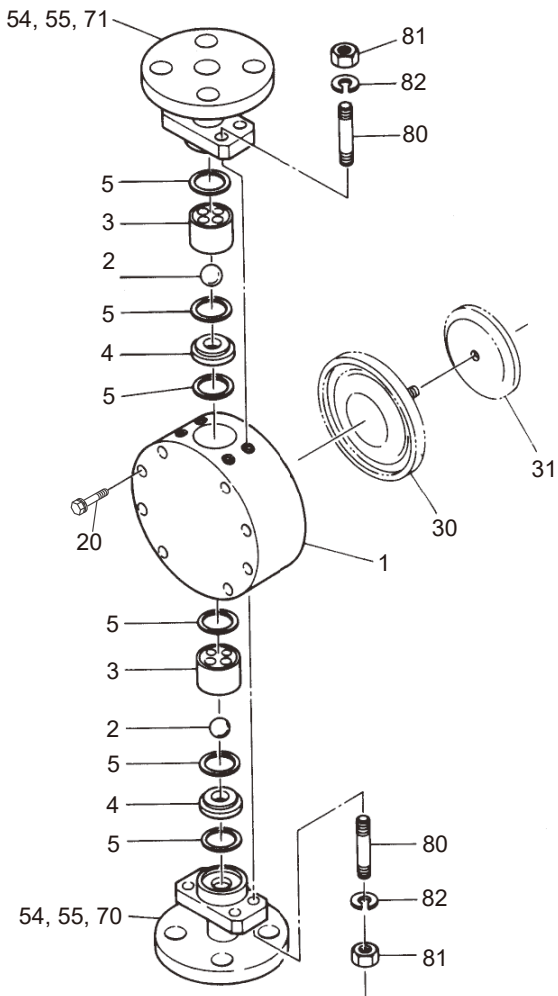

No.	Part names	# of parts	Materials	Remarks
1	Pump head	1	SUS316	
2	Valve	2	SUS316 equivalent	
3	Valve guide	2	SUS316	
4	Valve seat	2	SUS316	
5	Valve gasket	6	PTFE	
20	Hexagon bolt	8	Stainless steel	M8×65 with SW
30	Diaphragm	1	PTFE/EPDM	
31	Retainer plate	1	SUS304	
54/ 55/ 70 71	Inlet/outlet flange unit	2	-	
(54)	Flange	2	SUS316	
(55)	Setting flange	2	SS400	
(70)	Suction port	1	SUS316	
(71)	Discharge port	1	SUS316	
80	Stud bolt	8	Stainless steel	
81	Hexagon nut	8	Stainless steel	M8/M10*1
82	Spring washer	8	Stainless steel	M8/M10*1

*1 LK-45/-47: M8
LK-55/-57: M10

Specifications/Outer dimensions

Specifications

Information in this section is subject to change without notice.

Model code	Max flow L/min		Max pressure MPa	Viscosity mPa·S		Stroke rate spm		Stroke length mm	Connection		
	50Hz	60Hz		PVC	SUS	50Hz	60Hz		Tube	Union	Flange
LK-11	0.020	0.024	1.0 1.5(S6)	VC:300 V6:500	500	48	58	1.5	∅4×∅9	VP-16 /VP-25 (47VS)	JIS 10K 15A (V6/VC/VS) /JIS 10K 25A (47VS) /JIS 16K 15A (S6)
LK-21	0.050	0.060				96	116	2			
LK-22	0.10	0.12				48	58	2.5			
LK-31	0.25	0.30				96	116				
LK-32	0.50	0.60				48	58	6			
LK-45	0.85	1.00				96	116				
LK-47	1.70	2.00	0.8	1000	48	58	10	∅12×∅18	VP-25	JIS 10K 25A	
LK-55	2.80	3.30	0.5		96	116					
LK-57	6.00	7.20	0.3		96	116					

*The above information is based on pumping clean water at ambient temperature.

*The S6 type has the flange connection only.

*For the LK-31/-32/-45/-47 H (tube connection code), observe the maximum allowable pressure of a connected tube.

*Accuracy: ±2%FS

*Linearity: ±3%FS

*Allowable liquid temperature: 0-50°C (V6/VC/VS), 0-80°C (S6)

*Suction lift: 1m (with full stroke length)

*Ambient temperature: 0-40°C

Outer dimension

Unit: mm

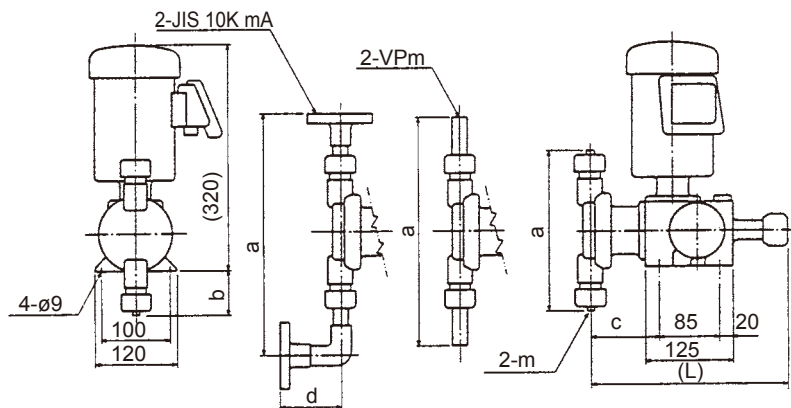

*The inlet/outlet flange ports of the S6 type are oriented vertically.

Model code	Tube connection					Union connection					Flange connection										
	PVC					PVC					PVC					SUS					
	L	a	b	c	m	L	a	b	c	m	L	a	b	c	d	m	L	a	b	c	m
LK-1	275	146	23	95	*	275	244	72	95	16	275	264	86	95	89	15	272	141	20	92	15
LK-2	275	164	32	95	*	275	262	81	95	16	274	282	95	95	89	15	272	151	25	92	15
LK-3	277	224	62	97	*	277	318	109	97	16	277	342	125	97	89	15	277	184	42	97	15
LK-4	281	249	72	99	*	281	337	119	99	16	281	361	135	99	89	15	283	261	80	101	15
LK-5	-	-	-	-	*	298	314	107	114	25	298	338	125	114	97	25	295	320	110	111	25
47VS	-	-	-	-	*	281	272	86	99	25	281	308	104	99	97	25	-	-	-	-	-

*Applicable tube ID: LK-1/-2 VC/V6: ∅4×∅9 LK-3/-4 VC/V6: ∅12×∅18 LK-1/2/-3/-4 VS: ∅12×∅18

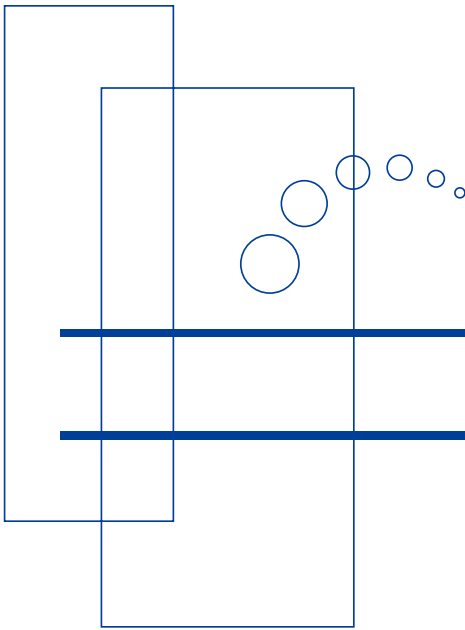

<https://www.iwakupumps.jp>

IWAKI CO.,LTD. 6-6 Kanda-Sudacho 2-chome Chiyoda-ku Tokyo 101-8558 Japan
TEL: +81 3 3254 2935 FAX: +81 3 3252 8892

European Headquarter / IWAKI Europe GmbH
TEL: +49 2154 9254 0 FAX: +49 2154 9254 48

Germany / IWAKI Europe GmbH
TEL: +49 2154 9254 50 FAX: +49 2154 9254 55

The Netherlands / IWAKI Europe GmbH (Netherlands Branch)
TEL: +31 74 2420011 FAX: +49 2154 9254 48

Italy / IWAKI Europe GmbH (Italy Branch)
TEL: +39 0445 561219 FAX: +39 0445 569088

Spain / IWAKI Europe GmbH (Spain Branch)
TEL/FAX: +34 934 741 638

Poland / IWAKI Europe GmbH (East Europe Branch)
TEL: +48 12 347 0755 FAX: +48 12 347 0900

Belgium / IWAKI Belgium N.V.
TEL: +32 13 670200 FAX: +32 13 672030

Denmark / IWAKI Nordic A/S
TEL: +45 48 242345

Finland / IWAKI Suomi Oy
TEL: +358 10 201 0490

France / IWAKI France S.A.
TEL: +33 1 69 63 33 70 FAX: +33 1 64 49 92 73

Norway / IWAKI Norge AS
TEL: +47 23 38 49 00

Sweden / IWAKI Sverige AB
TEL: +46 8 511 72900

U.S.A. / IWAKI America Inc.
TEL: +1 508 429 1440 FAX: +1 508 429 1386

Argentina / IWAKI America Inc. (Argentina Branch)
TEL: +54 911 6477 4116

Brazil / IWAKI Do Brasil Comercio De Bombas Hidraulicas LTDA.
TEL/FAX: +55 19 3244 5900

Singapore / IWAKI Singapore Pte Ltd.
TEL: +65 6316 2028 FAX: +65 6316 3221

Indonesia / IWAKI Singapore (Indonesia Office)
TEL: +62 21 6906606 FAX: +62 21 6906612

Malaysia / IWAKIm SDN. BHD.
TEL: +60 3 7803 8807 FAX: +60 3 7803 4800

Australia / IWAKI Pumps Australia Pty Ltd.
TEL: +61 2 9899 2411 FAX: +61 2 9899 2421

China (Hong Kong) / IWAKI Pumps Co., Ltd.
TEL: +852 2607 1168 FAX: +852 2607 1000

China (Guangzhou) / GFTZ IWAKI Engineering & Trading Co., Ltd.
TEL: +86 20 84350603 FAX: +86 20 84359181

China (Shanghai) / IWAKI Pumps (Shanghai) Co., Ltd.
TEL: +86 21 6272 7502 FAX: +86 21 6272 6929

Korea / IWAKI Korea Co., Ltd.
TEL: +82 2 2630 4800 FAX: +82 2 2630 4801

Taiwan / IWAKI Pumps Taiwan Co., Ltd.
TEL: +886 2 8227 6900 FAX: +886 2 8227 6818

Thailand / IWAKI (Thailand) Co., Ltd.
TEL: +66 2 322 2471 FAX: +66 2 322 2477