

**Chemically Resistant Self-Priming Magnetic Drive Pumps
Which Can Tolerate Abnormal Operation**

Main material
CFRETFE



Chemically Resistant Self-Priming Magnetic Drive Pumps which Can Tolerate Abnormal Operation



The SMX-F is a horizontal self-priming magnetic drive pump made from fluororesin. Our original self-radiation structure enhances resistance to dry running, cavitation, and closed-discharge operation. In addition, the use of standard motors extends the range of application.



SMX-F543

SMX-F441

SMX-F221



Excellent Corrosion Resistance

The casings, impeller assembly and magnet capsule are made of fluororesin(CFRETFE). Other wet-end parts are made of highly corrosion resistant materials such as carbon, ceramic and the like. The pumps can handle almost type of chemicals including strong acid/alkali.



Enhanced Durability Under Abnormal Operation

Our original self-radiation structure efficiently disperses bearing friction heat to protect the pump under abnormal operating conditions. In addition, our non-contact structure prevents contact between rear thrust face and bearing, to eliminate heat buildup during dry running.



Expanded Versatility

The SMX-F has a modular structure to handle liquids with high specific gravities. Use of standard motors extends the range of liquid application.



Easy Maintenance

The pump wet end can be removed from the motor as a complete assembly without dismantling, thanks to an additional rear casing support. The pump wet end comprises the minimum number of parts for easy maintenance.

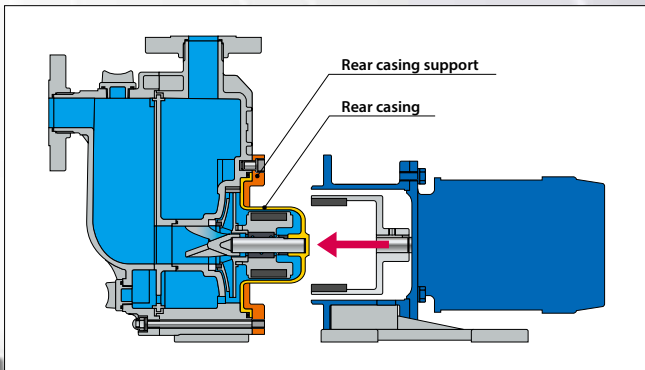
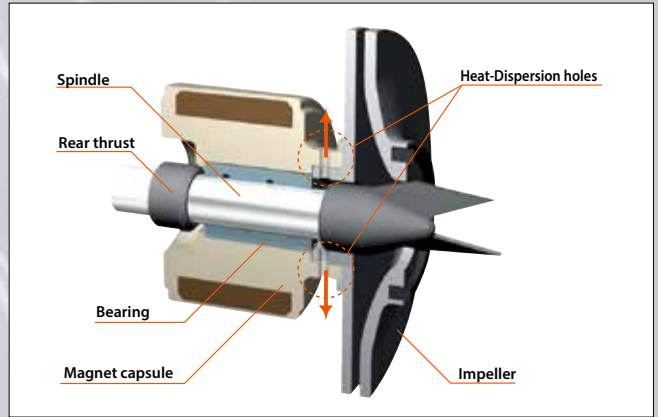

Fast Self-Priming

The SMX-F requires no external self-priming chambers or valves. The gas-liquid separation design ensures fast self-priming. An exceptional self-priming duration of up to 4m in only 90 seconds is now possible.

Rear casing support

The pump wet end is easily removed from the motor by removal of 4 mounting bolts on the motor bracket. The rear casing support performs easy maintenance and draining of any residual liquid at other place.

Examples of application

Pumping up from underground tank

- Underground tank at chemical plant.
- Underground tank or pit of waste plant.

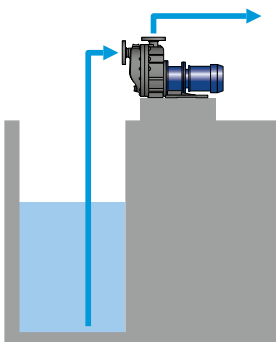

Pumping up and out from top of tank and tanker truck

- Transferring etching and plating chemical from chemical bath.
- Sucking up chemical from truck.
- Pumping up from top of tank.

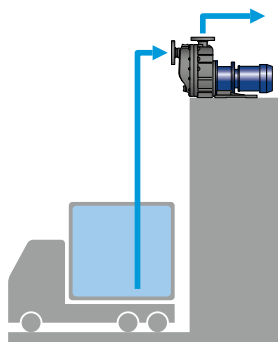

Transferring chemical from tank to tank

- Transferring from main tank to daily tank.
- Refilling chemical from drum to tank.

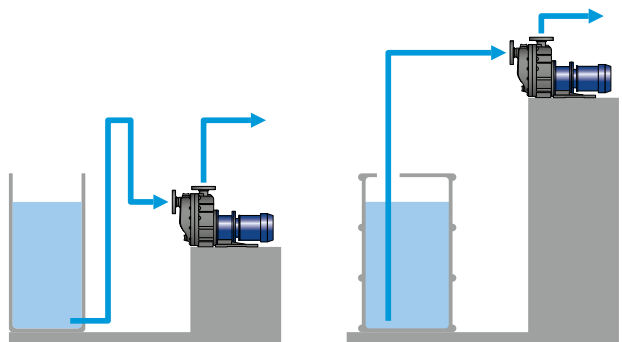

Reliability and Performance are Enhanced By our Unique Design

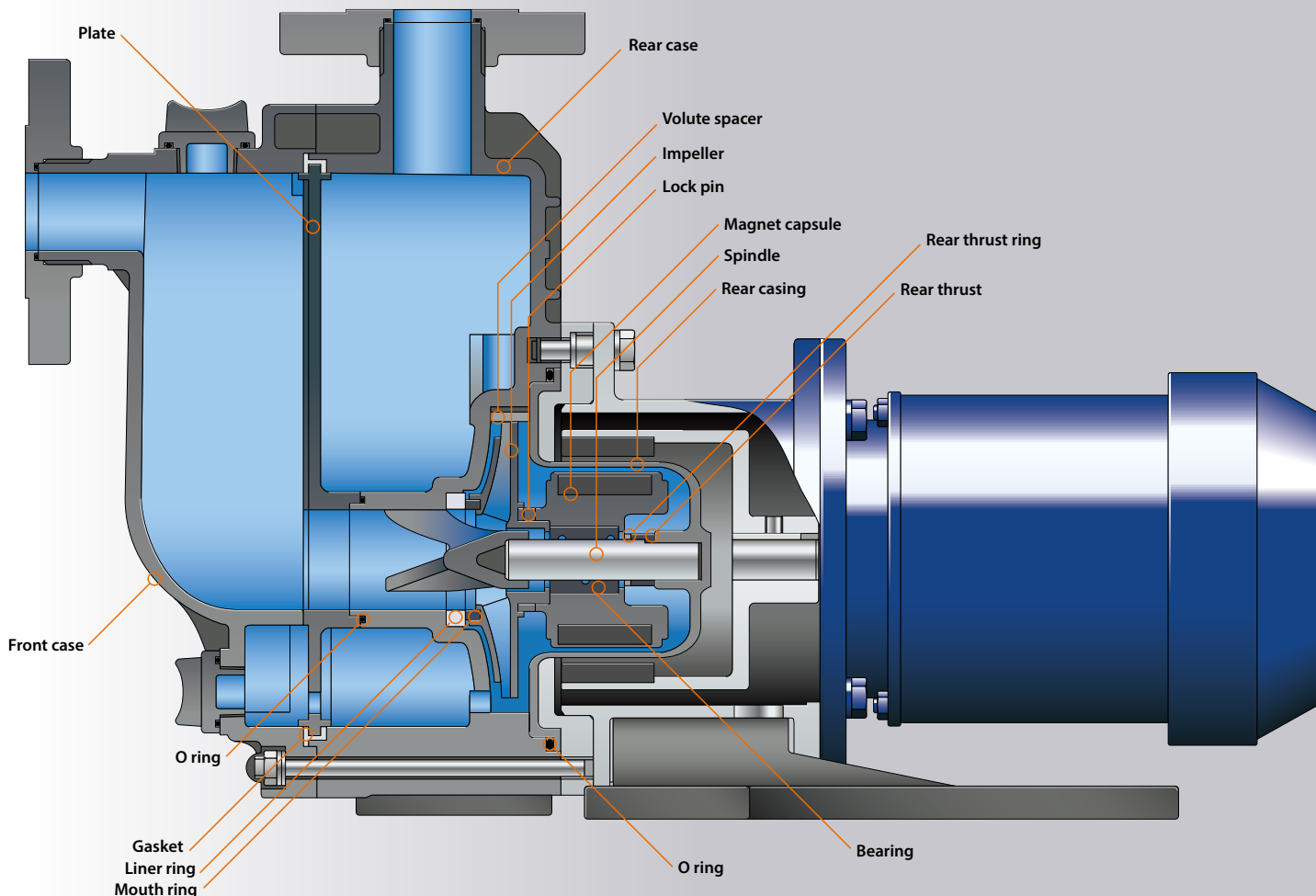

Wet-End Materials

Name of part	Model		
	CF	RF	KK
Front case			
Rear case			
Rear casing			
Volute spacer		CFRETFE	
Impeller			
Plate			
Magnet capsule			
O ring			
Gasket			
Spindle			
Liner ring			SiC
Rear thrust		CFRETFE	
Rear thrust		High purity alumina ceramic	SiC
Rear thrust ring		High purity alumina ceramic	-
Bearing	High density carbon	PTFE (With filler)	SiC
Mouth ring		PTFE (With filler)	
Lock pin		CFRETFE	

Note1 : 54 type only

Note2 : Exclusive for SMX-F22RF, 44RF



Principles of Self-Priming:

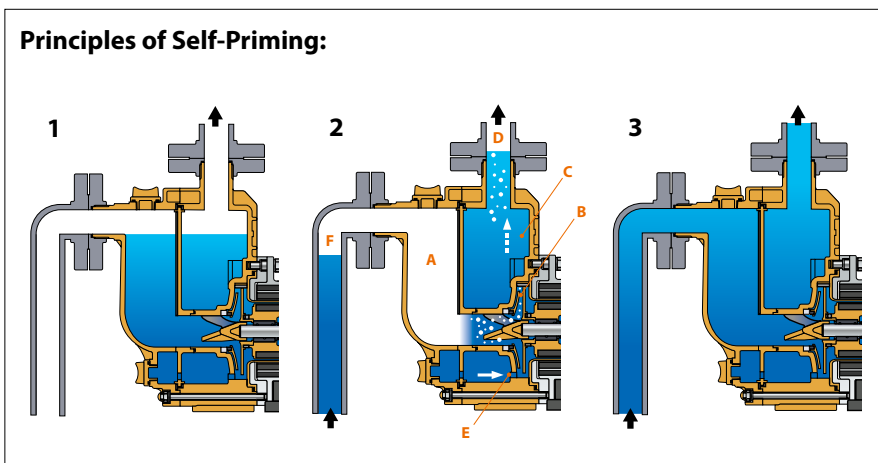

- 1** Prime the pump with liquid.
- 2** On starting, the pump will suck both gas and liquid into its inlet. This mixture moves through front case **A** to the front casing, where it is agitated by the impeller. The mixture is discharged through pump chamber **B** to rear case **C**, where gas and liquid separation then occurs. Gas is bled from the discharge port **D** while some liquid is retained. Liquid in the rear case **C** is fed back through circulation hole **E** to the front casing, where it is again mixed with entrained gas by the impeller. This recirculation & bleeding process continues until gas from the suction side **F** is completely expelled.
- 3** Once all gas is expelled, normal centrifugal pump operation is resumed. Sufficient liquid remains in the casing for subsequent self-priming once the pump is stopped.

Specifications

Model	Connection Suction×Discharge	Impeller	Cycle (Hz)	Min. capacity (L/min)	Standard specification (L/min-m)	Max. capacity (L/min)	Motor (kW 2P)	Resisting pressure limit (MPa)	Mass (kg)
SMX-F220	25A×25A	V	50	10	80 - 7.5	125	0.4	0.28	23
SMX-F221		Y	60		80 - 6.8	90			
		T	50		100 - 12.5	115	0.75		
SMX-F222		V			60	80 - 7.5			
		X	60		100 - 12.0	115	1.5		
Y		80 - 6.8			130				
SMX-F441	40A×40A	T	50	10	100 - 12.5	155	0.75	0.33	34
		Y	60		150 - 10.6	220			
SMX-F442		T	50		150 - 11.8	280	1.5		
		X	60		200 - 17.0	340			
SMX-F443		Y			60	150 - 10.6	280		
		X	200 - 17.0			340			
SMX-F542	50A×40A	V	50	20	100 - 19.8	155	1.5	0.40	52
SMX-F543		T			250 - 16.0	440			
		V	60		200 - 16.0	410	2.2		
Z		250 - 18.0			420				
SMX-F545		T	50		250 - 16.0	440	3.7		
		V			200 - 16.0	410			
	X	60	300 - 24.0	520					
	Y		300 - 21.0	500					
Z	250 - 18.0	420							

- The self-priming height limit noted above refers to a liquid equivalent to fresh water at 20°C. The self-priming height limit varies with the liquid temperature and the type of liquid.
- Temperature range of handled liquid: 0 to 80°C (The self-priming height limit decreases at high temperatures.)
- Mass weight includes a outdoor motor.

Pump Identification

SMX-F - 22 0 CA V V C

1 2 3 4 5 6 7

1 Series symbol
SMX-F : CFRETPE type

2 Pump size (Suction×Discharge)
22 : 25A×25A
44 : 40A×40A
54 : 50A×40A

3 Motor output
0 : 0.4kW
1 : 0.75kW
2 : 1.5kW
3 : 2.2kW
5 : 3.7kW

4 Materials of Bearing / Spindle / Lining ring)
CF : High density carbon / High purity alumina ceramic / High purity alumina ceramic
RF : PTFE (with filler) / High purity alumina ceramic / High purity alumina ceramic
KK : SiC/SiC/ SiC

5 Materials of O-ring
V : FKM
E : EPDM

6 Impeller
T, V : 50Hz
X, Y, Z : 60Hz

7 Motor specifications
No symbol : TFEC indoor
C : TFEC outdoor
A : Increased safety type, outdoor
(Except SMX-F443)

Note: All combination of impeller and motor size are not available. Please contact Iwaki for detail.

Dimensions (mm)

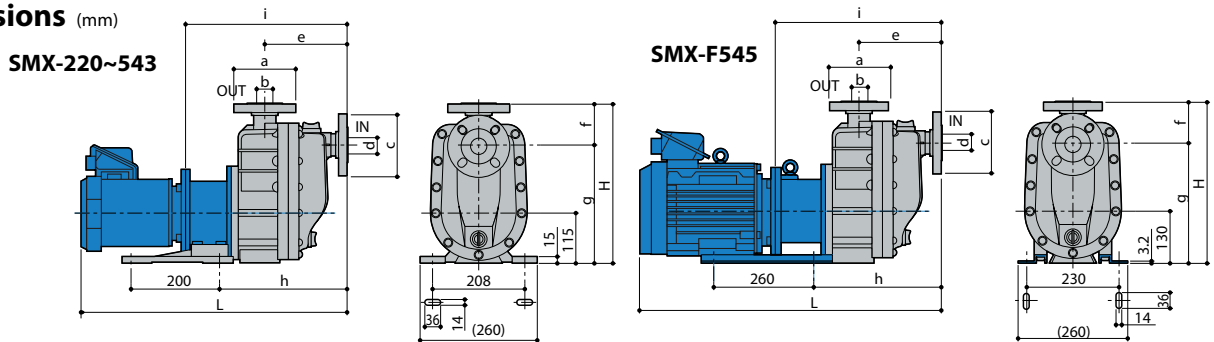

Model	(H)	(L)	a	(b)	c	(d)	(e)	(f)	g	(h)	(i)	j
SMX-F220	329	539	Ø125	Ø25	Ø125	Ø25	162	74	255	240	308	115
SMX-F221		556									320	
SMX-F222		605									332	
SMX-F441	364	602	Ø140	Ø40	Ø140	Ø40	188	93	271	285	366	115
SMX-F442		651									378	
SMX-F443		680										
SMX-F542	390	661	Ø140	Ø40	Ø155	Ø50	204	100	289	310	388	130
SMX-F543		690									408	
SMX-F545		734										

Note: The dimensions may differ with the type of motor installed.

Performance Curves

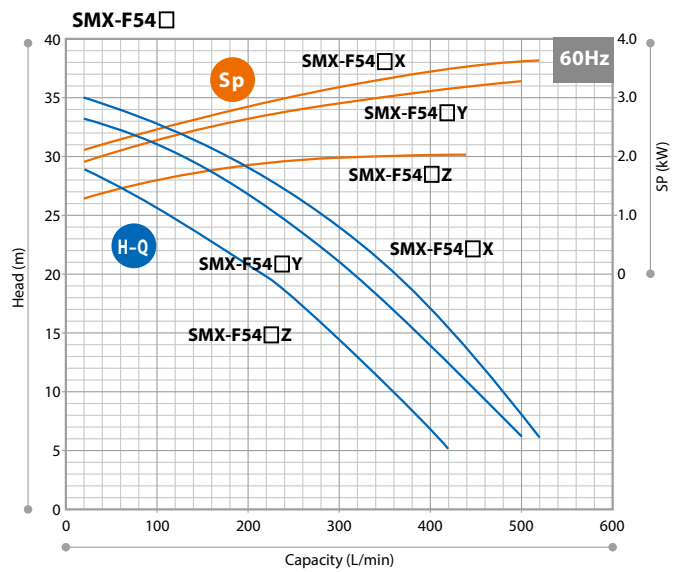
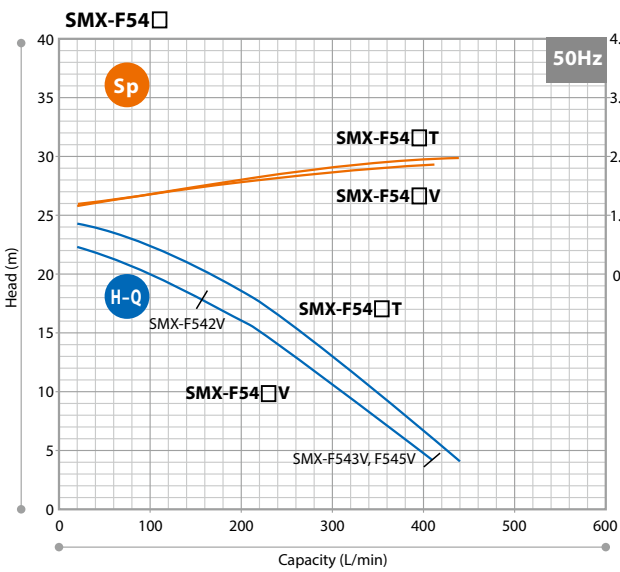
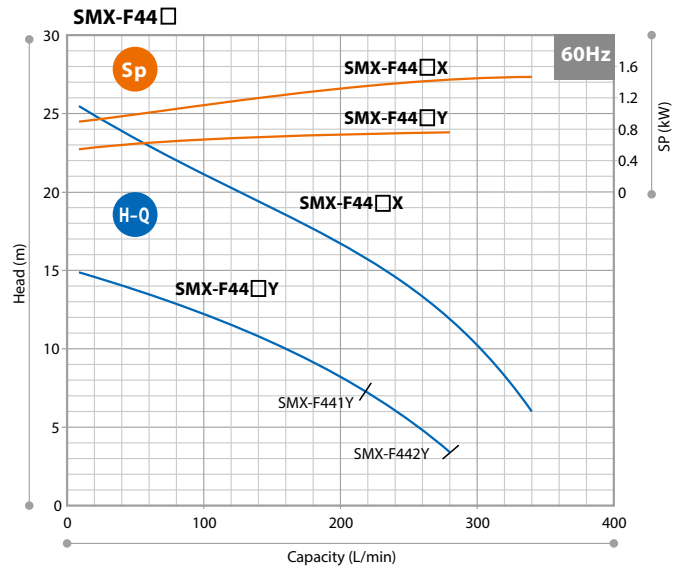
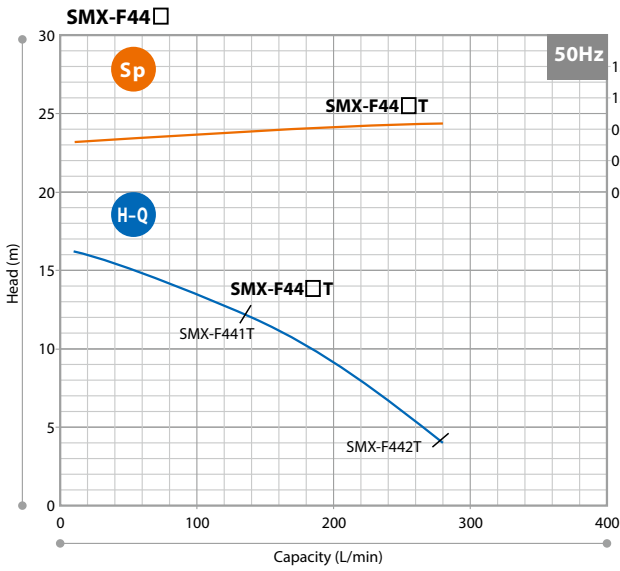
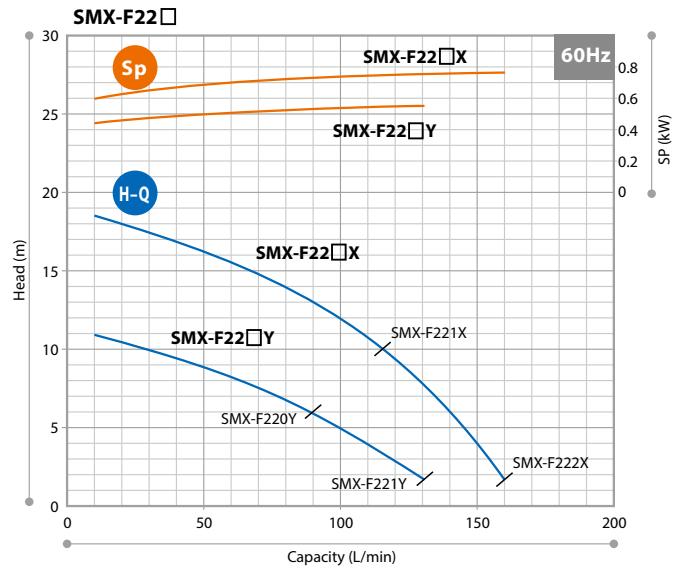
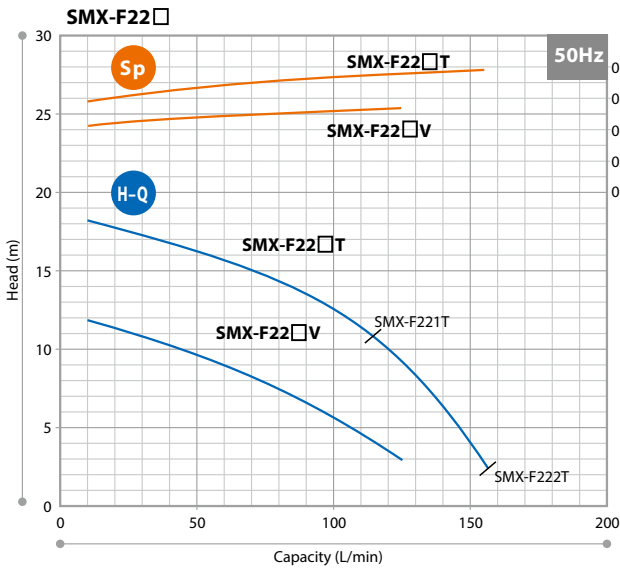

• The shaft power curves shown above are calculated by using our standard test motor. Contact us for detail.

Precautions on the selection of pumps

- The performance curves on this catalogue are based on the operation with 20°C clean water in flooded suction. Keep a margin (3% of the curves) when selecting the pump.
The minimum flow rate SMX-F22□: 10L/min
SMX-F44□: 10L/min
SMX-F54□: 20L/min
- The magnetic pump cannot run continuously with a closed-discharge. Be sure to observe the minimum flow rate.
3. Select a pump model according to liquid specific gravity. Always keep 10% allowance to motor output.
Pump shaft power Sp x Specific gravity x 1.1 (margin) ≤ Motor output
- The self-priming performance (4m in 90 seconds) is based on the operation with 20°C clean water on the right piping condition. Self-priming performance varies with liquid temperature, characteristics and piping conditions. Obtain a rough guide of the highest possible self-priming height at each liquid specific gravity by the following formula.
The highest possible self-priming height[m] = Self-priming height with clean[m] / Liquid specific gravity

Self-priming considerations

- The diameter of the piping on the suction side should be the same as that of the pumps inlet port,
SMX-F22□: 25mm
SMX-F44□: 40mm
SMX-F54□: 50mm
and the length of the piping should be limited to less than 4.7m. A larger pipe diameter or longer piping could adversely affect the self-priming performance, or could even hinder the self-priming process itself.
- In cases where the liquid level fluctuates, take the height from the lowest liquid level as the maximum self-priming height.
- Always perform priming before first operation, and start the pump only after the pump chamber has been filled with the handled liquid.
- To prevent early deterioration, avoid frequent start/stop of the pump.
- If a foot valve is installed on the suction pipe, pipe resistance may increase so that the pump cannot suck liquid enough.
- When installing a check valve, install an air vent line to release the air.
- Pipe support
If piping weight loads the pump, plastic parts are deformed. Be sure to install a pipe support.

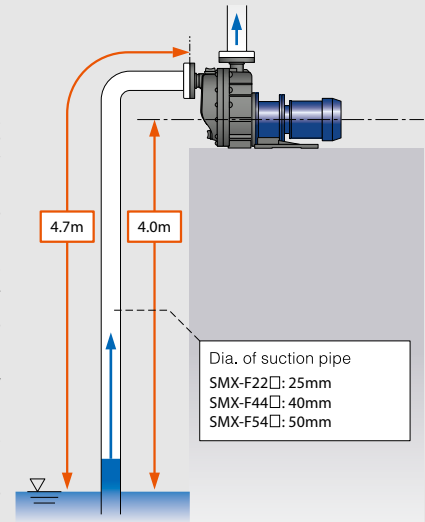

Optional Accessories

Pump Protector DRN Series

Detects Unusual Pump Operating Conditions Including Dry-Running and Overload

The DRN model protects equipment (including pumps) from damage!
Minimizes production downtime.
Identifies possible causes of alarms so they can be investigated and addressed.



- Multiple Input** Two analog, one digital, one temperature input and one current input.
- Easy Operation** Equipped with EASY setup mode to remember the operation status and set the lower/upper limit values, as well as AUTO setup mode.
- Bar Graph** Visible indication of current operating status. (Refer to the figure below)
- Logging Capability** Data log feature for preventative maintenance scheduling.
- Communication** RS485 external communication capability.
- Clamp-Type Current Sensor for Ease of Installation** No modification of motor leads necessary.

Specifications

Model	DRN-01	DRN-02
Amperometric range	0.5-30.00A	5.0-200.0A
Unit's source voltage	AC100-240V 50/60Hz 10VA	
Operating temperature	0-40°C	
Operating humidity	35-85%RH	

IWAKI CO., LTD. 6-6 Kanda-Sudacho 2-chome Chiyoda-ku Tokyo 101-8558 Japan TEL : (81)3 3254 2935 FAX : 3 3252 8892 IWAKI has global net work. Please find your distributor location at www.iwakupumps.jp

European Headquarter Germany	IWAKI Europe GmbH TEL: (49)2154 9254 0	FAX: (49)2154 9254 48	U.S.A.	IWAKI America Inc. TEL: (1)508 429 1440	FAX: (1)508 429 1386
The Netherlands (Netherlands Branch)	IWAKI Europe GmbH TEL: (49)2154 9254 50	FAX: (49)2154 9254 55	Brazil	IWAKI Do Brasil Comercio De Bombas Hidraulicas LTDA. TEL: (55)19 3244 5900	FAX: (55)19 3244 5900
Italy (Italy Branch)	IWAKI Europe GmbH TEL: (31)74 2420011	FAX: (49)2154 9254 48	China (Shanghai)	IWAKI Pumps (Shanghai) Co., Ltd. TEL: (86)21 6272 7502	FAX: (86)21 6272 6929
Spain (Spain Branch)	IWAKI Europe GmbH TEL: (39)0445 561219	FAX: (39)0445 569088	China (Hong Kong)	IWAKI Pumps Co., Ltd. TEL: (852)2607 1168	FAX: (852)2607 1000
Poland (East Europe Branch)	IWAKI Europe GmbH TEL: (34)934 741 638	FAX: (34)934 741 638	China (Guangzhou)	GFTZ IWAKI Engineering & Trading Co., Ltd. TEL: (86)20 84350603	FAX: (86)20 84359181
Denmark	IWAKI Europe GmbH TEL: (48)12 347 0755	FAX: (48)12 347 0900	Singapore	IWAKI Singapore Pte Ltd. TEL: (65)6316 2028	FAX: (65)6316 3221
Finland	IWAKI Nordic A/S TEL: (45)48 242345		Indonesia (Indonesia Office)	IWAKI Singapore Pte Ltd. TEL: (62)21 6906606	FAX: (62) 21 6906612
Norway	IWAKI Suomi Oy TEL: (358)10 201 0490		Malaysia	IWAKim SDN. BHD. TEL: (60)3 7803 8807	FAX: (60)3 7803 4800
Sweden	IWAKI Norge AS TEL: (47)23 38 49 00		Korea	IWAKI Korea Co.,Ltd. TEL: (82)2 6238 4800	FAX: (82)2 6238 4801
Belgium	IWAKI Sverige AB TEL: (46)8 511 72900		Taiwan	IWAKI Pumps Taiwan Co., Ltd. TEL: (886)2 8227 6900	FAX: (886)2 8227 6818
France	IWAKI Belgium N.V. TEL: (32)13 670200	FAX: (32)13 672030	Thailand	IWAKI (Thailand) Co.,Ltd. TEL: (66)2 322 2471	FAX: (66)2 322 2477
	IWAKI France S.A. TEL: (33)1 69 63 33 70	FAX: (33)1 64 49 92 73	Australia	IWAKI Pumps Australia Pty Ltd. TEL: (61)2 9899 2411	FAX: (61)2 9899 2421

Caution for safety use: Before use of pump, read instruction manual carefully to use the product correctly. Actual pumps may differ from the photos. Specifications and dimensions are subject to change without prior notice. For further details please contact us.

Legal attention related to export. Our products and/or parts of products fall in the category of goods contained in control list of international regime for export control. Please be reminded that export license could be required when products are exported due to export control regulations of countries. The posting and copying from this catalogue without permission is not accepted firmly.