

# Iwaki Direct Drive Pump

---

## RD-40 (built-in type)

---

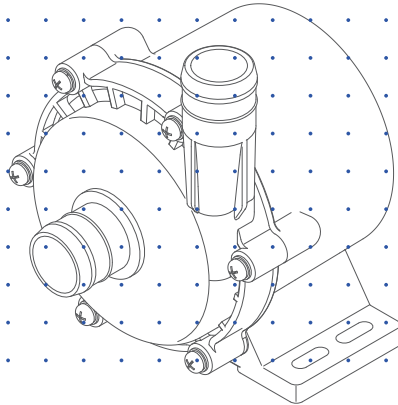

## Instruction manual

Thank you for choosing our product.



Please read through this instruction manual before use.



This instruction manual describes important precautions and instructions for the product. Always keep it on hand for quick reference.

## Order confirmation

Open the package and check that the product conforms to your order. If any problem or inconsistency is found, immediately contact your distributor.

### a. Check if the delivery is correct.

Check the nameplate to see if the information such as model codes, discharge capacity and discharge pressure are as ordered.

Iwaki Direct Drive Pump			
MODEL			
MAX.CAPACITY	ℓ/min	VOLTS	V
MAX.HEAD	m	AMPS	A
RATING	Year		
<b>DO NOT RUN PUMP DRY</b> 			
MFG.No.			
<b>IWAKI CO.,LTD.</b> 6-6,Kanda-Sudacho 2-chome Chiyoda-ku Tokyo Japan 			

Spec label for the European market

Iwaki Direct Drive Pump			
MODEL			
MAX.CAPACITY	ℓ/min	VOLTS	V
MAX.HEAD	m	AMPS	A
RATING			
<b>DO NOT RUN PUMP DRY</b>			
MFG.No.			
<b>IWAKI CO.,LTD.</b> MADE IN JAPAN 			

Spec label for any area other than the European market

\*The CE marking on our product(s) is for us to market the product(s) into the European market, however, the CE marking does not ensure any safety or conformity of the product(s) outside the European market.

When the pump is incorporated into the equipment marketed in the European market, such equipment must meet all the requirements of applicable directives. In such a case, any person who places the equipment on the market must carry a CE mark on the equipment as a manufacturer.

### b. Check if the delivery is damaged or deformed.

Check for transit damage and loose bolts.

# Contents

Order confirmation ..... 2

## **Safety instructions ..... 5**

WARNING..... 6

CAUTION..... 7

Precautions for use ..... 9

## **Overview..... 11**

Introduction ..... 11

    Pump structure & Operating principle ..... 11

Part names..... 12

Introduction..... 12

    Before operation ..... 12

    Priming..... 13

    Liquid to be handled ..... 13

    ON-OFF operation..... 13

Identification codes..... 14

## **Installation ..... 15**

Pump mounting..... 15

Pipework ..... 16

    Plumbing layout ..... 16

        Discharge & Suction valves ..... 17

        Pressure gauge ..... 17

        Drain valve..... 17

    Plumbing..... 17

    Plumbing precautions ..... 19

        Suction line..... 19

        Discharge line..... 20

<b>Wiring</b> .....	<b>21</b>
Power & External signal cables.....	21
Before wiring .....	21
Rated current & Starting current .....	22
Wiring examples .....	23
Specification (connector).....	23
Wiring diagram (option cable) .....	23
Wiring diagram (with no 1-5VDC signal generator) .....	24

## **Operation.....25**

<b>Pump operation</b> .....	<b>25</b>
Start-up.....	25
Shutdown.....	26

## **Maintenance.....27**

<b>Troubleshooting</b> .....	<b>27</b>
Retightening of pump head fixing screws.....	28
<b>Drainage</b> .....	<b>29</b>
Blowdown .....	29
<b>Inspection</b> .....	<b>31</b>
Daily inspection .....	31
<b>Specification/Outer dimension</b> .....	<b>32</b>
Specification .....	32
Outer dimension .....	33
RD-40/-40X.....	33
Performance curves .....	34
RD-40.....	34
RD-40X .....	34
Part names & Structure .....	35
EC DECLARATION OF CONFORMITY.....	36

# Safety instructions

**Read through this section before use. This section describes important information for you to prevent personal injury or property damage.**

## ■ Symbols

In this instruction manual, the degree of risk caused by incorrect use is noted with the following symbols. Please pay attention to the information associated with the symbols.



### **WARNING**

Indicates mishandling could lead to a fatal or serious accident.



### **CAUTION**

Indicates mishandling could lead to personal injury or property damage.

A symbol accompanies each precaution, suggesting the use of "Caution", "Prohibited actions" or specific "Requirements".

Caution marks		Prohibited mark			Requirement mark	
Caution	Electrical shock	Prohibited	Do not rework or alter	Keep fire away	Requirement	Wear protection



## **Export Restrictions**

Technical information contained in this instruction manual might be treated as controlled technology in your countries, due to agreements in international regime for export control.

Please be reminded that export license/permission could be required when this manual is provided, due to export control regulations of your country.

## WARNING

### **Turn off power before service**

Risk of electrical shock. Be sure to turn off power to stop the pump and related devices before service is performed.



Requirement

### **Stop operation**

If you notice any abnormal or dangerous conditions, suspend operation immediately and inspect/solve problems.



Requirement

### **Do not use the pump in any condition other than its intended purpose**

The use of the pump in any conditions other than those clearly specified may result in failure or injury. Use this product in specified conditions only.



Prohibited

### **Do not modify the pump**

Alterations to the pump carries a high degree of risk. It is not the manufacturer's responsibility for any failure or injury resulting from alterations to the pump.



Do not rework  
or alter

### **Wear protective clothing**

Always wear protective clothing such as an eye protection, chemical resistant gloves, a mask and a face shield during disassembly, assembly or maintenance work. The specific solution will dictate the degree of protection. Refer to MSDS precautions from the solution supplier.



Wear  
protectors

### **Use of hazardous chemicals**

Risk of personal injury or fire. Check/monitor plumbing system for a leak before or in operation when handling a flammable, corrosive or harmful liquid.



Caution

### **Do not damage the power cable**

Do not pull, knot, or crush the power cable. Damage to the power cable could lead to a fire or electrical shock if cut or broken.



Prohibited

### **Do not operate the pump in a flammable atmosphere**

Do not place explosive or flammable material near the pump.



Keep fire away

# CAUTION

## Qualified personnel only

The pump should be handled or operated by qualified personnel with a full understanding of the pump. Any person not familiar with the product should not take part in the operation or maintenance of the pump.



## Use specified power only

Do not apply power other than that specified on the nameplate. Otherwise, failure or fire may result. Ensure the pump is properly grounded.



## Do not run pump dry

Running the pump without liquid, friction heat builds up and damages the internal parts of pump.



## Ventilation

Fumes or vapors can be hazardous with certain solutions. Ensure proper ventilation at the operation site.



## Do not install/store the pump:

- Where ambient temperature can exceed 0-40°C.
- In a flammable atmosphere or in a dusty/humid environment.
- In direct sunlight or wind & rain.
- In mechanical vibration.
- In a corrosive atmosphere such as chlorine gas.



## Spill precautions

Ensure protection and containment of solution in the event of plumbing or pump damage (secondary containment).



## Do not stand on the pump

Personal injury may result as the pump turns over.



## Do not touch the pump or pipe with bare hands

Risk of burning. The surface temperature of the pump or pipe rises high along with liquid temperature in or right after operation.



---

**Keep electric parts and wiring dry**

Risk of fire or electric shock. Install the pump where it can be kept dry.



Prohibited

---

**Keep away from around the pump when turning ON power**

The pump doesn't have an ON-OFF switch and starts as the power cable is plugged in with 1-5VDC control voltage provided.



Requirement

---

**Remove foreign matters**

Turn off power and clean the pump if foreign matters enter the pump. Otherwise, the pump may be damaged.



Requirement

---

**Static electricity**

When low electric conductivity liquids such as ultra-pure water and fluor inactive liquid (e.g. Fluorinert™) are handled, static electricity may generate in the pump and may cause static discharge. Take countermeasures to remove static electricity.



Requirement

---

**Check pump head bolts**

Liquid may leak if any of pump head bolts become loose. Tighten the bolts diagonally and evenly by 1.6N•m before initial operation and at regular intervals.



Caution

---

**Do not use the pump in a wet location**

The pump is not waterproof. Use of the pump in wet or extremely humid locations could lead to electric shock or short circuit.



Prohibited

---

**Do no use a damaged pump**

Using a damaged pump could lead to an electric shock or death.



Prohibited

---

**Disposal of the used pump**

Dispose of any used or damaged pump in accordance with local rules and regulations. If necessary, consult a licensed industrial waste disposal company.



Requirement

---

**Do not pressurize the pump**

If the pump is pressurized over the maximum discharge pressure, O ring seal may be impaired and leakage may result.



Prohibited

## Precautions for use

- Electrical work should be performed by a qualified electrician. Otherwise, personal injury or property damage could result.



- Do not install the pump:
  - In a flammable/corrosive/explosive atmosphere.
  - In a dusty place.
  - In direct sunlight or wind & rain.
  - In mechanical vibration.
  - Where ambient temperature can exceed 0-40°C.
  - Where ambient humidity can exceed 35-85RH.

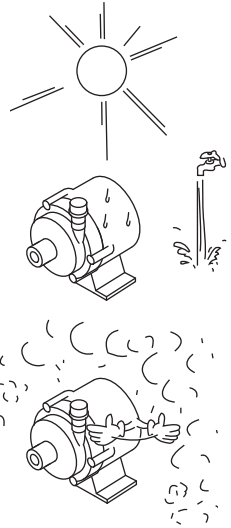

- Allow sufficient space around the pump for easy access and maintenance.



- Use care handling the pump. Do not drop. An impact may affect pump performance. Do not use a pump that has been damaged to avoid the risk of electrical damage or shock.



- This pump is not capable of self-priming. Always prime the pump before operation.

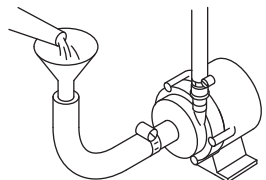

- The pump is not waterproof. Do not operate the pump while wet with solution or water. Failure or injury may result. Immediately dry off the pump if it gets wet.



- Do not close discharge line during operation. Solution may leak or piping may break.



- Solution in the discharge line may be under pressure. Release the pressure from the discharge line before disconnecting plumbing or disassembly of the pump to avoid solution spray.



- Wear protective clothing when handling or working with pumps. Consult solution MSDS for appropriate precautions. Do not come into contact with residual solution.



- Do not clean the pump or nameplate with a solvent such as benzine or thinner. This may discolour the pump or erase printing. Use a dry or damp cloth or a neutral detergent.



# Overview

***Pump characteristics, features and part names are described in this section.***

## Introduction

### ***Pump structure & Operating principle***

*The RD pump is a canned motor pump with a brushless DC motor.*

*The magnetic force of the motor rotates the driven magnet in order for the impeller to revolve in the pump chamber, where a liquid is transferred from the inlet to outlet.*

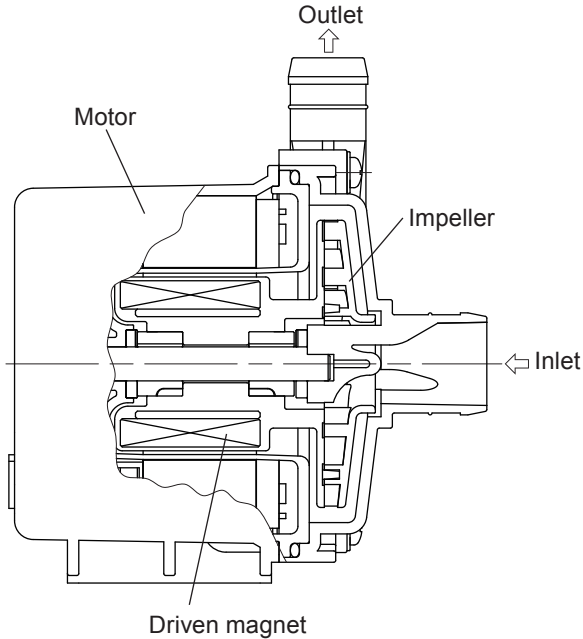

## Part names

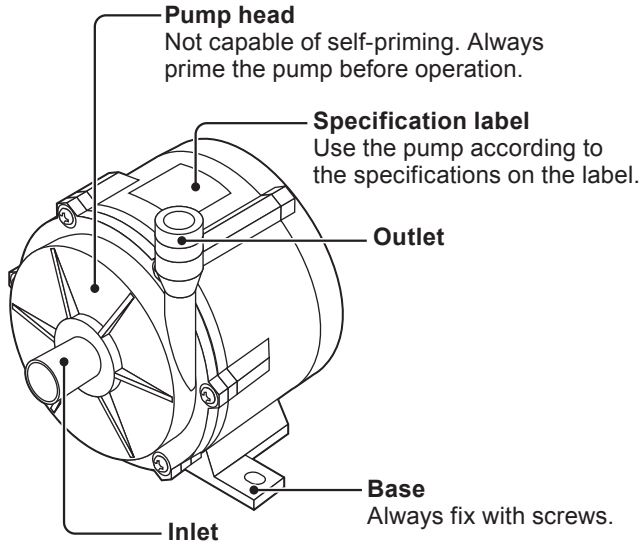

## Introduction

### ***Before operation***

*Water hammer phenomenon may occur when starting or stopping operation, especially when a discharge line is too long.*

#### **When starting operation:**

First prime the pump and close a discharge valve. Run the pump and then start to open the valve to meet a duty point slowly.

#### **When stopping operation:**

Slowly close a discharge valve until it bottoms out. Then turn off power to stop the pump.

\*Do not close a discharge line sharply, or water hammer phenomenon may occur and damage the pump with impact pressure.

## **Priming**

---

*This pump is not capable of self-priming. Always prime the pump before operation. Running the pump without priming water, internal parts are excessively worn by friction heat and fatal pump damage results.*

## **Liquid to be handled**

---

### **Do not use the following liquids.**

- Paraffinic hydrocarbons such as gasoline and kerosene
- Halogenated hydrocarbons such as trichloroethylene and carbon tetrachloride
- Ether and low-grade ester
- Slurry (never use slurry, which wears out the pump bearings.)
- Magnetic fluid
- Explosive or flammable liquid

### **A strong magnet is inside the pump.**

Do not use the pump with any liquid which contains metals such as iron and nickel.

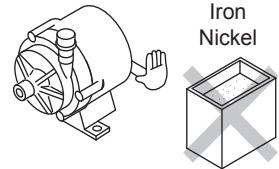

### **Observe the viscosity limit of 1mPa•s (at SG=1.0)**

Pure water may bring poor lubrication to the bearing. Contact us in advance.

### **Effect of temperature change**

Viscosity, vapour pressure or corrosiveness changes with liquid temperature.

Observe optimum operating conditions below.

- Liquid temperature: 0-80°C (clean water)
- Ambient temperature: 0-40°C
- Ambient humidity: 35-90&RH

## **ON-OFF operation**

---

*Do not turn on or off the pump 2 times or more per minute and observe the allowable shortest ON or OFF time of 15sec.*

## Identification codes

The model code represents the following information.

**RD - 40 - E 24 - H - V**  
**a    b   c   d   e    f   g   H**

**a. Series name**

RD

**b. Pump size**

40

40X

**c. Bearing material**

No code: Filled PTFE

**d. Oring material**

E: EPDM

**e. Power voltage**

2: 24VDC

**f. Liquid temperature**

H: High liquid temperature (0-80°C)

**g. Connection**

No code: Tube

R1: R pipe thread

N1: NPT pipe thread

**H. External input**

V: 1-5VDC

# Installation

**Installation of the pump, tubing and wiring are described in this section.**

## **!** Observe the following points

- Risk of electrical shock. Be sure to turn off power to stop the pump and related devices before service is performed.
- If you notice any abnormal or dangerous conditions, suspend operation immediately and inspect/solve problems.
- Do not place explosive or flammable material near the pump.
- Use of a damaged pump could lead to an electric shock or death.
- A strong magnet is inside the pump. Do not bring a watch or magnetic device which may be adversely affected by a magnetic force.

## Pump mounting

### **1** Select a suitable place.

Allow sufficient space around the pump for easy access and maintenance.

- Select a level location, free from vibration, that won't hold liquid. If the pump is not installed level, output may be affected.
- Keep good ventilation, taking account of the self-heating of pump.

### **2** Mounting position

This pump is not capable of self-priming and should be installed lower than the supply tank liquid level. Always keep a liquid level 30cm higher than the outlet of the tank, or air may enter a suction line and bearings may be worn badly.

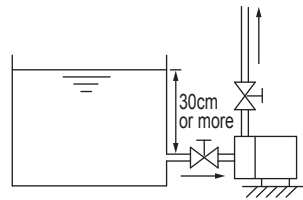

### **3** Anchor the pump.

Anchor the pump with four bolts so it doesn't vibrate.

See page 33 for suitable bolt size.

**NOTE**

Do not mount the pump in a vertical direction.

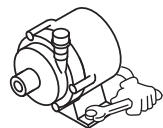

# Pipework

Connect tubes to the pump and install a check valve.

## Precautions

- Using a high flow pump and a small supply tank, a liquid level in the tank changes greatly.
- Do not allow a drop of adhesive agent or sealant into pipework. They may cause fatal damage to the pump.
- If pipework directory weighs on the pump, deformation or damage may result. Be sure to install pipe supports.
- Air may be entrained into a suction line when a supply tank is refilled during operation. Take any action to prevent air ingress such as installing a baffle.
- Make sure every joint in plumbing is securely sealed.
- Use a corrosion-/pressure-resistant vinyl tube such as a braided and a teflon tube, otherwise a suction tube can be crushed by negative pressure (especially for hot liquid).

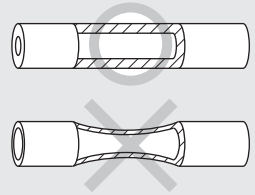

## Plumbing layout

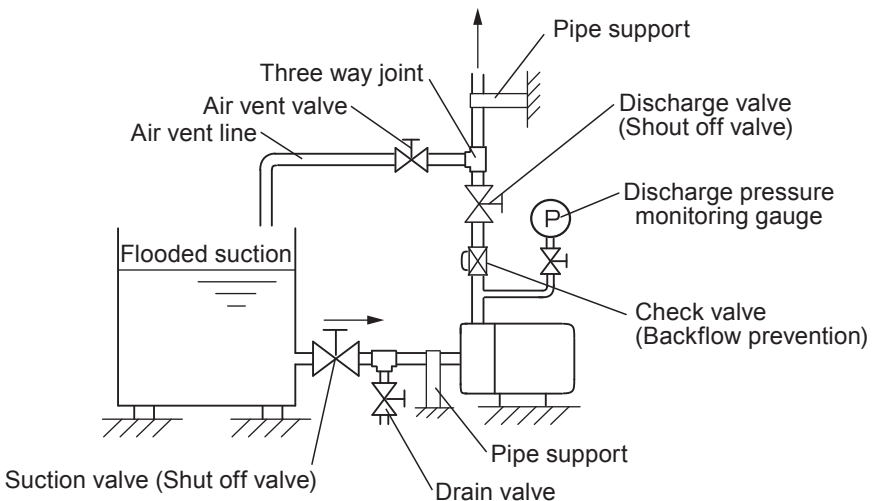

### ■ Discharge & Suction valves

Install a ball valve on a discharge line for the adjustment of a flow rate/delivery head or shutting off a flow, and on a suction line for the convenience of maintenance or shutting off a flow, as close to the pump as possible.

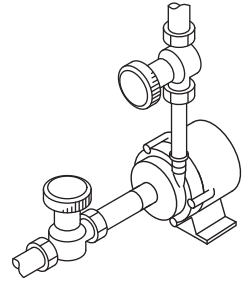

### ■ Pressure gauge

Install a pressure gauge for monitoring discharge line pressure.

### ■ Drain valve

Install a drain valve in between the pump inlet and a suction valve for blowing down liquid.

## ***Plumbing***

---

### **Tube**

#### **1** Cut the tube end flat.

Select a tube in accordance with the inlet and outlet of the pump. Connection will not be secured if a different size tube is used.

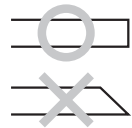

#### **2** Connect tube into the pump inlet.

First slide an applicable screw/band tube clamp onto a tube. Then push a tube end into an inlet or outlet until it bottoms out.

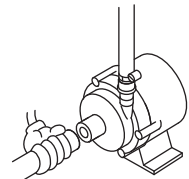

### 3 Clamp down connection.

Be sure to secure the tube connection with a clamp to eliminate the possibility of leakage.

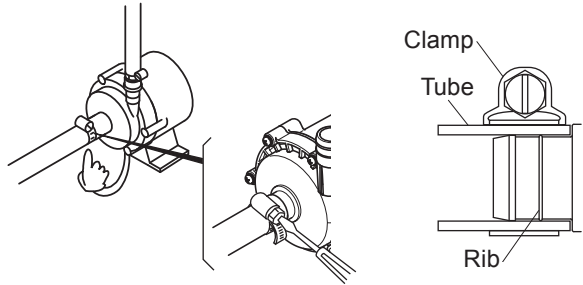

#### NOTE

- The pump inlet and outlet are plastics. Do not use excessive force.
- Always use a screw/band tube clamp. Do not use wire clamp.

## Pipe

### 1 Connect to plastic thread pipe.

The inlet and outlet of the pump are made of plastics. They must be connected to plastic thread pipes. Using metal pipes, these plastics parts will break.

### 2 Apply thread sealing tape.

Wrap a sealing tape two to three turns to the inlet and outlet of the pump. Do not wrap too many times unnecessarily, otherwise the connection may break.

#### NOTE

Do not use a liquid sealant. A liquid sealant can deteriorate the plastic connection.

### 3 Plumb the pump.



Always hold the pump head while screwing in pipes. Tightening torque is  $4\text{N}\cdot\text{m}$ . Avoid holding the motor unit, or excessive force may be applied to the connection point between the pump head and the motor.

# Plumbing precautions

## ■ Suction line

- In order to minimize plumbing resistance, have plumbing shortest with the minimum bends. Note cavitation\* tends to occur when plumbing length is too long.
- A liquid level should be at least 30cm higher than the tank outlet for the prevention of air ingress.
- Keep liquid in a supply tank free from foreign matters. Clean the tank at intervals.
- Avoid any loops in a plumbing run that could form a vapour trap. A suction line should be laid on a rising gradient of 1/100 toward the pump so as to expel air easily.
- Be sure to secure connections on a suction line for the prevention of entrained air. The presence of air in a suction line may prevent liquid delivery.
- Do not use a suction tube, pipe or coupler with a smaller I.D. than the pump inlet.

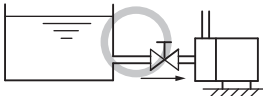
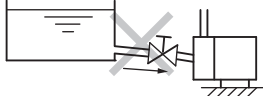
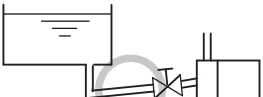
## Suction line examples

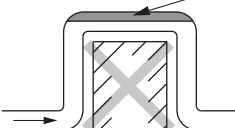
Acceptable	Unacceptable
 <p>Flooded suction</p>	 <p>Descending gradient</p>
 <p>Ascending gradient</p>	 <p>Suction lift</p>
 <p>U-shaped piping</p>	 <p>Air trap</p> <p>Arched piping</p>

## Glossary

### Cavitation

Air bubbles caused by a negative pressure in the pump unit, accompanied with vibration and noise. Performance deterioration or part corrosion results.

## ■ Discharge line

- Use measures to keep the pump connections free from stress. Weight and thermal expansion/contraction of the piping can stress connection points.
- The longer the plumbing length, the more pipe resistance. If the plumbing length is long, widen the pipe I.D. accordingly to reduce the pipe resistance and ensure the rated pump performance is kept.
- Liquid in the pump and plumbing may freeze and consequently cause damage at a freezing temperature. Drain or flush the pump and plumbing before leaving them for a long period.

*Wiring for power source, earthing and external signal.*

## **!** Observe the following points

- Electrical work should be performed by a qualified electrician. Conform to local electric codes.
- Risk of electrical shock. Be sure to turn off power to stop the pump and related devices before service is performed. Or an electrical shock or short circuit may result.
- Be careful for power not to be turned on during work.

## **Power & External signal cables**

### ■ Before wiring

- Check that the main power is turned off.
- Electrical work should be performed in accordance with local electric codes, with an appropriate wire gauge or so.
- Apply the rated power voltage. See the spec label.
- The pump doesn't have an ON-OFF switch. The pump starts as a power cable is plugged in. Do not turn ON and OFF power in a short time.
- When an external fuse is used and it has tripped, always solve the root cause of blowout. Be sure to unplug the pump before investigation. If the fuse blows frequently, the starting current may be a root cause.
- Check power voltage has reduced to 0V before turning on power, especially right after operation. Otherwise, the pump may not start to run.
- Use a DC power supply that assures voltage increment to 24VDC within 50ms. If it takes more than 50ms, the pump may not start to run.
- In order to make the ON-OFF operation, install the switch between the DC power supply and the pump. Installing it between the DC power supply and the AC power supply, the pump may not run.



Wiring example

- After wiring is made, check that peripheral devices in your system are free from the inductive noise at start-up in advance.
- Noise accompanies the high-speed switching of the drive circuit in the pump. Check it does not affect peripheral devices in your system in advance.
- If the DC power supply is shared with the inductive loads such as solenoid and relay, take protective measures against surge.
- The 1-5VDC external variable signal is used for just a simple flow control, and a flow rate is not even in proportion to the signal voltage. When better controllability is required, install a flow sensor to establish the feedback control system.

■ **Rated current & Starting current**

Model	Rated current	Starting current
RD-40	5.5A	10A
RD-40X	5.3A	10A

# Wiring examples

A 500mm option cable is available.

## ■ Specification (connector)

Model	Pin alignment			Receptacle	SUMIKO TEC applicable connector		Applicable lead wire
	1	2	3		F housing CL07D03A	Terminal 215004-2M	
RD-40/-40X	External variable signal (+)*	Power (+)	Power (-)	M housing CL07E03M	F housing CL07D03A	Terminal 215004-2M	AWG#20 UL3266

\*The power voltage (-) is common to the external variable signal (-).

\*The external variable signal should not exceed 25.2VDC.

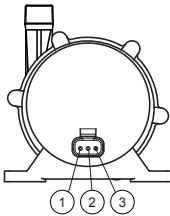

Motor back

## NOTE

Observe polarity, otherwise failure or malfunction may result. Note that rotational direction of the motor does not change by reversing polarity.

## ■ Wiring diagram (option cable)

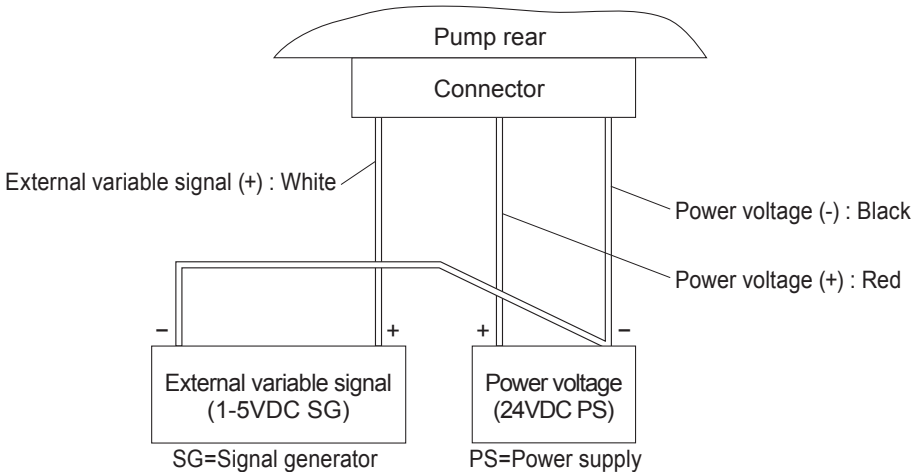

■ **Wiring diagram (with no 1-5VDC signal generator)**

The pump is able to run with no 1-5VDC signal generator when electrically wired as follows. In this case the pump runs at the maximum speed.

Model	Pin alignment		
	1	2	3
RD-40/-40X	Power (+)	Power (+)	Power (-)

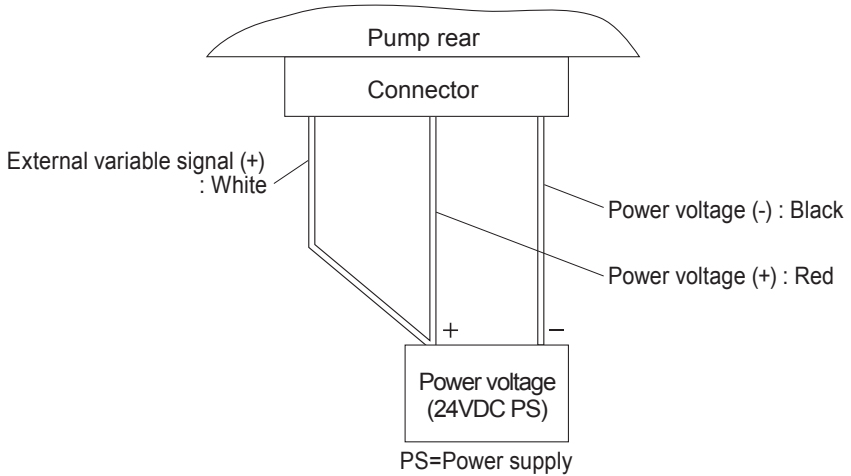
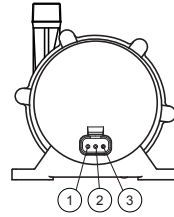

# Operation

**The pump becomes ready after pipework and wiring is completed.**

## **!** Observe the following points

- Do not operate the pump with a suction valve (gate valve) closed. Otherwise, the internal parts of the pump will be damaged.
- For the prevention of water hammer, close a discharge valve completely at the start of operation and then gradually open the valve as discharge pressure increases.
- Do not close a discharge line during operation. Or liquid temperature rise may damage the pump.
- Risk of scald injury. The surface temperatures of the pump and pipe rise high along with liquid temperature. Do not touch the pump or pipe surface directly in or right after operation.

## Pump operation

### Start-up

No.	Procedure	Points to be checked
1	Check plumbing, wiring and power voltage.	<ul style="list-style-type: none"><li>• See "Pipework" and "Wiring" sections.</li><li>• Check the spec label for specified supply voltage.</li></ul>
2	Clean the inside of tubing/piping and tank. Then prime the pump.	<ul style="list-style-type: none"><li>• Do not allow foreign matters to enter the pump.</li></ul>
3	Open a valve.	<ul style="list-style-type: none"><li>• Fully open a suction valve.</li><li>• Fully close a discharge valve.</li><li>• Close an air vent valve as necessary.</li></ul>
4	Supply the main power and send the external variable signal.	<ul style="list-style-type: none"><li>• The pump may not start to run if the signal is less than 3VDC, because starting torque is too low and subsequently the internal protective circuit locks the motor. In this case, increase the signal to 3VDC or more to run the motor and then reduce to a target value.</li><li>• The minimum starting voltage changes with plumbing, liquid property and other operating conditions.</li></ul>
5	Open a discharge valve to adjust a flow to a specified level.	<ul style="list-style-type: none"><li>• Open a discharge valve slowly to meet a duty point. Do not rotate the valve sharply.</li><li>• Observe the minimum flow rate (a tenth of the max flow rate). Operation below that flow rate builds up friction heat to a break down if it continues more than 1 minute.</li><li>• Turn off power if operation is upset, see page 27.</li></ul>

No.	Procedure	Points to be checked
6	Expel air from the pump.	<ul style="list-style-type: none"> <li>• Air may not be expelled well if plumbing resistance is too high. Install air vent line as necessary.</li> <li>• Completely expel air from the pump. Or the bearing will be badly worn.</li> <li>• Keep the discharge line resistance to 1m or below and repeat 15-second operation about 5 times.</li> </ul>
7	Check the operation	<ul style="list-style-type: none"> <li>• Do not allow foreign matters to enter the pump. Foreign matters may cause the impeller to be locked, hindering liquid circulation. In this case turn off power immediately and contact us.</li> <li>• Turn off power when the fuse has blown. Investigate a root cause according to the troubleshooting section of page 27.</li> </ul>

## NOTE

Turn off power immediately at system upset. See page 27 for troubleshooting.

## Shutdown

### **!** Observe the following points

- Liquid in the pump and plumbing may freeze and consequently cause damage at a freezing temperature. Drain or flush the pump and plumbing before leaving them for a long period.
- Use a heater to prevent liquid from freezing when the pump is temporarily stopped at a freezing temperature.
- In case a blackout interrupts the pump operation, switch off the pump and close a discharge valve.

No.	Procedure	Points to be checked
1	Close a discharge valve slowly.	<ul style="list-style-type: none"> <li>• Do not cause sudden closure by using a solenoid valve, or pump may be damaged.</li> </ul>
2	Stop the external variable signal. And then turn off main power.	<ul style="list-style-type: none"> <li>• The pump does not always stop at the same voltage level of the external variable signal as it is reduced. It varies with plumbing, power spec and other operating conditions.</li> <li>• When phasing down the voltage level, the pump may stop before a signal level falls below 1VDC. In this case, the motor may still be charged. Be sure to reduce the signal level to 0VDC before turning off main power.</li> <li>• Follow the Start-up procedure every time the pump is run. If the pump does not run, inspect the pump.</li> </ul>

# Maintenance

**Troubleshooting, inspection, wear part replacement, exploded views and specifications are described in this section.**

## Troubleshooting

*Handling of the pump, maintenance and inspection should be carried out within this instruction manual. Do not go beyond the descriptions in this manual.*

*It is not the manufacturer's responsibility for personal injury or property damage resulting from unauthorized service. Contact us or your nearest distributor as necessary.*

States	Possible causes	Solutions
Abnormal heat	A motor has locked up or a circuit has failed.	Contact us.
	Specific gravity or viscosity is too high.	Replace with a suitable pump.
	Liquid and ambient temperature are out of spec.	Contact us.
Pump does not run.	Wrong wiring	Inspect wiring. Rewire as necessary.
	A motor has locked up or a circuit has failed.	Contact us.
	Specific gravity or viscosity is too high.	Replace with a suitable pump.
	Power capacity shortage	Check power capacity.
	Frequent ON-OFF	Do not make a frequent ON-OFF. See page 13.
Delivery head is too low.	Air trap in the pump	Expel air.
	Entrained air from a suction line	Check the line.
	Dry running	Check for possibility of dry running before operation.
	Specific gravity or viscosity is too high.	Replace with a suitable pump.
	Pump head mounting screws are loose.	Tighten the mounting screws by 1.6 N•m.

Over current	Wrong wiring	Inspect wiring. Rewire as necessary.
	A motor has locked up or a circuit has failed.	Contact us.
	Dry running	Check for possibility of dry running before operation.
	Specific gravity or viscosity is too high.	Replace with a suitable pump.
Significant noise and vibration	A motor has locked up or a circuit has failed.	Contact us.
	Air trap in the pump	Expel air.
	Dry running	Check for possibility of dry running before operation.
Leakage	Pump head mounting screws are loose.	Tighten the mounting screws by 1.6 N•m.

### ***Retightening of pump head fixing screws***

---

*After a long period of operation or storage, the pump head mounting screws may come loose. Tighten the mounting screws by 1.6N•m as necessary.*

*Do not use excess force. The plastic pump head may deform.*

## Drainage

No drain port is provided to this pump. See drainage procedure below.

### ! Observe the following points

- Turn off power before drainage.
- Always wear protective clothing such as an eye protection, chemical resistant gloves, a mask and a face shield during disassembly, assembly or maintenance work. The specific solution will dictate the degree of protection. Refer to MSDS precautions from the solution supplier.
- Solution in the discharge line may be under pressure. Release the pressure from the discharge line before disconnecting plumbing or disassembly of the pump to avoid solution spray.
- Do not drain chemical liquids directly on the ground or the floor. Dispose of chemicals in accordance with local rules and regulations.
- The pump is not waterproof. Do not operate the pump while wet with solution or water. Failure or injury may result. Immediately dry off the pump if it gets wet.
- Dilute and flush out harmful liquid before removing a tube or a pipe.

## Blowdown

### 1 Turn off power.

Make sure no one turns on power by mistake in service.

### 2 Close both the discharge and suction valves.

Use a drain valve if it is equipped on a suction line. Note some amount of liquid will remain in the pump.

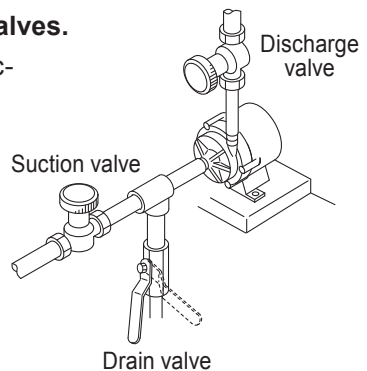

**3 Remove tubes or pipes from the inlet and outlet.**

Collect residual liquid from plumbing in a container.

NOTE

Do not get wet with dripping residual liquid.

**4 Remove anchoring bolts and release the pump.**

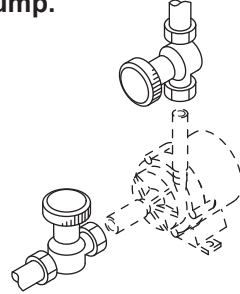

**5 Direct the inlet downwards to run off liquid in the container.**

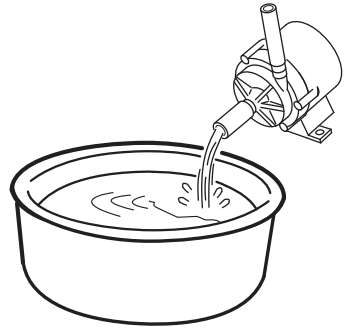

## Inspection

Perform daily and periodic inspections to keep pump performance and safety.

### **Daily inspection**

---

Check the following points. If you notice any abnormal or dangerous conditions, suspend operation immediately and inspect/solve problems according to the troubleshooting section. If it does not help removing problems, contact us or your nearest distributor. Do not disassemble the pump.

No.	States	Points to be checked	How to check
1	Evidence of a leak	<ul style="list-style-type: none"><li>• Check for a leak. Do not start operation with a leak.</li></ul>	Visual
2	Pumping	<ul style="list-style-type: none"><li>• If liquid is pumped.</li></ul>	Flow meter or visual inspection
		<ul style="list-style-type: none"><li>• If the suction and discharge pressure are normal.</li></ul>	Check specification.
		<ul style="list-style-type: none"><li>• If a liquid level in a supply tank is proper.</li></ul>	Visual
		<ul style="list-style-type: none"><li>• If liquid is deteriorated, crystallized or settled.</li></ul>	Visual or audio inspection
3	Noise and vibration	<ul style="list-style-type: none"><li>• If abnormal noise or vibration occurs. They are signs of abnormal operation.</li></ul>	Visual or audio inspection
4	Air ingress from pump head joints and a suction line	<ul style="list-style-type: none"><li>• If discharge liquid includes air bubbles, check lines for a leak and retighten as necessary.</li></ul>	Visual or audio inspection
5	Load to the pump	<ul style="list-style-type: none"><li>• If discharge pressure and current are normal.</li></ul>	See the motor spec label.
6	Performance specification	<ul style="list-style-type: none"><li>• If discharge pressure, a flow rate or load current fluctuates. If so, see the troubleshooting section.</li></ul>	See the performance specification.

## Specification/Outer dimension

### Specification

Model code	Connections		Max flow	Max head	Max noise	Max SG	Motor		Weight
	Inlet	Outlet					Power voltage	Rated output	
RD-40	ø26mm	ø19mm	25L/min	15m	55dB	1.0	24VDC	85W	1.5kg
	R1"	R1/2"							
	NPT1"	NPT1/2"							
RD-40X	ø26mm	ø26mm	70L/min	8m	55dB	1.0	24VDC	72W	1.5kg
	R1"	R3/4"							
	NPT1"	NPT3/4"							

\*This data is based on pumping clean water at ambient temperature.

\*The maximum flow rate could be obtained if a delivery head was 0m. The maximum head could be obtained if a flow rate was 0 L/min.

\*The maximum viscosity is 1mPa\*s when specific gravity is 1.0.

\*Allowable ambient temperature: 0-40°C

\*Allowable ambient humidity: 35-90%RH

\*Allowable liquid temperature: 0-80°C

\*The ambient temperature/humidity and liquid temperature range may change with operating conditions such as development of heat cycle (do not use the prohibited liquid on page 13).

\*Motor type: The RD-40/-40X are equipped with a BLDC motor and its drive circuit provides the following protections.

**a. Pump lock protection**

A speed detector monitors the impeller speed. The motor stops when it is upset by foreign matters.

**b. Heat protection**

The pump stops when the motor temperature becomes extremely high due to sharp ambient or liquid temperature rise or overload operation.

After the pump lock protection or heat protection are activated, solve root causes before resuming operation. The pump restarts when power is turned on.

**c. Overcurrent limiting control circuit**

Drive elements are protected from the starting current and excessive current.

**d. Fuse**

A fuse is equipped in driving circuit in order to protect other equipment or to prevent a fire which may occur when an internal circuit is damaged.

The built-in fuse can not be replaced. Installation of an external fuse is recommended.

\*The data above and dimensions may be changed without prior notice.

# Outer dimensions

## ■ RD-40/-40X

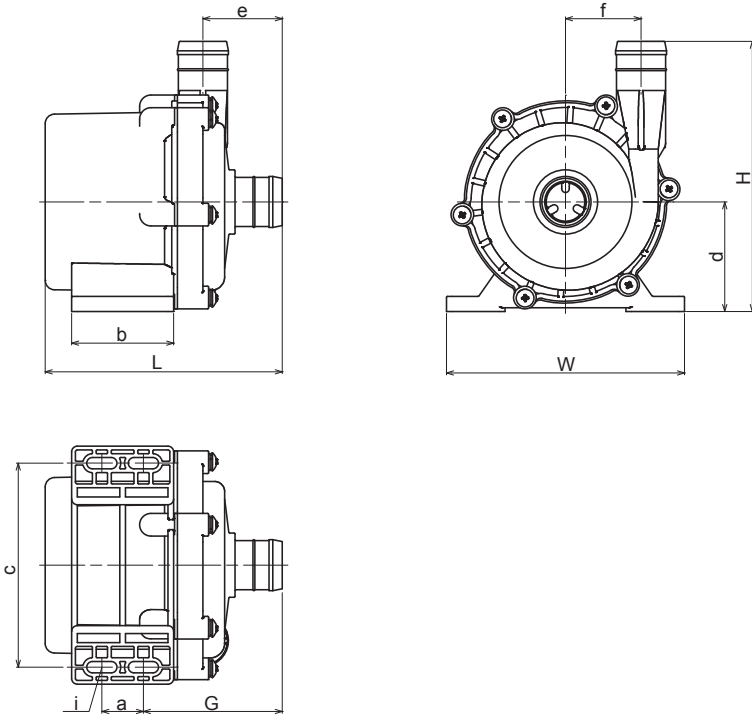

Unit (mm)

Model	Connection	W	H	L	a	b	c	d	e	f	G	I
RD-40	Tube	126	(139)	(127)	22	54	108	(58)	42	37	(75)	4-16×6
	R pipe thread	126	(133)	(127)	22	54	108	(58)	42	37	(75)	4-16×6
	NPT pipe thread	126	(133)	(127)	22	54	108	(58)	42	37	(75)	4-16×6
RD-40X	Tube	126	(143)	(127)	22	54	108	(58)	42	40	(75)	4-16×6
	R pipe thread	126	(134)	(127)	22	54	108	(58)	42	40	(75)	4-16×6
	NPT pipe thread	126	(134)	(127)	22	54	108	(58)	42	40	(75)	4-16×6

# Performance curves

## ■ RD-40

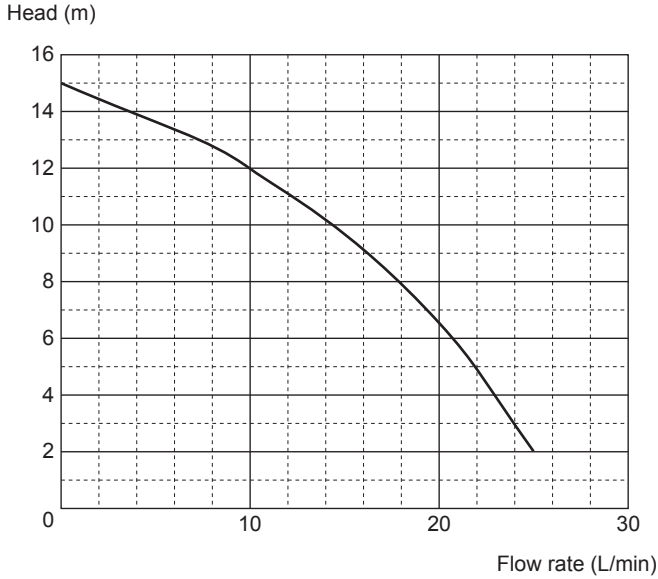

\*Observe the maximum flow rate of 25L/min. Cavitation may be developed beyond that rate.

## ■ RD-40X

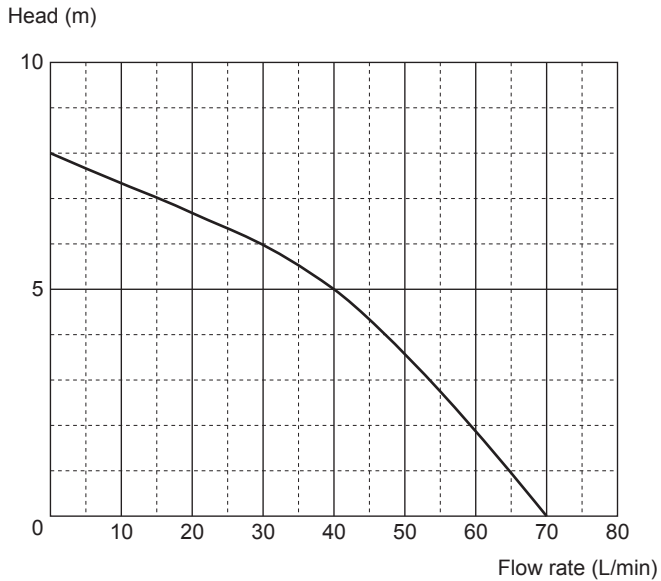

## Part names & Structure

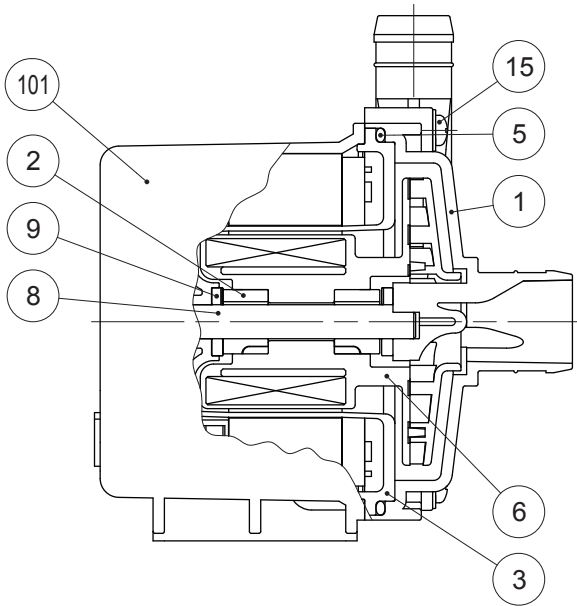

No.	Part names	Q'ty	Materials
1	Front casing	1	PPS
2	Bearing	2	Filled PTFE
3	Rear casing	1	PPS
5	O ring	1	EPDM
6	Impeller	1	PPS
8	Spindle	1	Alumina ceramic
9	Thrust ring	2	Alumina ceramic
15	Machine screw w/ PW & SW	6	Stainless steel
101	Motor	1	

# EC DECLARATION OF CONFORMITY

A copy of the original Declaration of Conformity

(SUPPLIER'S NAME)

WE

IWAKI CO.,LTD.

(ADDRESS)

6-6 2-CHOME KANDA-SUDACHO CHIYODA-KU TOKYO JAPAN

(PRODUCT)

DECLARE UNDER OUR SOLE RESPONSIBILITY THAT THE PRODUCTS  
DIRECT DRIVE PUMP

(MODEL NAME)

RD-40/40X SERIES

TO WHICH THIS DECLARATION RELATES ARE IN CONFORMITY  
WITH THE FOLLOWING STANDARDS OR DIRECTIVES AS FAR AS APPLICABLE

(DIRECTIVES)

MACHINERY DIRECTIVE 2006/42/EC (ANNEX IIA)  
EMC DIRECTIVE 2014/30/EU  
RoHS DIRECTIVE 2011/65/EU

(STANDARDS)

EN ISO12100:2010      EN61000-6-2:2005      EN IEC63000:2018  
EN809:1998+A1:2009      EN61000-6-4:2007+A1:2011

(A PERSON WHO IS AUTHORISED TO COMPILE THE TECHNICAL FILE  
IN THE COMMUNITY)

IWAKI EUROPE GMBH  
SIEMENSRING 115 D-47877 WILLICH GERMANY

NOTE: THIS DECLARATION BECOMES INVALID IF TECHNICAL OR OPERATIONAL  
MODIFICATIONS ARE INTRODUCED WITHOUT THE MANUFACTURER'S  
CONSENT.



TSUTOMU SAWADA

DEPUTY SENIOR GENERAL MANAGER,

QUALITY ASSURANCE HEAD OFFICE

Tokyo, Sep. 13, 2021

(PLACE AND DATE OF ISSUE)

(NAME AND SIGNATURE OR EQUIVALENT MARKING OF AUTHORIZED PERSON)

DOCUMENT NO. IS-51K-444-4







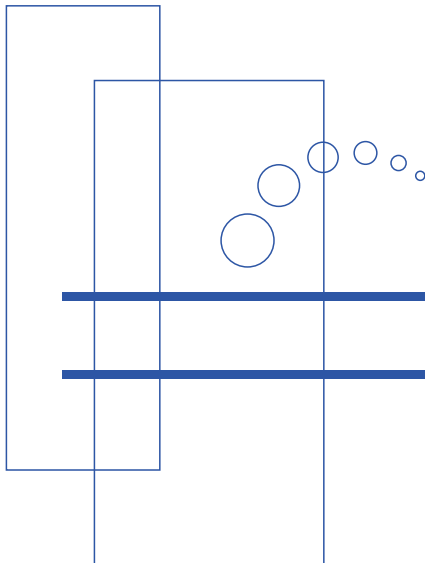

<https://www.iwakipumps.jp>

IWAKI CO.,LTD. 6-6 Kanda-Sudacho 2-chome Chiyoda-ku Tokyo 101-8558 Japan  
TEL: +81 3 3254 2935 FAX: +81 3 3252 8892

**European office** / IWAKI Europe GmbH  
TEL: +49 2154 9254 0 FAX: +49 2154 9254 48

**Germany** / IWAKI Europe GmbH  
TEL: +49 2154 9254 50 FAX: +49 2154 9254 55

**Holland** / IWAKI Europe GmbH (Netherlands Branch)  
TEL: +31 74 2420011 FAX: +49 2154 9254 48

**Italy** / IWAKI Europe GmbH (Italy Branch)  
TEL: +39 0444 371115 FAX: +39 0444 335350

**Spain** / IWAKI Europe GmbH (Spain Branch)  
TEL/FAX: +34 934 741 638

**Poland** / IWAKI Europe Branch EAST  
TEL: +48 12 347 0755 FAX: +48 12 347 0900

**Belgium** / IWAKI Belgium N.V.  
TEL: +32 13 670200 FAX: +32 13 672030

**Denmark** / IWAKI Nordic A/S  
TEL: +45 48 242345

**Finland** / IWAKI Suomi Oy  
TEL: +358 10 201 0490

**France** / IWAKI France S.A.  
TEL: +33 1 69 63 33 70 FAX: +33 1 64 49 92 73

**Norway** / IWAKI Norge AS  
TEL: +47 23 38 49 00

**Sweden** / IWAKI Sverige AB  
TEL: +46 8 511 72900

**U.S.A.** / IWAKI America Inc.  
TEL: +1 508 429 1440 FAX: +1 508 429 1386

**Argentina** / IWAKI America Inc. (Argentina Branch)  
TEL: +54 11 4745 4116

**Brazil** / IWAKI Do Brasil Comercio De Bombas Hidraulicas LTDA  
TEL/FAX: +55 19 3244 5900

**Singapore** / IWAKI Singapore Pte Ltd.  
TEL: +65 6316 2028 FAX: +65 6316 3221

**Indonesia** / IWAKI Singapore (Indonesia Office)  
TEL: +62 21 6906606 FAX: +62 21 6906612

**Malaysia** / IWAKIm SDN. BHD.  
TEL: +60 3 7803 8807 FAX: +60 3 7803 4800

**Australia** / IWAKI Pumps Australia Pty Ltd.  
TEL: +61 2 9899 2411 FAX: +61 2 9899 2421

**China** (Hong Kong) / IWAKI Pumps Co., Ltd.  
TEL: +852 2607 1168 FAX: +852 2607 1000

**China** (Guangzhou) / GFTZ IWAKI Engineering & Trading Co., Ltd.  
TEL: +86 20 84350603 FAX: +86 20 84359181

**China** / IWAKI Pumps (Shanghai) Co., Ltd.  
TEL: +86 21 6272 7502 FAX: +86 21 6272 6929

**Korea** / IWAKI Korea Co., Ltd.  
TEL: +82 2 2630 4800 FAX: +82 2 2630 4801

**Taiwan** / IWAKI Pumps Taiwan Co., Ltd.  
TEL: +886 2 8227 6900 FAX: +886 2 8227 6818

**Thailand** / IWAKI (Thailand) Co., Ltd.  
TEL: +66 2 322 2471 FAX: +66 2 322 2477