

IWAKI
Electromagnetic Metering Pump

EH-E Type

Instruction Manual

⚠ Read this manual before use of product

Thank you for choosing an Iwaki's EH-E Series metering pump. This instruction manual deals with the correct installation, operation, maintenance, and troubleshooting procedures for the EH-E model metering pump. Please read through it carefully to ensure the optimum performance, safety and service of your pump.



Contents

IMPORTANT INSTRUCTION	-----1
Safety Section	-----2
1.INTRODUCTION	-----5
1.Unpacking	-----6
2.Operation Principle	-----6
3.Specifications	-----7
4.Dimensions	-----10
2.INSTALLATION	-----14
1.Before Use	-----15
2.Location	-----16
3.Supply Tubing	-----16
4.Discharge Tubing	-----17
5.Electrical	-----17
3.OPERATION	-----18
1.Priming	-----19
2.Adjustment	-----20
3.Calibration	-----20
4.External Control	
4,1Display/Keypad and Wiring Overview	-----21
4,2 Quick Reference	-----22
4,3 Digital Mode	-----25
4,4 Analog Mode / STOP Function	-----26
4,5 AC Power Interruption	-----28
5.MAINTENANCE	-----29
1.Maintenance	-----30
2.Diaphragm Replacement	-----30
3.Valve Replacement	-----30
4.Tubing	-----30
5.Names of Part and Structure	-----31
6.Troubleshooting	-----35
1.Troubleshooting	-----36

Important Instruction

For the Safe and Correct Handling of the Pump

- Read the "Safety Instructions" sections carefully to prevent accidents involving your customers or other personnel and to avoid damage or loss of other assets. Always follow the instructions and advice found in these sections.
- Observe and abide by the instructions described in this manual. These instructions are very important for protecting pump users from dangerous conditions and situations related with the use of the pump system.
- The symbols relate to the following meanings described below.

 Warning.	Nonobservance or misapplication of the contents of the "Warning" section could lead to a serious accident, including death or injury.
 Caution.	Nonobservance or misapplication of the contents of the "Caution" section could lead to serious physical injury to the user or serious damage to the product.

Types of Symbols



Indicates that "**Warning**" or "**Caution**" must be exercised. Inside this triangle, a concrete and practical image provided as a warning or caution message is depicted.



Indicates a prohibited action or procedure. Inside or near this circle, a concrete and practical image of the activity to be avoided is depicted.



Indicates an important action or procedure which must be performed or carried out without fail. Failure to follow the instructions herein can lead to malfunction or damage to the pump.

Safety Section

Warning.

- **Turn off the power supply**

Working without disconnecting the power supply cause an electrical shock. Before engaging upon any working procedures involving the pump , make sure to turn the power supply switch off and to stop the pump and other related devices.



Electrical shock

- **Terminate operation !**

When you detect or become aware of a dangerous sign or abnormal condition during operation , terminate the operation immediately and start from the beginning again.



- **For specified application only.**

The use of a pump in any application other than those clearly specified may result in injury or damage to the pump . Use the pump strictly in accordance with the pump specifications and application range.



Prohibited

- **No remodeling !**

Never remodel a pump .Otherwise ,a serious accident may result. Iwaki will not be responsible for any accident or damage of any kind which is caused by the user remodeling the pump without first obtaining permission or instructions from Iwaki .



No remodeling

- **Wear protectors.**

If you touch or come in contact with any type of hazardous chemical liquid , including but not limited to chemicals, you may experience a serious injury. Wear protective gear (protective mask, gloves , etc.) during the pump operation.



Wear protective gear









- **Operating site must be free of water and humidity .**

The pump is not designed to be water-proof or dust-proof . The use of the pump in places where water splashes or humidity is high may result in an electrical shock or short circuit.









Prohibited

Safety Section

 Caution.	
<ul style="list-style-type: none"> ● Qualified operators only ! The pump operator and pump operation supervisor must not allow any operators who have little or no knowledge of the pump to run and operate the pump . Pump operators must have a sound knowledge of the pump and its operation. 	 Prohibited
<ul style="list-style-type: none"> ● Specified power only. Do not operate the pump on voltage which is not specified on the nameplate. Failure to do so may result in damage or fire . Only the specified power level is to be applied. 	 Prohibited
<ul style="list-style-type: none"> ● Do not run the pump dry. Do not run the pump dry (without liquid inside the pump). Heat generated as a result of abrasion between elements inside the pump during operation without liquid may damage the inside of the pump. 	 Prohibited
<ul style="list-style-type: none"> ● Do not wet or dampen ! If an electric part or wiring gets wet with the liquid spilled over accidentally , a fire or electrical shock may be caused . Install the system in a place free from liquid spillage or leakage . 	 Do not wet or dampen
<ul style="list-style-type: none"> ● Ventilate ! Poisoning may result during an operation which involves, toxic or odorous liquid. Ventilate the operating site sufficiently. 	 Caution
<ul style="list-style-type: none"> ● Spill-out accident ! Protective measures should be taken against any accidental spill-out or leakage of the operating liquid as a result of unexpected damage on the pump or the related piping. 	 Caution
<ul style="list-style-type: none"> ● Damaged pump Never operate a damaged pump. A damaged pump may cause leakage or electrical shock. 	 Prohibited
<ul style="list-style-type: none"> ● Do not damage or change power cable ! Do not scratch, damage ,process, or pull the power cable forcibly. An extra load onto the cable ,such as heating the cable or placing something heavy on the cable ,may damage the cable and finally cause a fire or an electrical shock. 	 Caution

Safety Section

 Caution.	
<ul style="list-style-type: none"> ● Arrange grounding ! Do not operate the pump without connecting the grounding wire. Otherwise, an electrical shock may result . Make sure the grounding wire is connected with grounding terminal. 	 Grounding
<ul style="list-style-type: none"> ● Install an earth leakage breaker (option) ! The operation of a pump without using an earth leakage breaker may cause an electrical shock . Please purchase an optional leakage breaker and install in the system. 	 Electrical Shock
<ul style="list-style-type: none"> ● Handling of power cable Use of a defective or damaged power cable may result in a fire or electrical shock. Handle the power cable carefully. 	 Electrical Shock
<ul style="list-style-type: none"> ● Follow the instruction manual Replace the consumable part by following the descriptions in the instruction manual .Do not disassemble any part of the pump if the disassembling procedure for the part in question is not included in the instruction manual. 	 Warning
<ul style="list-style-type: none"> ● Limited operating site and storage Do not install or store the pump in the following places : Places where a flammable gas or material is used or stored. Places where the ambient temperature is extremely high(40°C or higher) or extremely low (0°C or lower). 	 Prohibited
<ul style="list-style-type: none"> ● Disposal of used pump Disposal of used or damaged pumps must be done in accordance with the relevant local law and regulations .(Consult a licensed industrial waste products disposing company.) 	 Warning

1.INTRODUCTION

1. <i>Unpacking</i> -----	6
2. <i>Operation Principle</i> -----	6
3. <i>Specifications</i> -----	7
4. <i>Specifications of Control Unit</i> -----	9
5. <i>Dimensions</i> -----	10

1. Unpacking

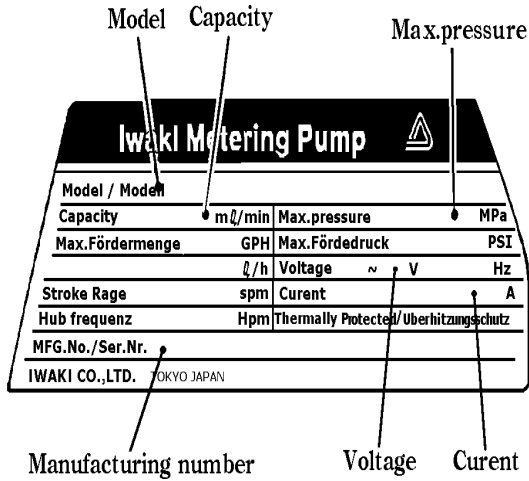

After unpacking the goods, check the following points to ascertain that the product is exactly as you ordered. If you find anything wrong, please get in touch with your dealer.

- (1) Do the model, voltage, etc., shown on the nameplate represent what you ordered?
- (2) Has the goods been damaged in transit? Are the bolts and nuts loose?

2. Operation Principle

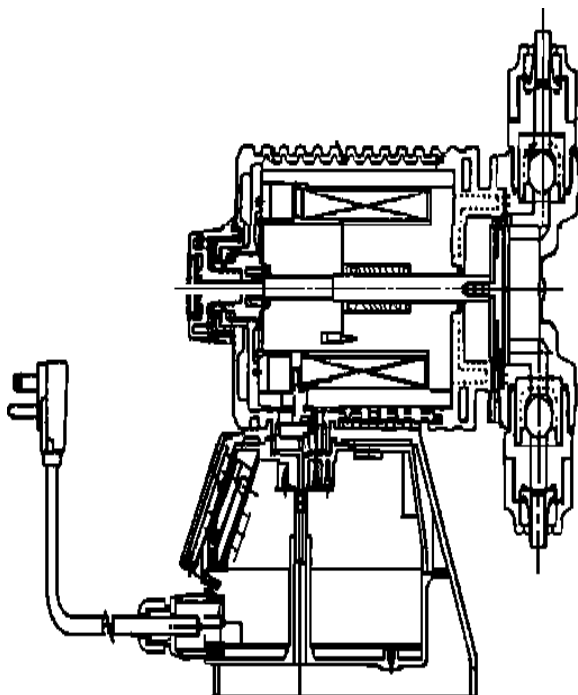

The EH Series electronic metering pump consists of a pump unit, a drive unit, and a control unit. The drive unit is an electromagnetic solenoid. When the solenoid coil is energized by the control unit the armature shaft moves forward due to the magnetic force of the solenoid. The shaft is attached to a PTFE faced diaphragm which is part of the pump unit. The diaphragm is forced into the pump head cavity decreasing volume and increasing pressure which forces liquid in the pump head out through the discharge check valves. When the solenoid coil is de-energized, a spring returns the armature to its starting position. This action pulls the diaphragm out of the head cavity increasing volume and decreasing pressure. Atmospheric pressure then pushes liquid from the supply tank through the suction check valves to refill the pump head.

⑥ Power code

P	with plug
No symbol	without plug

⑦ Controller E : E type

⑧ Connection

Symbol	Applicable hose dia. (ID × OD)	Type
4	φ 8 × φ 13 (mm)	VC,V6,PC,VM
5	φ 9 × φ 12 (mm)	VC,V6,PC,VM
6	φ 10 × φ 12(mm)	FC
8	φ 1/2" × φ 3/8"(inch)	VC,V6,PC,VM,FC
9	Rc 1/4"	SH
10	NPT 1/4"	SH
11	φ 10 × φ 16(mm)	VC,V6,PC,VM
14	Rc 3/8"	SH
15	NPT 3/8"	SH

⑨ Special configuration

01~99: Special material , special connection port diameter , etc.

● Controller identification

<p style="text-align: center;"><u>EHC</u> - <u>100 P E</u> - <u>**</u></p> <p style="text-align: center;">① ② ③④ ⑤</p>					
①	Controller name		EH		
②	Voltage symbol	10 0 11 U 20 J 20 E 23 U	AC100V AC110V,AC115V AC200V AC220V,AC230V,AC240V AC230V	AC 90 ~126V AC 90 ~ 126V AC180 ~ 220V AC198 ~ 264V AC207 ~ 253V	50-60 Hz
③	Lead wire		P: with plug No symbol: without plug		
④	Controller		E		
⑤	Special configuration		0 ~ 99		

Points to be noted in handling

1. Do not detach the control unit unless unavoidable.
2. Never use the control unit with pumps having different symbols for driving unit and power source voltage specified on the control unit. (Check the nameplate.)

 **Caution**

Operation with a pump having different symbols for driving unit and power source voltage other than those specified may cause failure or trouble in the electronic circuit of the control unit or the driving unit of the pump.

● **Pump specifications**

Model	Output capacity (ml/min)	Output per Stroke (ml/stroke)	Maximum Pressure (MPa)	Stroke frequency (spm)	Stroke length % (mm)
E	30	340	0.19~0.94	1	20~100 (0.3~1.5mm)
	35(SH)	520	0.29~1.44	0.7(0.6)	
	45	750	0.42~2.08	0.4	
	55	1250	0.69~3.47	0.2	

Note 1. The performance data is based on clean water at 25°C under rated voltage.

Note 2. Capacity is that at the max. pressure.(at max.stroke length and max.stroke frequency)
Capacity exceeds the value at max.pressure when pump operates under low pressure.

Note 3. Operating ambient temperature : 0 ~ 40°C

Relative humidity : 30% to 90% non-condensing

Note 4. Liquid temperature : PVC/PVDF 0°C ~ 40°C (PC/SH : 0°C ~ 60°C)

Note 5. Permissible voltage fluctuation : Within ±10% of rating

*Please note that for the purpose of improvement,parts which have no effect on specifications and fitting sizes are subject to change without prior notice.

*For SH type, install air chamber of approx. 500 ml volume at the location as close to pump discharge port.

Adjustment Range Recommended stroke length adjustment range 20% to 100%

Recommended frequency adjustment range 0 to 360 stroke per minute

● **Control unit specifications**

Control function	Selection of Function. The function is selected with the operation key.	MAN : Manual control EXT : External signal control (EXT,START/STOP)
Control	Setting	EXT Digital input dividing 1 : n , n=1~999 Digital input counter n : 1 , n=999~1 Analog input DC 4~20 mA ,DC 0~20 mA Analog input DC 20~4 mA ,DC 20~0 mA MAN Stroke rate 0~360spm
	Setting method	Operation 4keys START/STOP,EXT,
	Max spm	Fixed at stroke rate of 360 spm
	Stop(Input stop)	Stopped when contact signal is input.
Display	Data	LCD,4-digit,State of drive,Set value etc.,
	Pump operation	Green LED(Flashes in sync with pump stroke)
Input signal	Pules input	No-voltage contact
	Stop input	No-voltage contact
Output	Sensor power	DC 12V , 10mA
Power supply	AC 100 : AC 90 ~ 110 V , AC110V · AC115V :AC 90 ~ 127V AC 200 : AC 180 ~242 V , AC 230 : AC198 ~264 V	

5. Dimensions (Material symbol: VC/V6/PC/VM/FC)

● EH-E30

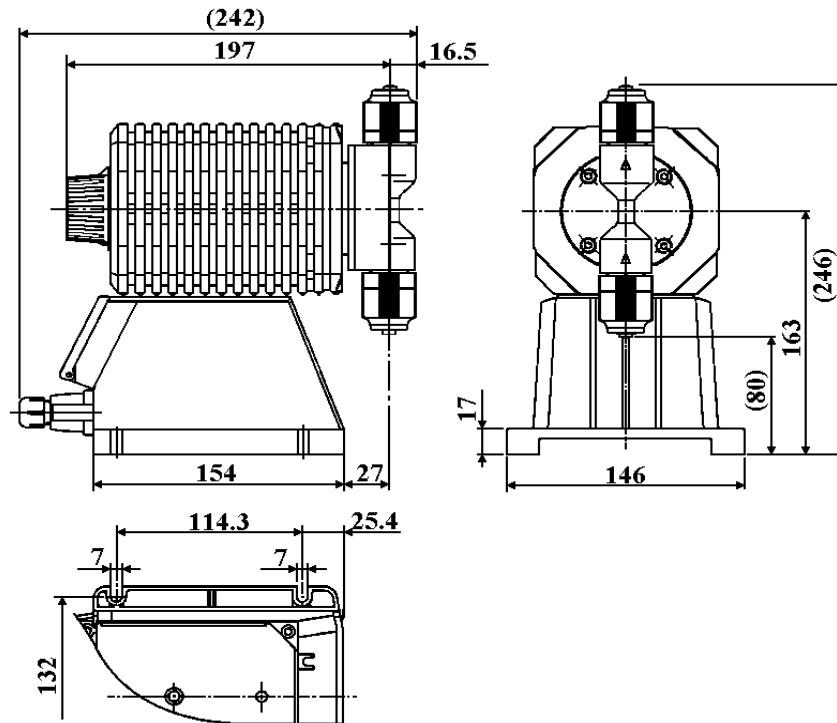

● EH-E35

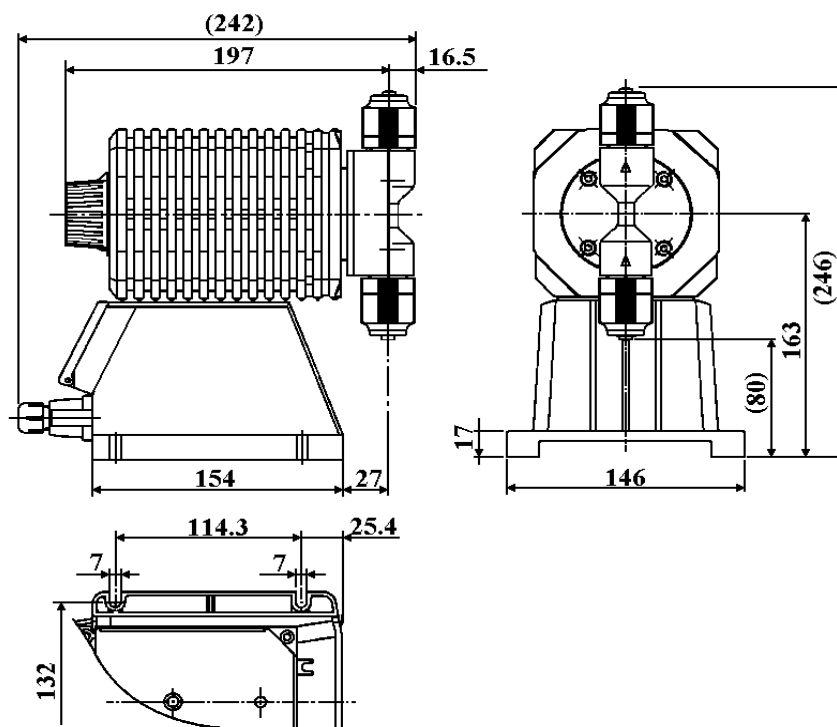

5. Dimensions (Material symbol: VC/V6/PC/VM/FC)

● EH-E45

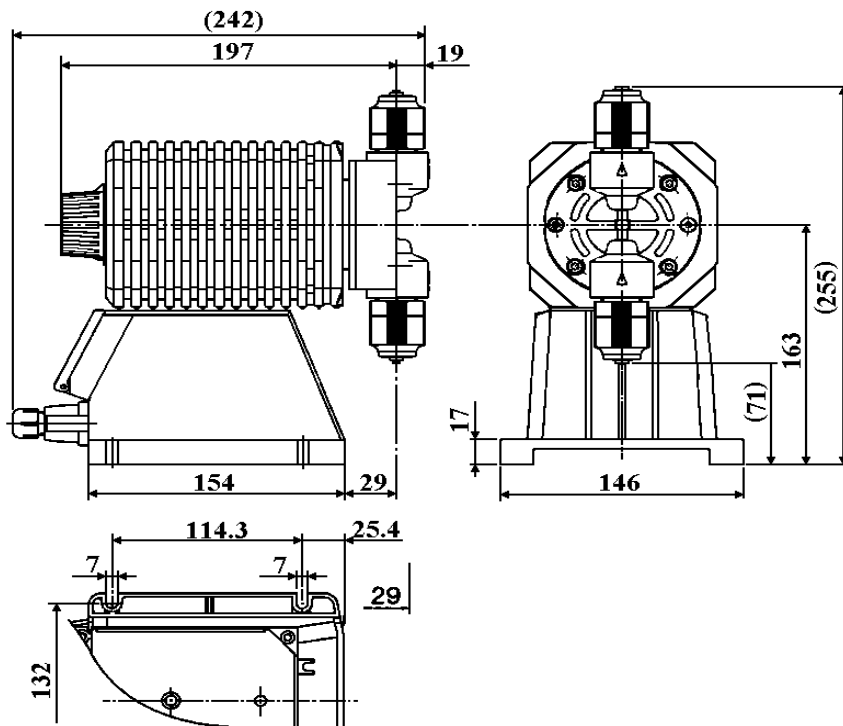

● EH-E55

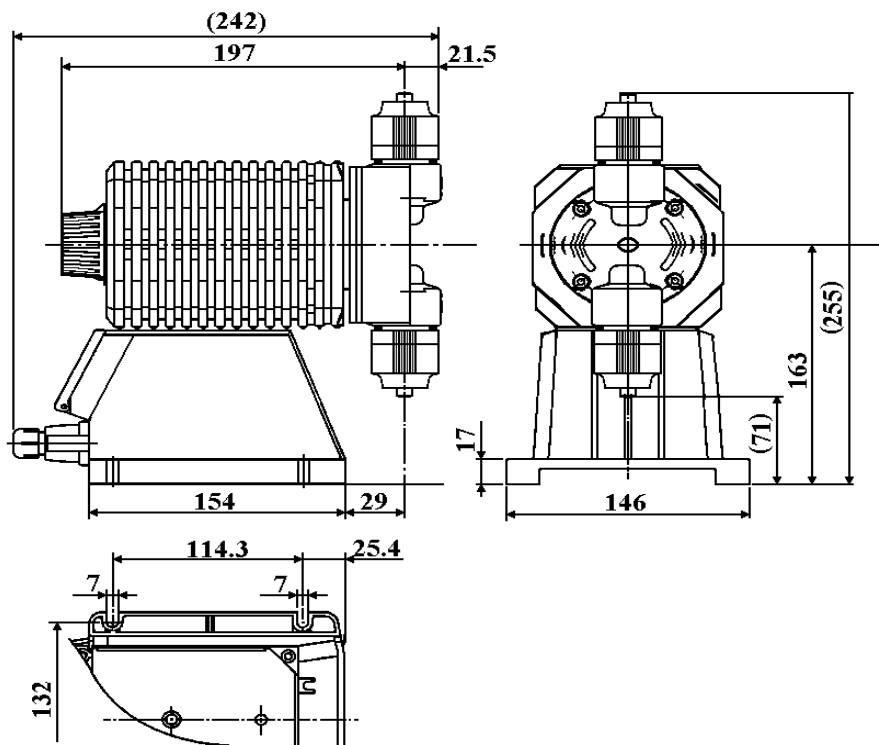

5. Dimensions (Material symbol: SH)

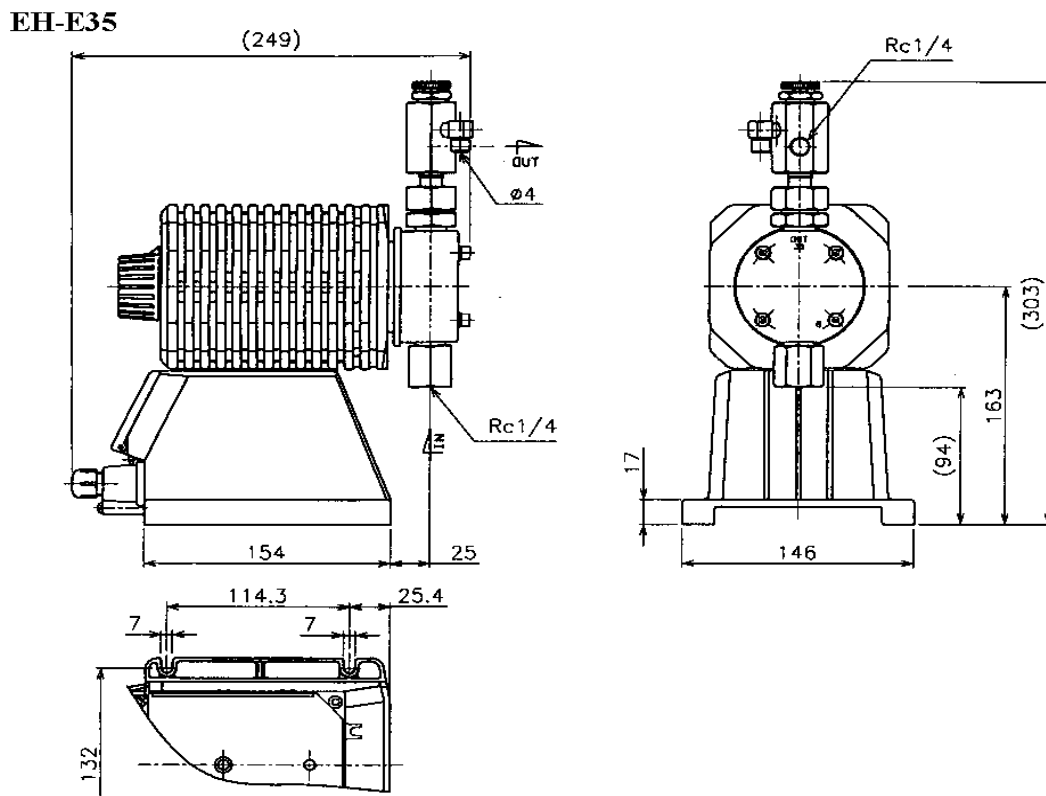
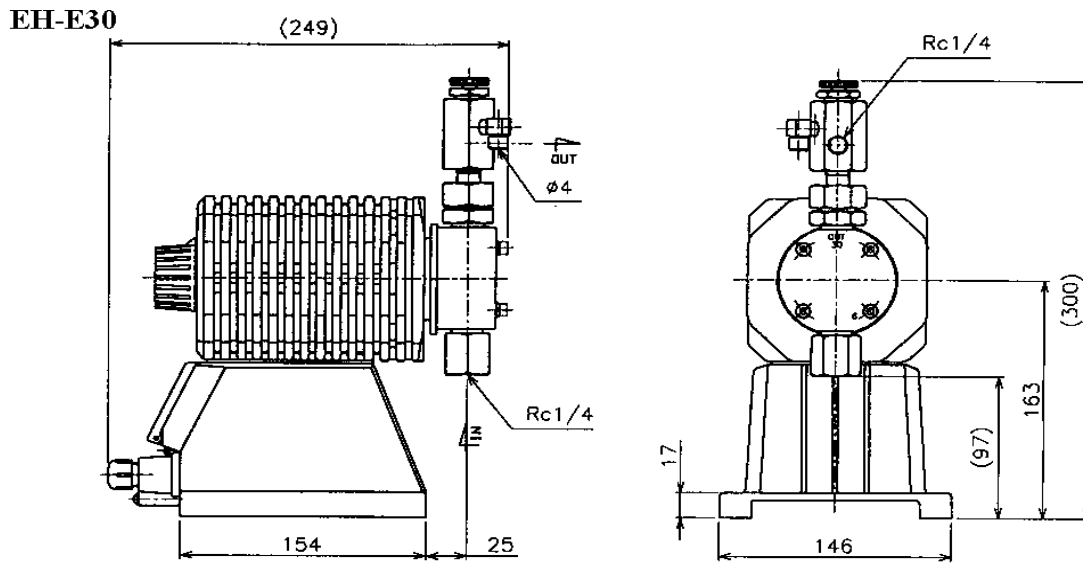

5. Dimensions (Material symbol: SH)

EH-E45

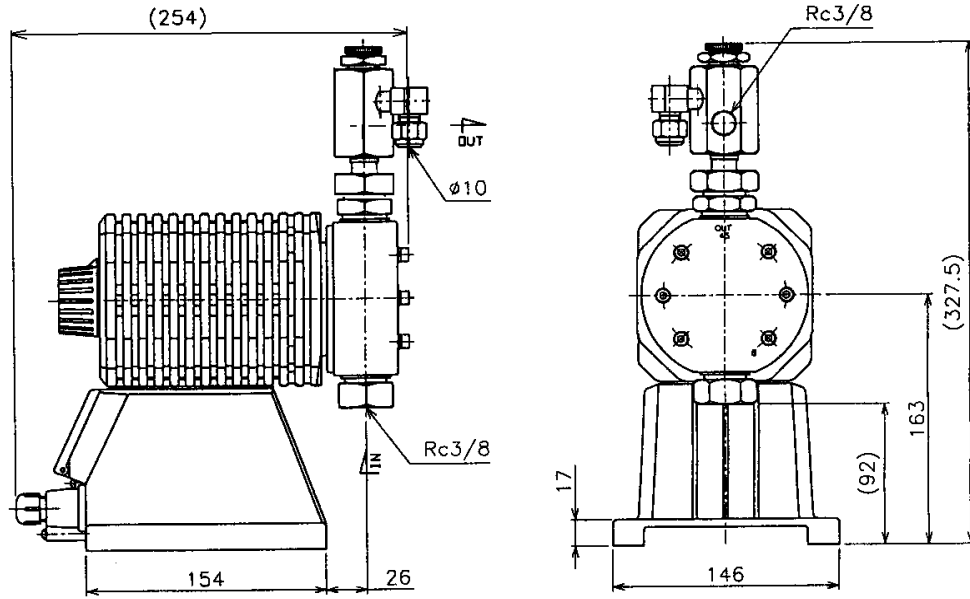

EH-E55

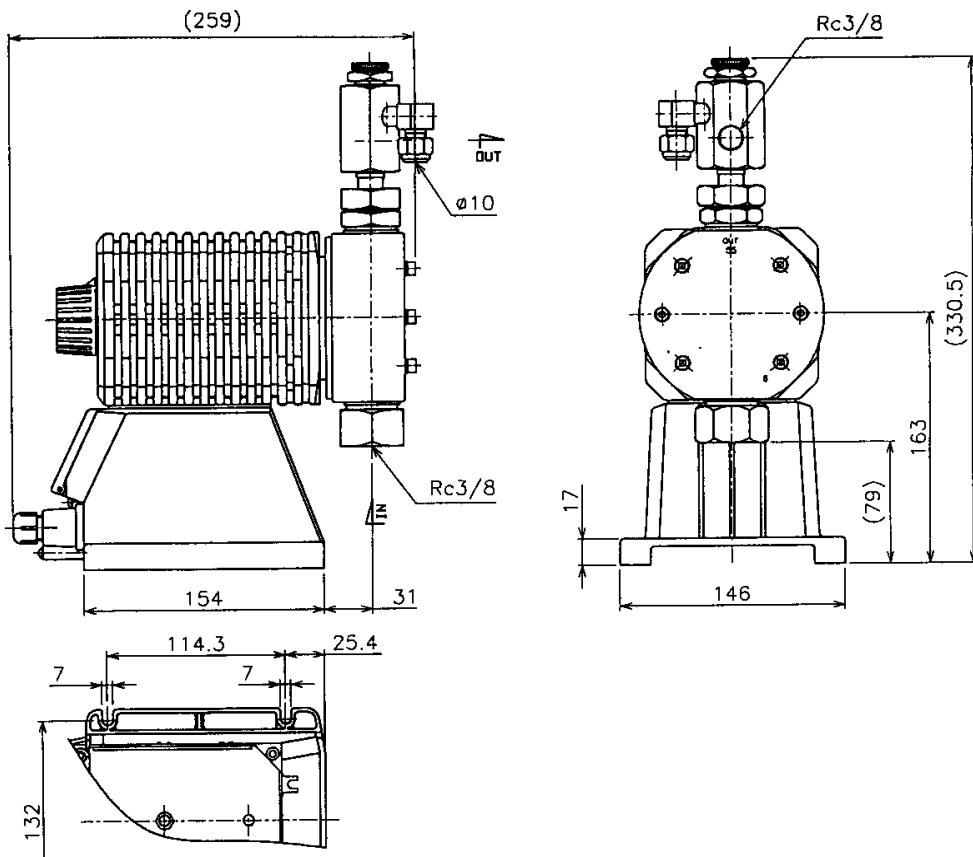

2. INSTALLATION

1. <i>Before Use</i>	-----	15
2. <i>Location</i>	-----	16
3. <i>Suction tubing</i>	-----	16
4. <i>Discharge tubing</i>	-----	17
5. <i>Electrical</i>	-----	17

1. Before Use

Operators and maintenance service staff must read the instruction manual thoroughly before using the products. Do not operate the pump system unless all of the contents in the manual are completely understood.

Caution.

- **Turn off the power supply.**
Working without disconnecting the power supply may cause an electrical shock. Before engaging upon any working procedures involving the pump, make sure to turn the power supply switch off and to stop the pump and other related devices.
- **Terminate operation !**
When you detect or become aware of a dangerous sign or abnormal condition during operation, terminate the operation immediately and start it from the beginning again.
- **Specified power only.**
Do not operate the pump on voltage, which is not specified on the name plate. Failure to do so may result in damage or fire. Only the specified power level is to be applied.
- **Keep from heat or flame.**
Do not place any dangerous materials or flammable objects near the pump for the prevention of fire or accident.
- **Damaged pump**
Never operate a damaged pump. A damaged pump may cause leakage or electrical shock.



1. Dropping the pump or subjecting it to strong impacts may result in faulty performance. Handle the pump with care.

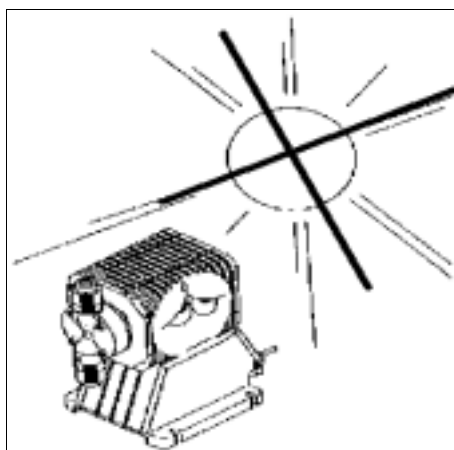

2. When installing the pump, avoid places exposed to direct sunlight or direct rain with an ambient temperature of above 40°C, or with a relative humidity or above 90%. Though the pump has a simple waterproof and dust proof structure, a sheltered location is recommended.

2. Location

Choose a location for the pump which is clean, dry, close to an electrical outlet, and allows convenient access to stroke length control, frequency control, and tubing connections. Avoid areas where ambient temperature exceeds 40°C or falls below 0°C, or where the pump or tubing would be exposed to direct sunlight. Flooded suction (mounting the pump below the level of liquid in the supply tank) is strongly recommended, especially when pumping liquids that readily generate gas

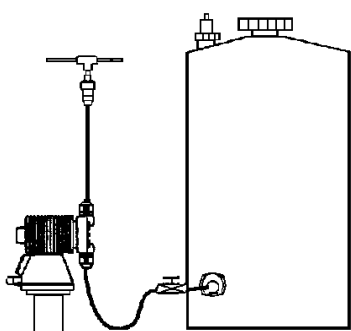

Figure 1
Flooded Suction

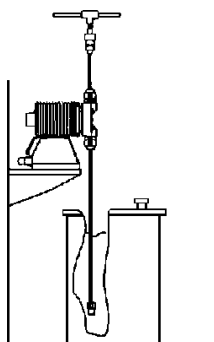

Figure 2
Shelf Mount

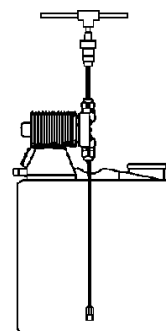

Figure 3
Tank Mount

bubbles. Sodium hypochlorite and hydrogen peroxide are common examples of such liquids. (See Figure 1.)

If flooded suction mounting is not possible, a shelf adjacent to (but not directly above) the supply tank often works well. (See Figure 2.) The supply tank or cover can also be used if it has provisions for mounting a pump. (See Figure 3.) In any case, the total suction lift should not exceed 1.5m.

3. Supply tubing

The supply tubing run should be as short as possible. For flooded suction mounting, install a shut-off valve with an appropriate tubing connector at the tank outlet. Cut a length of tubing and install between the shut-off valve and the pump inlet fitting. For suction lift applications, install a foot valve on one end of suction tubing and cut the tubing to a length such that the foot valve hangs vertically about 25mm above the bottom of the tank. Avoid any loops in the tubing run that could form a vapor trap. Running the tubing through a length of rigid pipe will help to keep tubing straight.

CAUTION

Suction tube length must be less than 1m. If it goes more than 1m, the discharge capacity drops.

4. Discharge tubing

The discharge tubing run is less critical and can be any length required to reach the application point. Avoid sharp bends or kinks in the tubing and protect the tubing from sharp edges that could chafe or cut it. If applicable, install the injection valve at the injection point and connect the tubing to the injection valve.

5. Electrical

Connect the pump power cord to a **GROUND**ED outlet supplying proper voltage. Avoid branch circuits that also supply power to heavy machinery or other equipment that could generate electrical interference.

3. OPERATION

1. Priming	-----	19
2. Adjustment	-----	20
3. Calibration	-----	20
4. External Control		
4,1 Display/Keypad and Wiring Overview	-----	21
4,2 Quick Reference	-----	22
4,3 Digital Mode	-----	23
4,4 Analog Mode / STOP Function	-----	24
4,5 AC Power Interruption	-----	26

1. Priming



Caution.

- Do not operate the pump with discharge-side valve completely closed.
Operating the pump with discharge-side valve fully closed may lead to liquid leakage or pipe rupture.
- Do not run pump dry.
Dry operation of the pump over a long time (longer than 30 minutes) causes the pump to overheat and the pump unit (pump head, valve guide etc.) to become deformed or the pump head attachment to become loose, which may result in liquid leakage trouble.
- Keep the pump head firmly assembled.
If mounting bolts on the pump head are loosened, liquid leakage may result.
 - * Fasten the 4 hex. socket bolts tightly before starting the initial pump operation. (The bolts may be loosened during storage or transportation of the pump, depending upon the condition.)
 - * Fastening torque: 2.16 N•m.
Tighten all the bolts fully by applying an equal amount of torque in a diagonal order among the bolts.

When the pump turned on but not pumping ,set stroke length at 100% and frequency at 360 spm(use the ▲ or ▼ buttons as necessary to adjust the frequency) . Disconnect the discharge tubing from the injection valve and push the **START/STOP** button to start the pump . When liquid enters the discharge tubing at the pump head, push the **START/STOP** button again to stop the pump and reconnect the discharge tubing to the injection valve .

2. Adjustment

The pump will operate best with the stroke length at 100%. It is recommended to get required flow rate by adjusting frequency control.

Example: Model EH-E30VC h as maximum output of 340ml/min.

Required output is 255 ml/min.

$255 \div 340 = 0.75$ or 75 %. 75 % of 360spm is 270spm.

Press the▲or▼ buttons as necessary to set the frequency to 270.

If very low outputs are required, it will be necessary to also reduce the stroke length. (Minimum recommended stroke length is 20%.)

3. Calibration

If exact output calibration is required, first prime and adjust the pump as above. Then connect a calibration column to the suction side of the pump. Turn the pump on for one minute and read the amount of liquid pumped from the column. Adjust the frequency up or down as necessary and check the output again. When the desired output is reached, disconnect the calibration column and reconnect the suction tubing. (See Figure 4.)

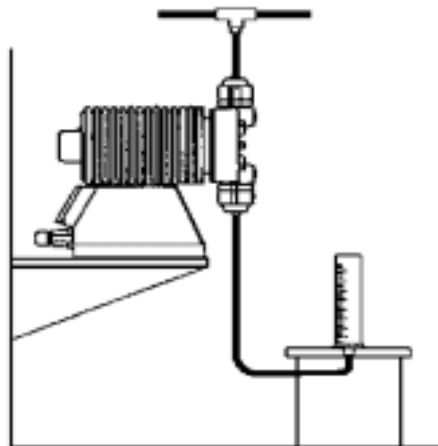

Figure 4
Calibration

4. External Control 4. 1 Display/Keypad and Wiring Overview

Start/Stop Key.

Manually starts or stops the pump. This key is used in setting external modes.

EXT key.

Push to set pump for external input operation.

WAI T indicator.

Visible when pump is in standby mode.

EXT indicator .

Visible when pump is operating via external input.

STOP indicator.

Visible when the pump is stopped via external signal. The pump stops pumping.

Alpha numeric display.

Indicates stroke frequency, or external mode or external settings.

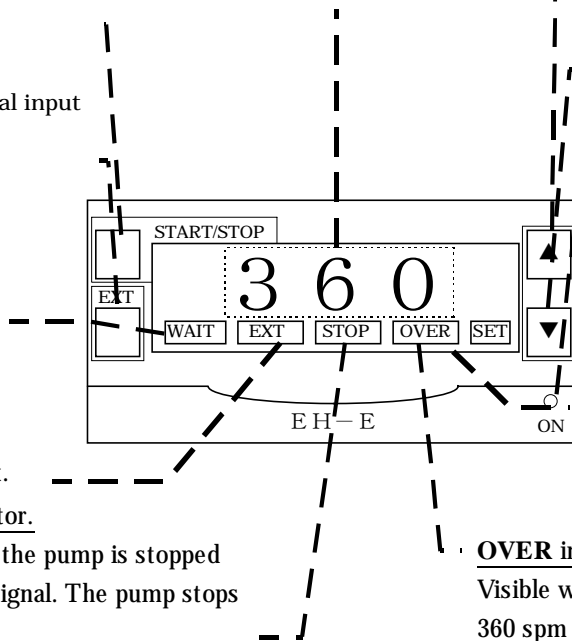

UP key.

Increases numeric values. Is used with EXT key to select external modes.

DOWN key .

Decreases numeric values. Is used with EXT key to select external settingmode.

ON light.

Indicates AC power to the pump and goes on and off with each stroke.

SET indicator.

Visible when pump external mode and/or settings are being selected.

OVER indicator.

Visible when an input signal exceeds the 360 spm capability.

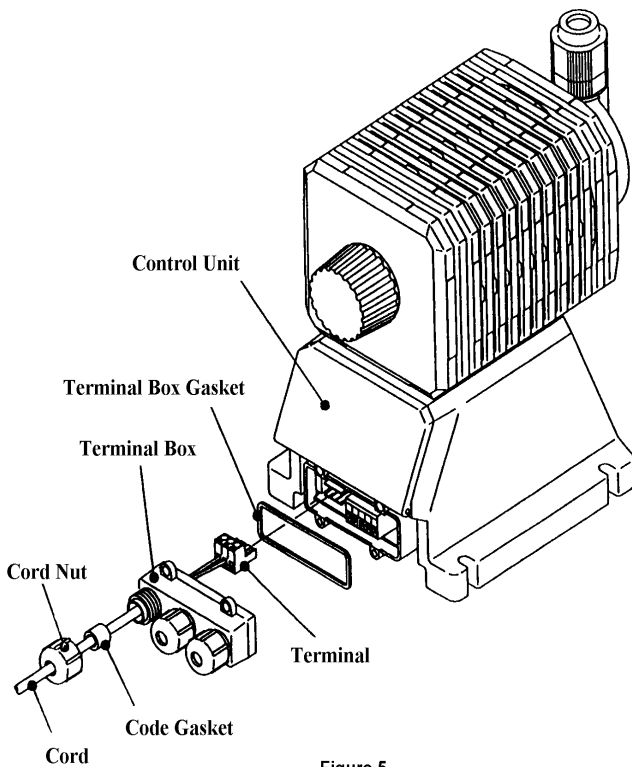
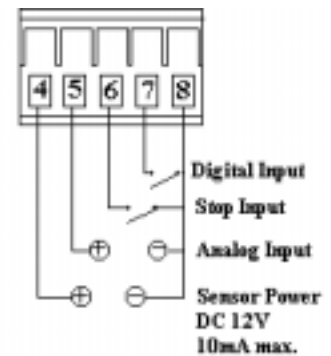
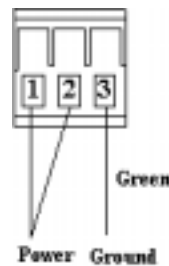

Figure 5



4. External Control 4. 2 Quick Reference

EHE Quick reference Guide S/S =Start/Stop key EXT =EXT[ternal]key

From:	Press	To	
WAIT	S/S	run in manual mode	
	▼	decrease frequency (360 to 1 spm)	
	▲	increase frequency (1 to 360 spm)	
	EXT	run EXT	
	EXT + ▲	SET external mode	
	EXT + ▼	SET external values	
Run manual	▼	decrease frequency (360 to 1 spm)	
	▲	increase frequency (1 to 360 spm)	
	S/S	return to WAIT	
Run EXT	S/S	return to WAIT	
SET external mode	▲	select DIG (multiply or divide)	
	▼	select ANA (milliamp input)	
	S/S	accept data and return to WAIT	
SET external values	EXT	select / (divide) or X (multiply)	
	▲	increase value (1 to 999)	
	▼	decrease value (999 to 1)	
	S/S	accept data and return to WAIT	
	ANA	▲ or ▼	select 4-20,20-0,20-4 , or 0-20
		S/S	accept data and return to WAIT

4. External Control 4. 2 Quick Reference

Mode Change and Operation of Keys

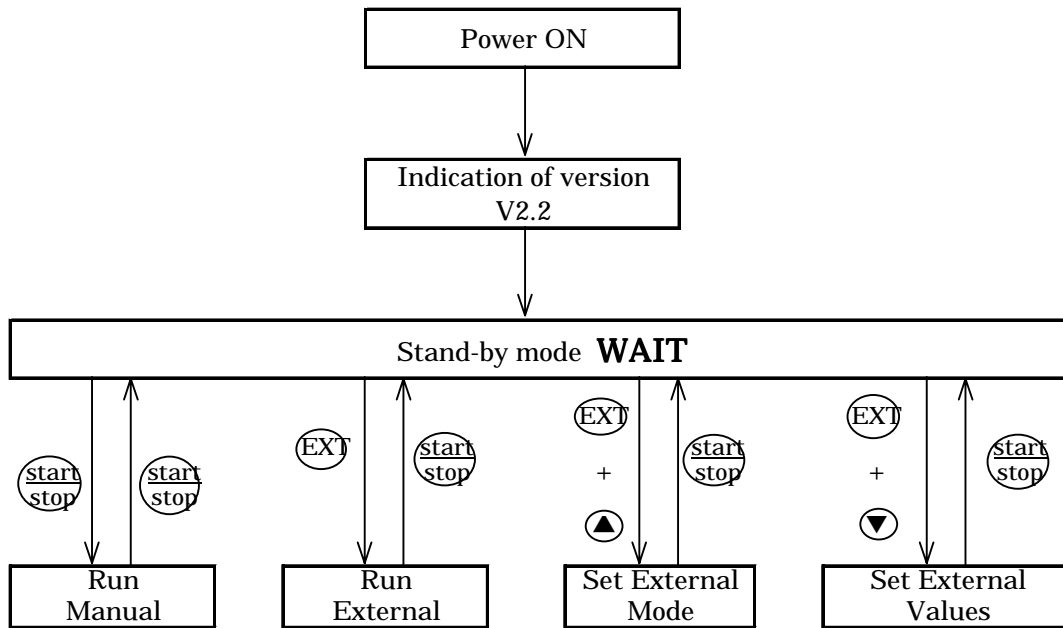

Signal Operation Mode

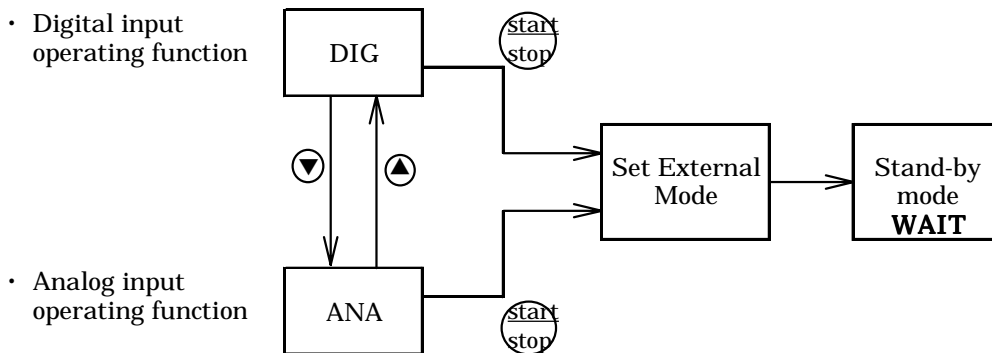

4. External Control 4. 2 Quick Reference

Signal Setting Mode : Digital Input Operating Function

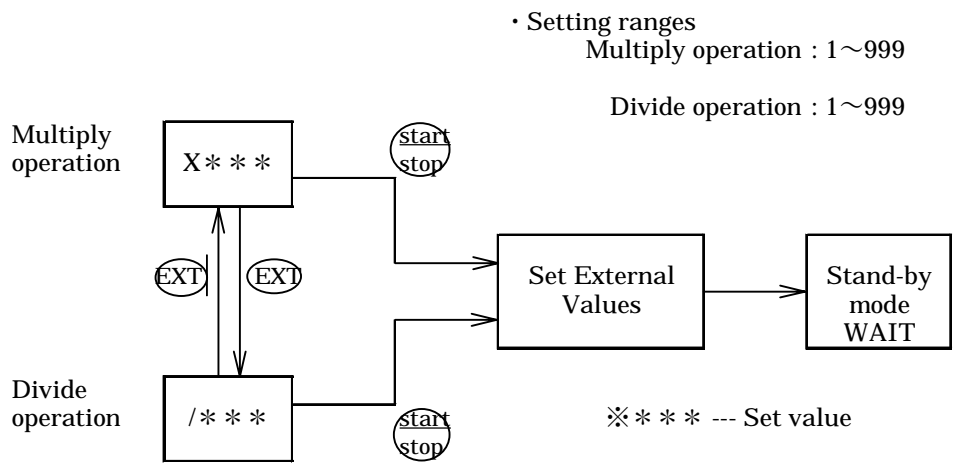

Signal Setting Mode : Analog Input Operating Function

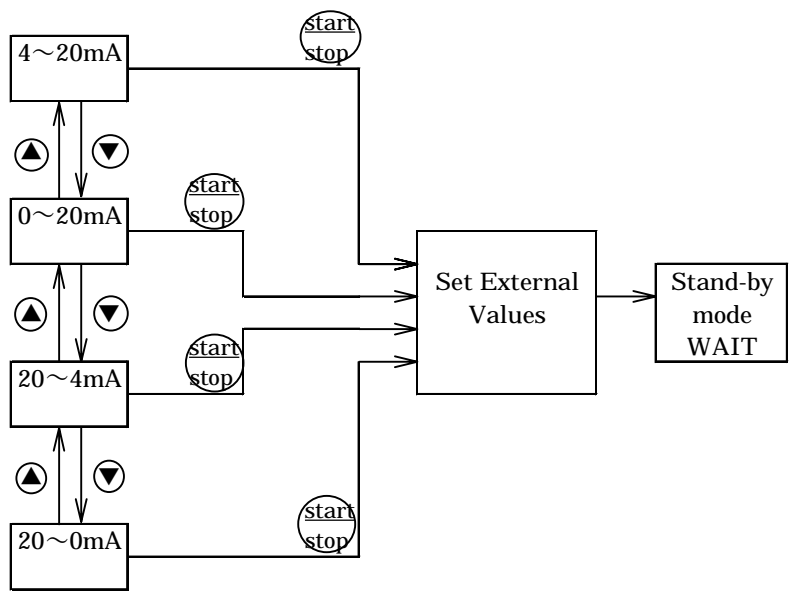

4. External Control 4.3 Digital Mode

4-2. Set multiply or divide

To set values for digital operation, press **EXT** and **▼** simultaneously. The display will show / or X and a 3 digit number. Now pressing the **EXT** button will alternate between X (multiply) and / (divide).

4-3. Set the value

▲ or **▼** will increase or decrease the multiplier or divider. Pressing a button once will change the value by one. Holding a button down will continuously increment or decrement the value, slowly at first, then rapidly. Press **START/STOP** to accept values and return to **WAIT**.

Press **EXT** to operate the pump in external mode. The pump will now respond to the incoming pulse signal. The stroke length can be adjusted manually to set the volume pumped per stroke.

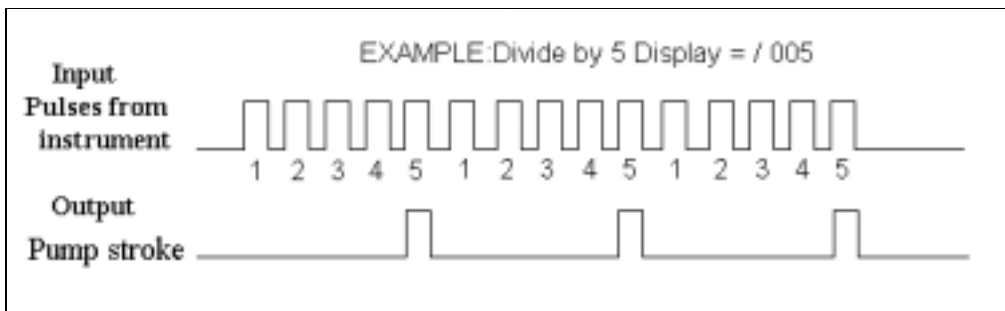
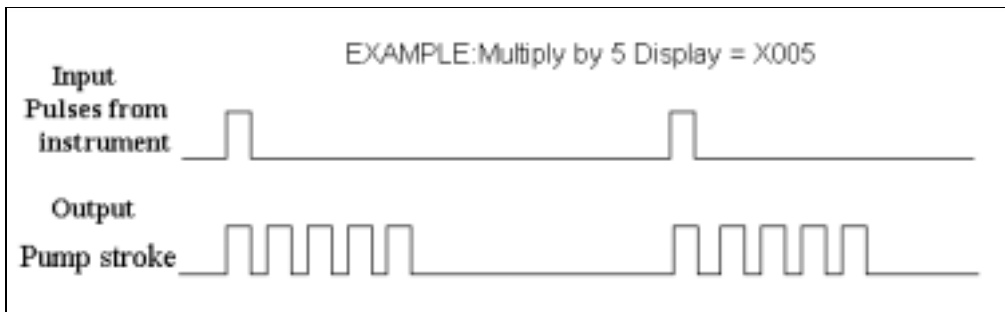

4. External Control 4.4 Analog Mode

4.4 Analog Mode. In analog mode the pump will accept a milliamp signal and produce a pump speed proportional to the signal level received. Signal ranges of 4-20, 0-20, 20-4 or 20-0 can be selected.

1. Connecting an analog signal device

Disconnect AC power to the pump. Gently spread the latches at the sides of the terminal block cover and remove the cover. Remove the cord nut and bushing from the terminal block cover. Remove the terminal block from the connector. Slide the nut and bushing over the external control cable and insert the cable through the terminal block cover. Strip 6mm' insulation from conductors and connect the positive side to terminal 5 and the negative side to terminal 8.

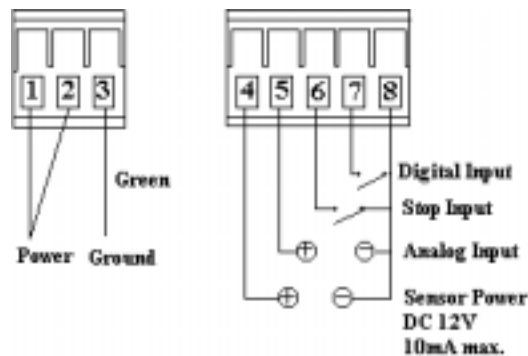

2. Settings

Start with pump in the **WAIT** state. If it is not currently in wait, press **START/STOP** once.

3-1. Set it to analog mode

Press **▲** and **EXT** simultaneously. The **SET** indicator is highlighted and **DIG** (digital) or **ANA** (analog) will be displayed. If **ANA** is displayed, press **START/STOP** to accept that mode. You will be returned to the **WAIT** state. If **DIG** is displayed, press the **▼** button to change to **ANA** and then press **START/STOP** to enter that choice. You will be returned to the **WAIT** state.

3-2. Set the value

To set values for analog operation press **EXT** and **▼** simultaneously. The display will show 4-20, 20-0, 20-4 or 0-20. Press **▲** or **▼** to change the selection to the desired signal range and response. Press **START/STOP** to accept the value and return to **WAIT**.

4. External Control 4. 4 Analog Mode

Press EXT to operate the pump in external mode. The pump speed will now be determined by the level of the milliamp signal as shown in the graph. The stroke length can be adjusted manually to set the volume pumped per stroke.

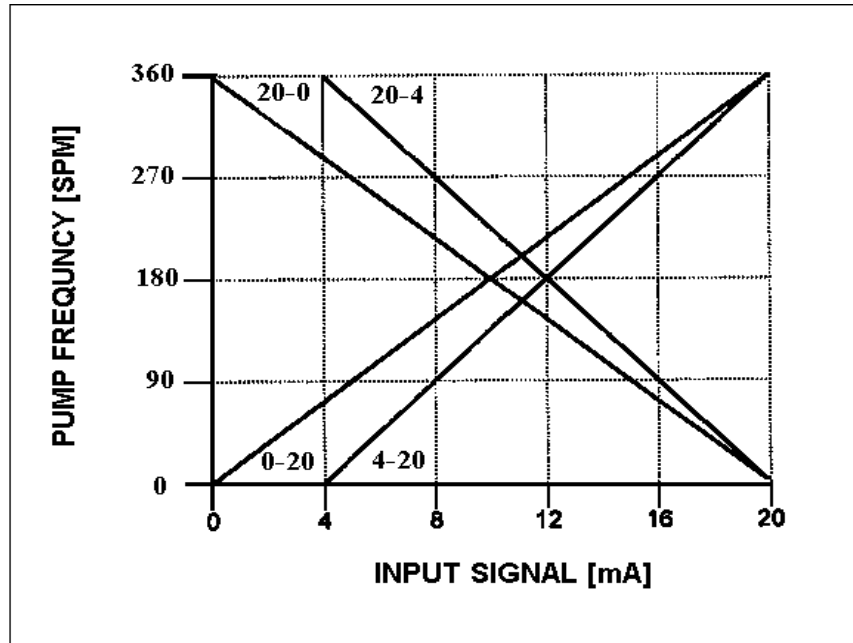

4.STOP Function

The EH-E series pump also includes a STOP function which allows an external signal to stop the operation of the pump. A switch or solid state device capable of switching 5 VDC at 2 mA can be connected to terminals 6 (positive) and 8 (negative) of the terminal block. Closing this circuit temporarily interrupts pump operation. Opening this circuit resumes pump operation. If the pump is operating in external digital mode, any pulses received while the pump is stopped will be saved (up to a maximum of 255). When pump operation resumes, saved pulses will allow the pump to "catch up" by producing the correct number of pump strokes that should have occurred while it was stopped.

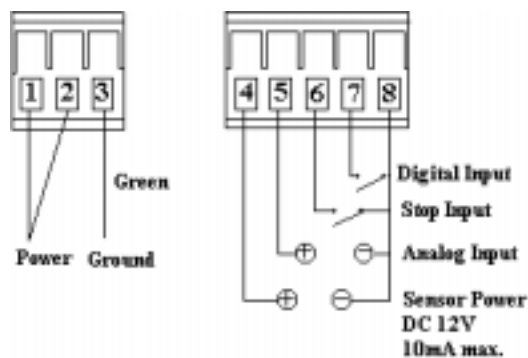

4. External Control 4. 5 AC Power I ntteruption

If AC power is interrupted and then returned, the functions return as shown below.

State before power is interrupted	State after power returned
WAIT	WAIT
Run manual	Run manual
Run external	Run external
Set EXTernal mode	WAIT
Set EXTernal values	WAIT

4.Maintenance

1.	<i>Maintenance</i>	-----	30
2.	<i>Diaphragm Replacement</i>	-----	30
3.	<i>Valve Replacement</i>	-----	30
4.	<i>Tubing</i>	-----	30
5.	<i>Names of Part and Structure</i>	-----	31

1. Maintenance

Caution



Before working on the pump, disconnect the power cord, depressurize the discharge tubing and drain or flush any residual liquid from the pump head and valves.

2. Diaphragm Replacement

Disconnect AC power to the pump and disconnect the suction tubing and discharge tubing. Remove the four head bolts with a 4mm hex wrench. Turn the stroke length knob fully counter-clockwise. Unscrew the diaphragm and remove its retainer (small disk behind the diaphragm). Install the new retainer and diaphragm on the shaft. Turn the diaphragm clockwise until it bottoms on the shaft. Replace the pump head and tighten the head bolts to a torque of 2.6 N.m.

3. Valve Replacement

Remove the suction and discharge tubing. Remove the suction fitting, two valve cartridges, o-ring and gasket(s). Install the new o-ring, gasket(s) and valve cartridges. Be sure both valve seats are in the same orientation. Refer to Figure 6, below. Tighten the suction fitting. Similarly remove and replace the discharge valve cartridges, o-ring and gasket(s).

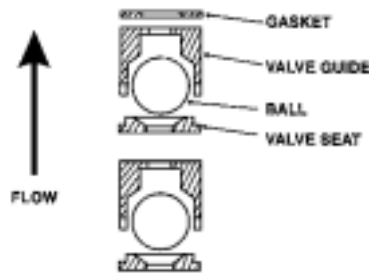

Figure 6
Valve Cartridge Orientation

4. Tubing

Check ends of tubing for splits, cracks, or thin spots. Examine the full length of tubing for damage due to chafing, abrasion, stress cracks, excessive temperature or exposure to ultraviolet light (direct sunlight or mercury vapor lamps). If any signs of deterioration exist, replace the entire length of tubing. It is a good idea to replace discharge tubing on a regular preventive maintenance schedule every 12 months.

5. Names of Part and Structure

(1) Pump Head Unit (Material symbol: VC/V6/PC/P6/VM/FC)

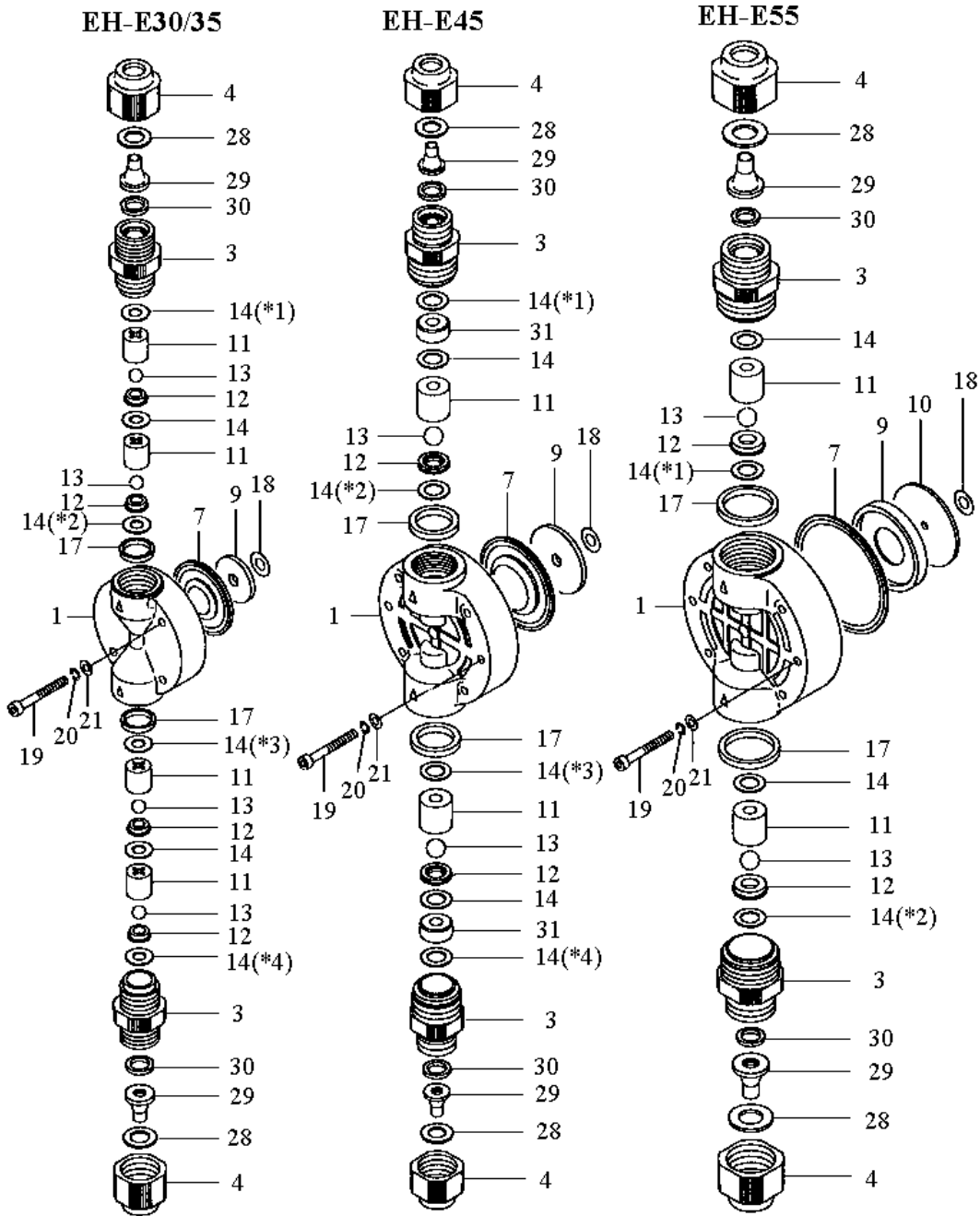

*1-4: for type FC only

5. Names of Part and Structure

(2) Pump Head Unit (Material symbol: SH)

E30/E35/E45

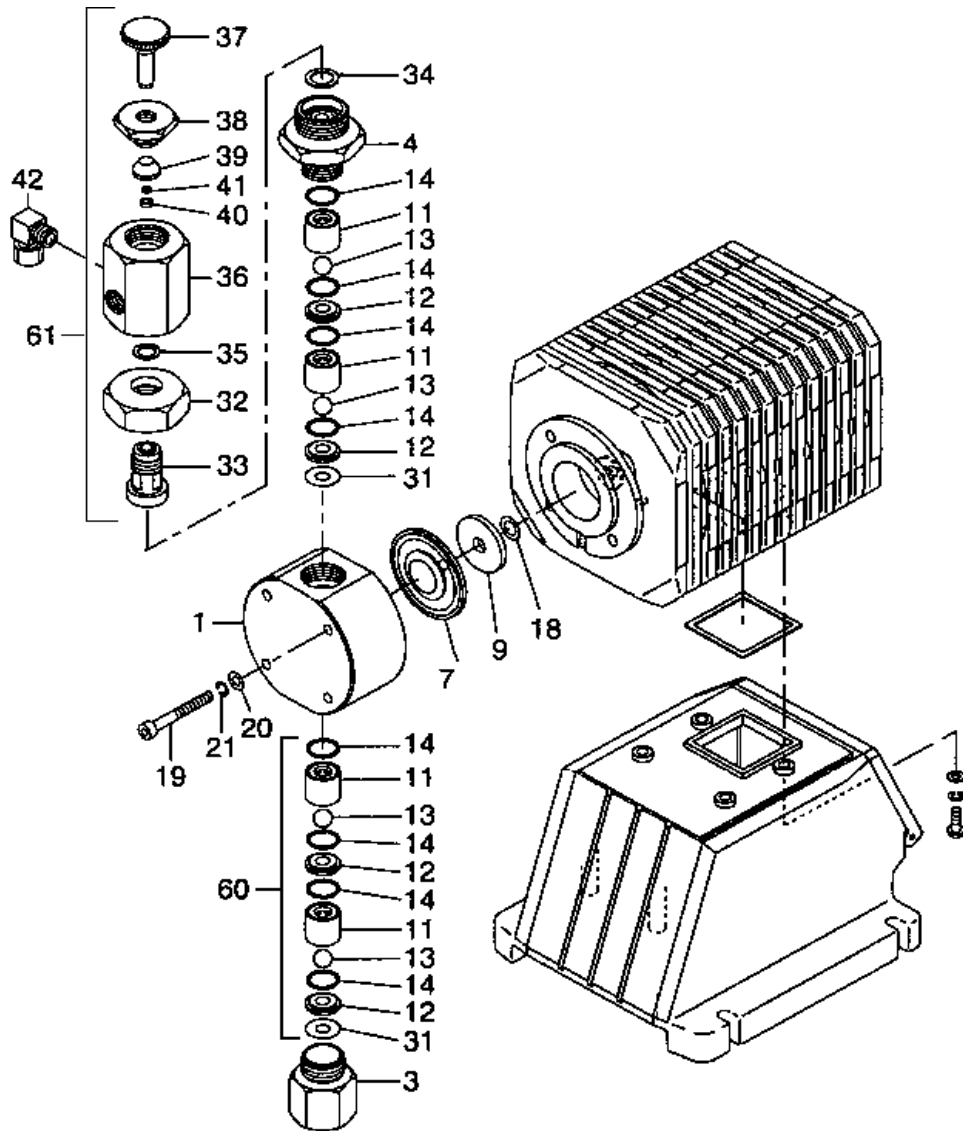

5. Names of Part and Structure

(3) Pump Head Unit (Material symbol: SH)

E55

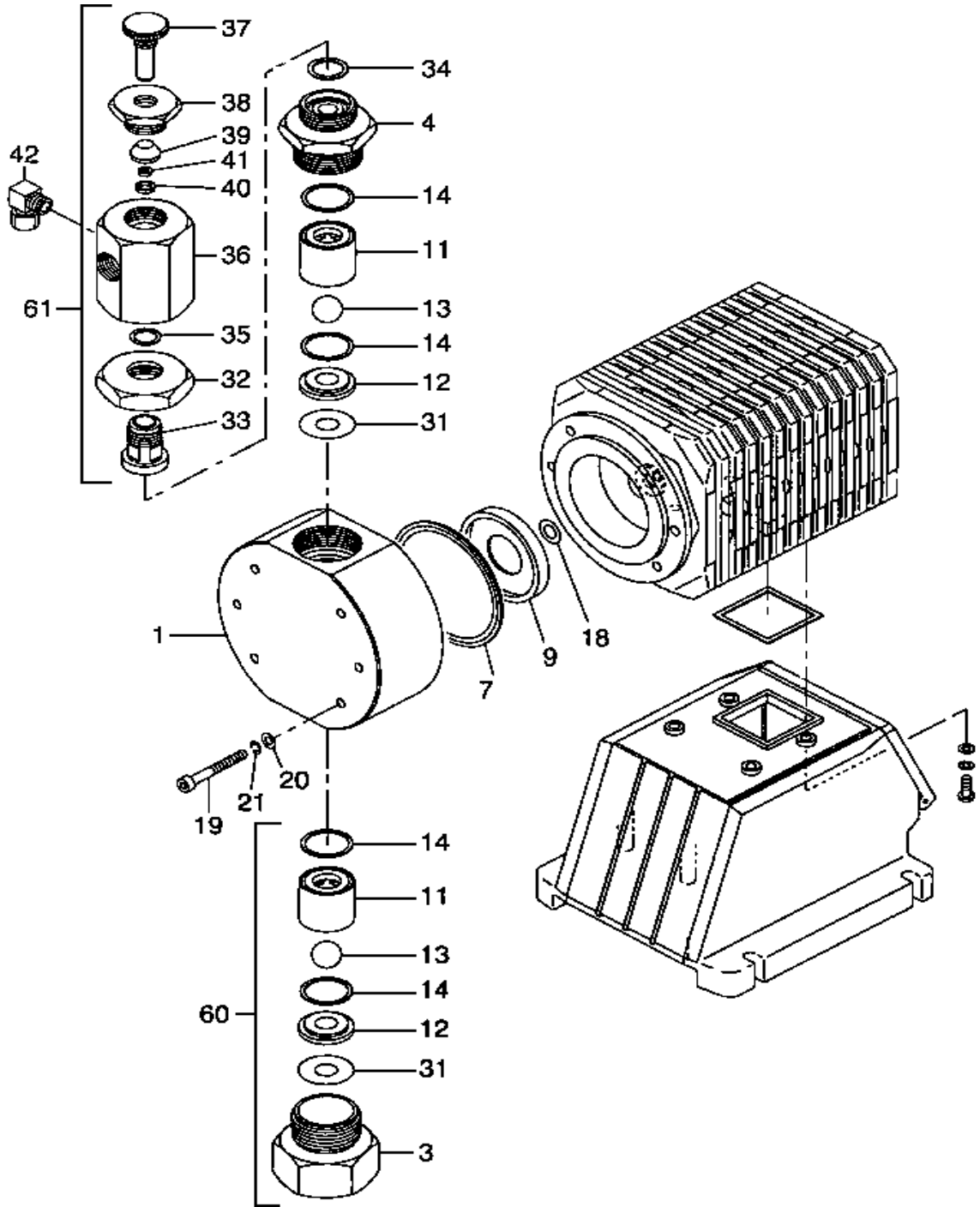

Parts name of pump head

No.	Parts name for types VC/V6/PC/VM/FC	No.	Parts name for type SH
1	Pump head	1	Pump head
3	Fitting	3	Suction fitting
4	Fitting nut	4	Discharge fitting
7	Diaphragm	7	Diaphragm
9	Retainer	9	Retainer
10	Back up retainer	11	Valve guide
11	Valve guide	12	Valve seat
12	Valve seat	13	Valve ball
13	Valve ball	14	Valve gasket
14	Valve gasket	18	Diaphragm spacer
17	O-ring (Gasket for type FC)	19	Hex. sock. cap bolt
18	Diaphragm spacer	20	Plain washer
19	Hex. sock. cap bolt	21	Spring washer
20	Plain washer	31	Gasket
21	Spring washer	32	Nut
28	Hose stopper	33	Fitting
29	Fitting spacer	34	Fitting gasket
30	O-ring (Gasket for type FC)	35	Air vent gasket
		36	Air vent body
		37	Adjusting screw
		38	Seal nut
		39	Seal ring
		40	Seat
		41	Seat ring
		42	Tube connector

5. Troubleshooting

1. <i>Troubleshooting</i>	-----36
---------------------------	---------

1. Troubleshooting

Caution



Before working on the pump, disconnect the power cord, depressurize the discharge tubing and drain or flush any residual liquid from the pump head and valves.

<u>Problem</u>	<u>Possible Cause</u>	<u>Corrective Action</u>
Pump does not start	Faulty wiring	Correct wiring
	Improper voltage	Connect to proper voltage source
	Electronic control unit is damaged	Replace control unit
Pump does not prime	Pump stroke length is too short	Operate pump with stroke length set at 100% until primed. Then set stroke length as needed to obtain desired output.
	Air in suction tubing	Reroute suction tubing to eliminate air trap
	Valve gasket is missing	Install valve gasket
	Valve set assembly direction is wrong.	Reassemble valve set
	Pump is air locked	Prime pump per instructions
	Suction or discharge valve is clogged with foreign matter	Disassemble, inspect, clean
	Ball stuck to valve seat	Disassemble, inspect, clean
Output fluctuates	Suction or discharge valve is clogged with foreign matter	Disassemble, inspect, clean
	Air is trapped in pump	Prime pump per instructions
	Overfeeding	Install injection valve or back pressure valve
	Diaphragm is damaged	Replace diaphragm
	Worn check valves	Replace valve cartridges
Liquid leaks	Fitting or coupling nut is loose	Tighten
	Pump head is loose	Tighten pump head bolts Torque: 2.6 N.m
	Diaphragm is damaged	Replace diaphragm
	O-ring or valve gasket missing	Install o-ring or valve gasket

IWAKI PUMPS



IWAKI CO., LTD

6-6 Kanada-sudacho, 2-chome, Chiyoda-ku

Tokyo 101-8558 Japan

Tel: (81) 3 3254 2935 Fax: (81) 3 3252 8892

T308-1 99/2