

IWAKI

Magnetic Drive Pumps
Product Guide



An Overview of Iwaki's World Leading Magnetic Drive Pumps

Magnetic drive technology is fast becoming the pump choice for corrosive applications.

Iwaki offers a wide range of magnetic drive pumps from fractional horsepower

for OEM applications to large pumps for chemical processing.

No other manufacturer can offer such a wide breadth of technology.

This brochure is an overview of Iwaki's large chemical process pumps.

For information on our smaller pump technology please contact Iwaki or visit www.iwakipumps.jp



CONTENTS

Fluoroplastic (ETFE/CFRETFE/PFA)

Magnetic Drive Pumps (MDM, MXM, SMX-F, MX-F)-----	page 3
Large Magnetic Drive Pumps (MDW, MDE) -----	page 5
Performance Comparison-----	page 7
Materials-----	page 8

Liquid end materials: ETFE/CFRETFE/PFA

page
9

MDW series



Liquid end materials: ETFE/CFRETFE/PFA

page
11

MDE series



Liquid end materials: CFRETFE/PFA

page
13

MDM series



Liquid end material: CFRETFE

page
15

MXM series



Liquid end material: CFRETFE

page
17

SMX-F series



Liquid end material: CFRETFE

page
19

MX-F series



Polypropylene (CFRPP/GFRPP)

Performance Comparison-----	page 23
Materials-----	page 24

Liquid end material: CFRPP

page
25

AMP series



Liquid end material: GFRPP

page
27

SMX series



Liquid end material: GFRPP

page
29

MX series



Installation Precautions-----	page 32
Magnetic Drive Pumps use-----	page 33
Optional Accessories-----	page 34

Magnetic Drive Pumps

(MDM, MXM, SMX-F, MX-F)

Unique design prevents dry running Non contact system (PAT. PEND.)

High powered rare earth magnets prevent the magnet capsule from coming in contact with the rear casing, thus preventing heat generation. This improves the dry running resistance and increases pump life in comparison to other fluororesin pumps.

MDM



MDM

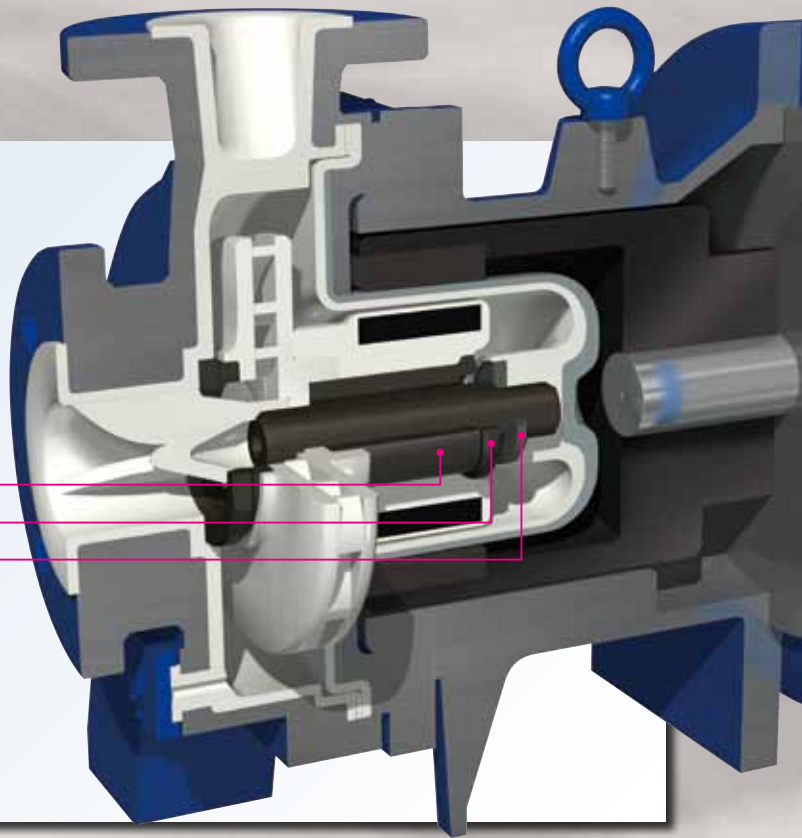

Bearing
Rear ring
Rear thrust

ETFE and PFA available in standard models

Carbon fiber reinforced CFRETFE and PFA liners are available for varying applications. The unfilled PFA liners are ideal for high purity chemical applications.

MDM

Modular design and low maintenance cost

The pumps modular design leads to easy maintenance. There is no need to check clearances or align any liquid end parts. All wetted parts can be replaced individually reducing maintenance costs.

MDM



MXM



Highly durable structure

The ductile cast iron body of the pump provides strength and durability. The rear casing utilizes a secondary pressure containment cover made of fiber reinforced plastic. This allows for higher pressures as well as temperatures without the efficiency loss of eddy current generation. Should the drive magnet come in contact with the rear casing cover its non-metallic design will not generate sparks.

MDM | MXM

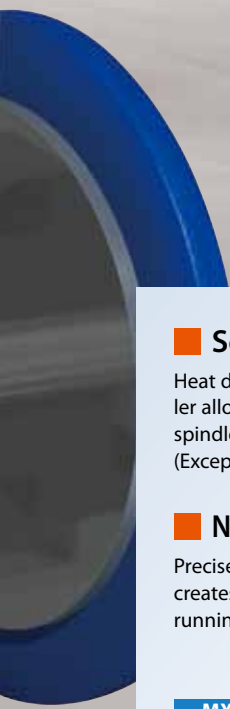

Self-radiating structure (PAT.)

Heat dispersion holes in the magnet capsule and impeller allow liquid circulation that cools the radial bearing and spindle. This design prevents melting due to excessive friction. (Except MX-F100)

Non-contact structure

Precise alignment of the drive magnet and magnet capsule creates a non-contact system that prevents friction during dry running.

MXM

SMX-F

MX-F



SMX-F

Fast self-priming

The SMX-F requires no external self-priming chambers or valves. The gas-liquid separation design ensures fast self-priming of up to 4 meters in under 90 seconds.

SMX-F

Volute casing divided into two sections (PAT.)

The first non-metallic magnetic drive pump to incorporate a vortex chamber in the front and rear casings to increase pump efficiencies. (Except MX-F400)

MX-F



MX-F

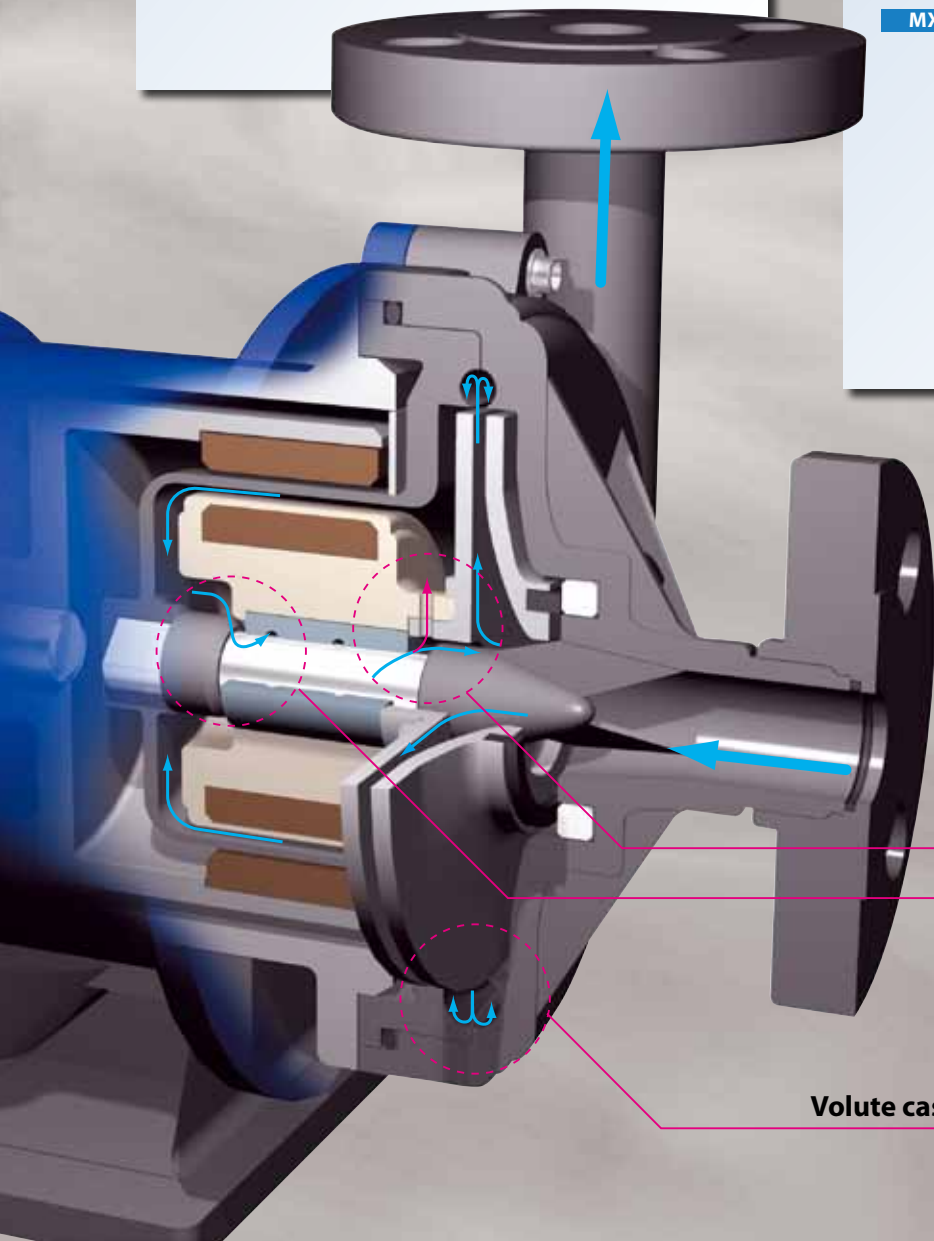

Self-radiating structure (PAT.)

Non-contact design

Volute casing divided into two sections (PAT.)

Large Magnetic Drive Pumps

(MDW, MDM)

The world's largest fluoroplastic magnetic drive pump

The MDW series are the largest fluoroplastic magnetic drive pumps in the world, offering high efficiency and durability for chemical process applications. Larger motors create higher outputs taking the MDW series into new high flow applications.

MDW



Back pullout system

The back pullout system allows easy maintenance and inspection without removing the pump from the piping. Integrated components and a sealed rear casing support structure allow motor removal without chemical leakage.

MDW MDE

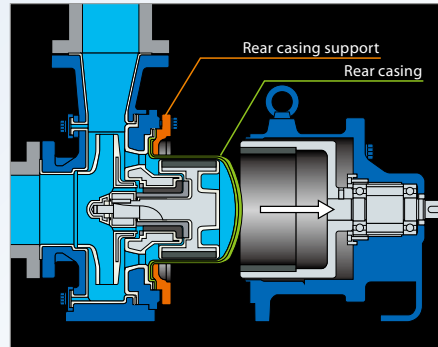

Compliant with ISO

The performance and dimensions standards of the pumps are in compliance with the international standard (ISO2858, 3661, 5199). They are interchangeable with general-purpose centrifugal pumps.

*MDW is ISO2858, 3661 only
• Model MDE 125-250 is excluded

MDW MDE

Robust structure

The ductile cast iron body of the pump provides strength and durability. The rear casing utilizes a patented triple layer structure for high pressure resistance. A metal shaft is incorporated in the MDW & MDE design to withstand high radial forces and allow continuous operation even under difficult service conditions.

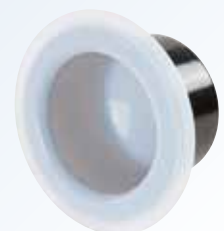

MDW MDE



Liquid end
materials

ETFE
CFRETFE
PFA

Performance Comparison for Iwaki Magnetic Drive Pumps

Materials: Fluoroplastic (ETFE/CFRETFE/PFA)

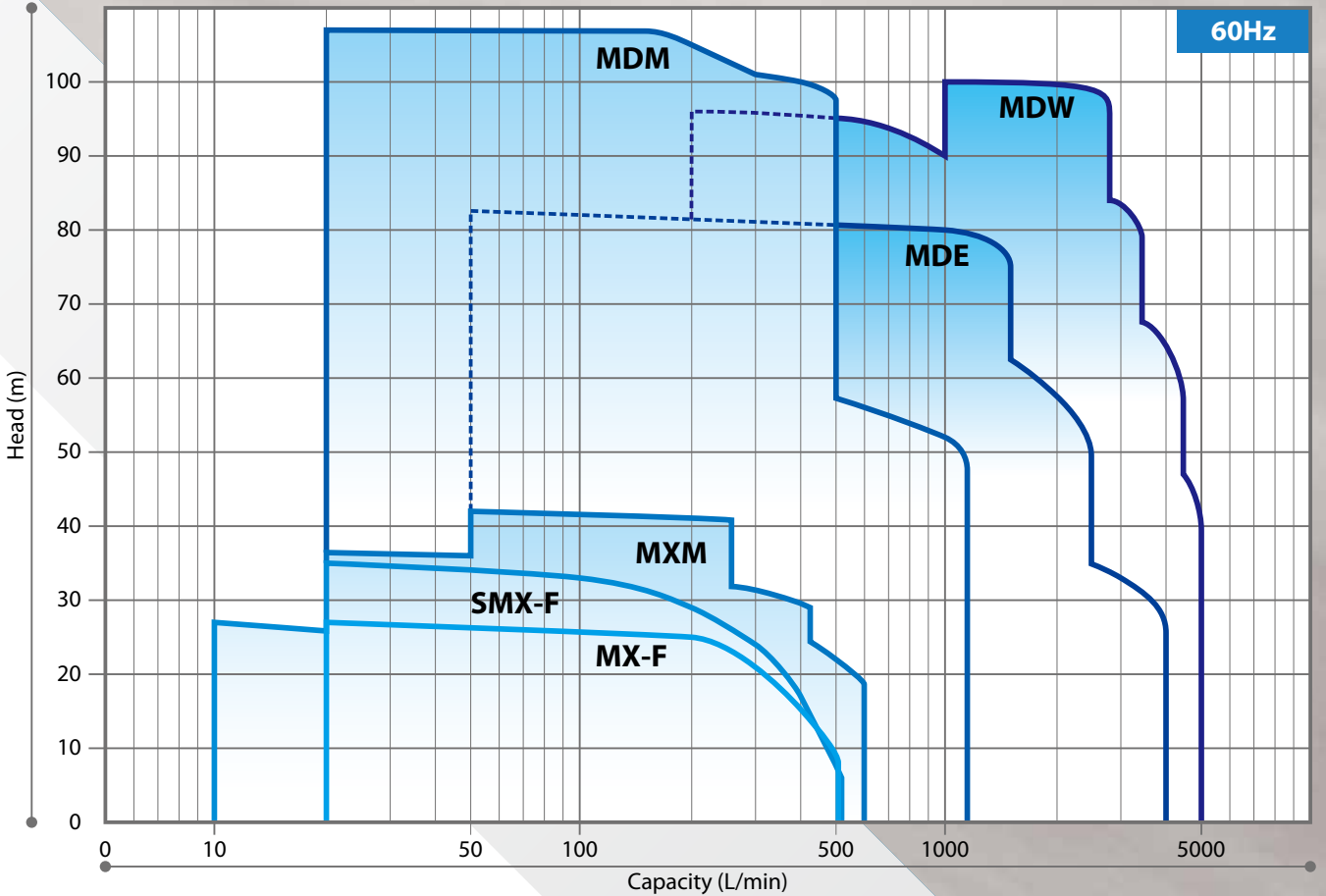
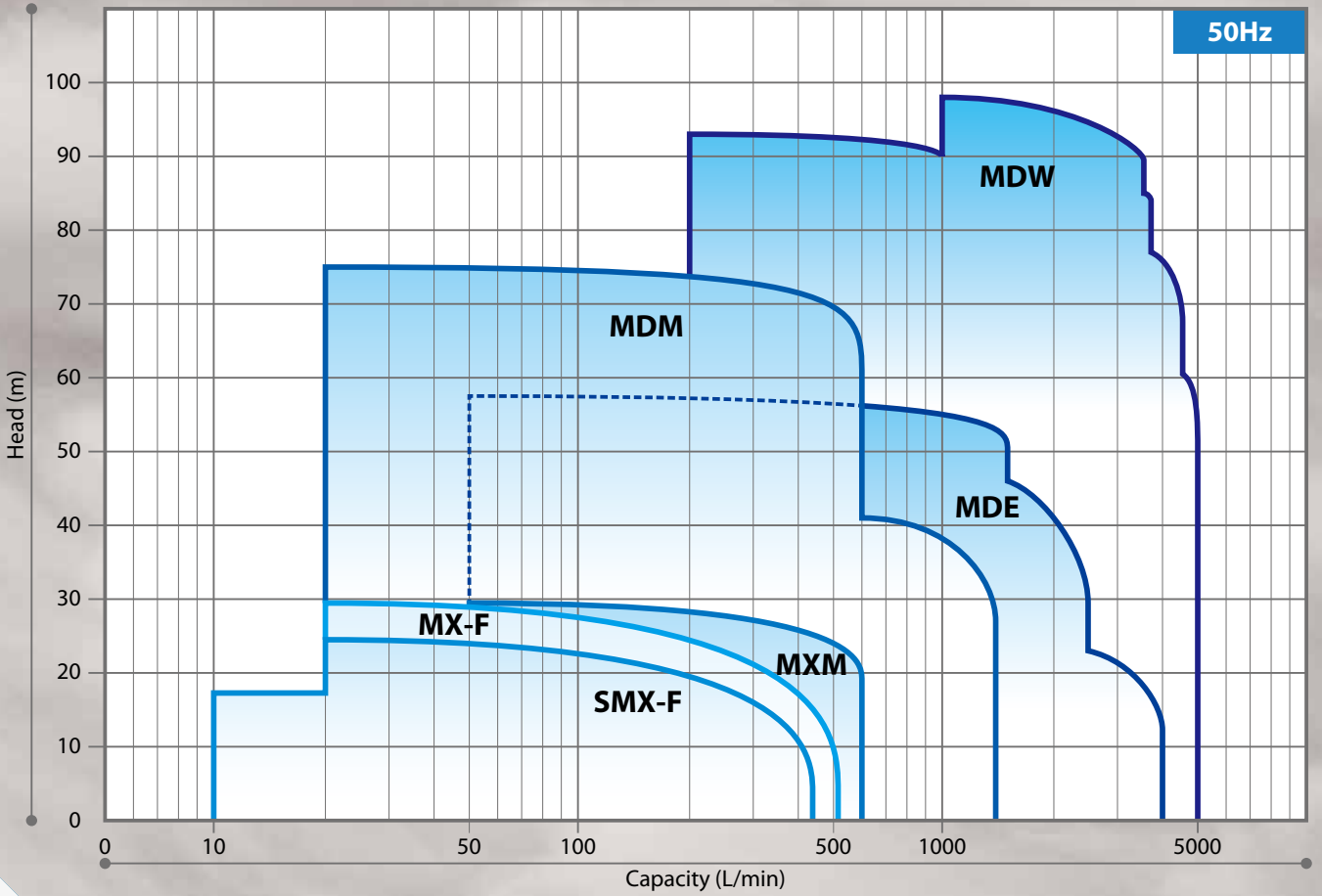

Liquid end Materials

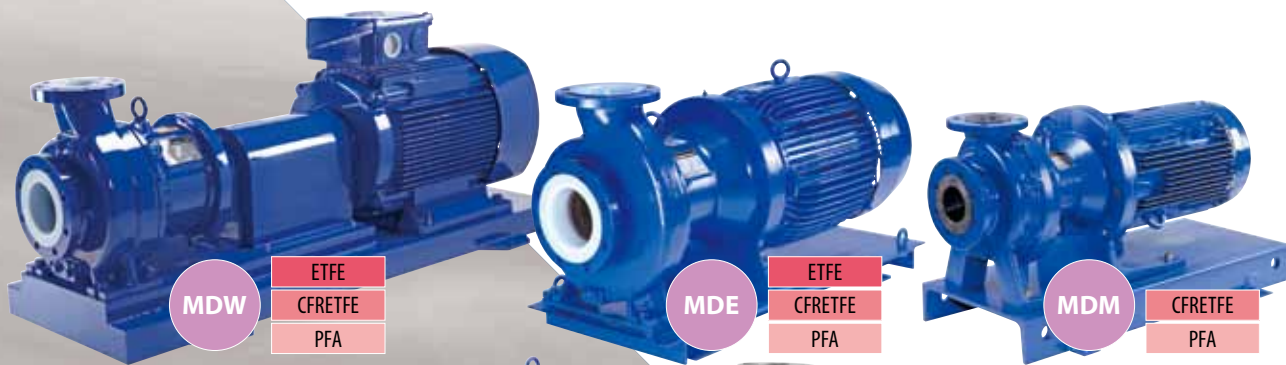

Fluoroplastic
(ETFE/CFRETFE/PFA)



Materials

Model	Molded				Bearing system		Static sealing parts	
	Front casing	Rear casing	Impeller	Magnet capsule	Bearing	Spindle	Gasket	O ring
MDW	ETFE	PFA	CFRETFE	PFA	SiC	SiC	PTFE	Kalrez®
	PFA		PFA					
MDE	ETFE	PFA	CFRETFE	PFA	SiC	SiC	PTFE	Kalrez®
	CFRETFE		FKM					
								EPDM
MDM	CFRETFE	CFRETFE	CFRETFE	CFRETFE	High density carbon	High purity alumina ceramic	PTFE	—
	PFA	PFA	PFA	PFA	SiC	SiC		
MXM	CFRETFE	CFRETFE	CFRETFE	CFRETFE	High density carbon	High purity alumina ceramic	AFLAS®	AFLAS®
					High purity alumina ceramic	SiC	DAI-EL PERFLUORO®	DAI-EL PERFLUORO®
					SiC		FKM	FKM
SMX-F	CFRETFE	CFRETFE	CFRETFE	CFRETFE	High density carbon	High purity alumina ceramic	FKM	FKM
					PTFE			
					SiC			
MX-F	CFRETFE	CFRETFE	CFRETFE	CFRETFE	High density carbon	High purity alumina ceramic	—	FKM
					PTFE			
					SiC			

Material index

Plastic materials	
PFA	Tetrafluoroethylene/perfluoroalkoxy vinyl ether copolymer
ETFE	Ethylentetrafluoroethylene copolymer ("Fluon", etc.)
CFRETFE	Carbon fiber-reinforced ETFE
PTFE	Polytetrafluoroethylene ("Teflon", etc.)

Rubber	
FKM	Fluorine rubber
EPDM	Ethylene propylene rubber

Materials for sliding parts/bearings	
High-density carbon	Hard carbon
Highly pure ceramic	Alumina ceramic with a purity of 99.5% or more
SiC	Silicon carbide ceramic

Performance curves

- Pump size (Suction×Discharge) MDW50: 80A×50A, MDW80: 125A×80A, MDW100: 125A×100A
- 2P: 2P poles motor, 4P: 4P poles motor

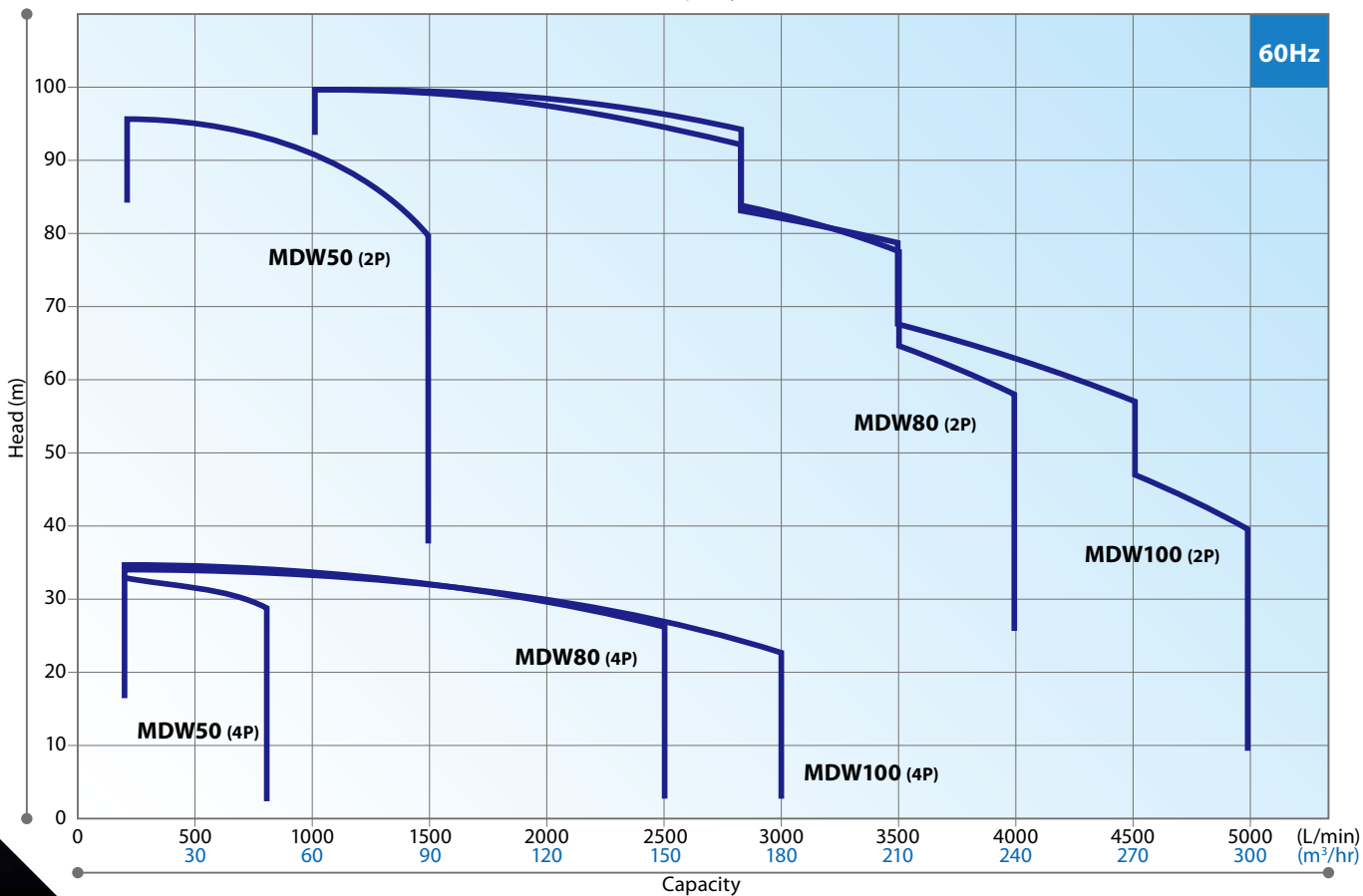
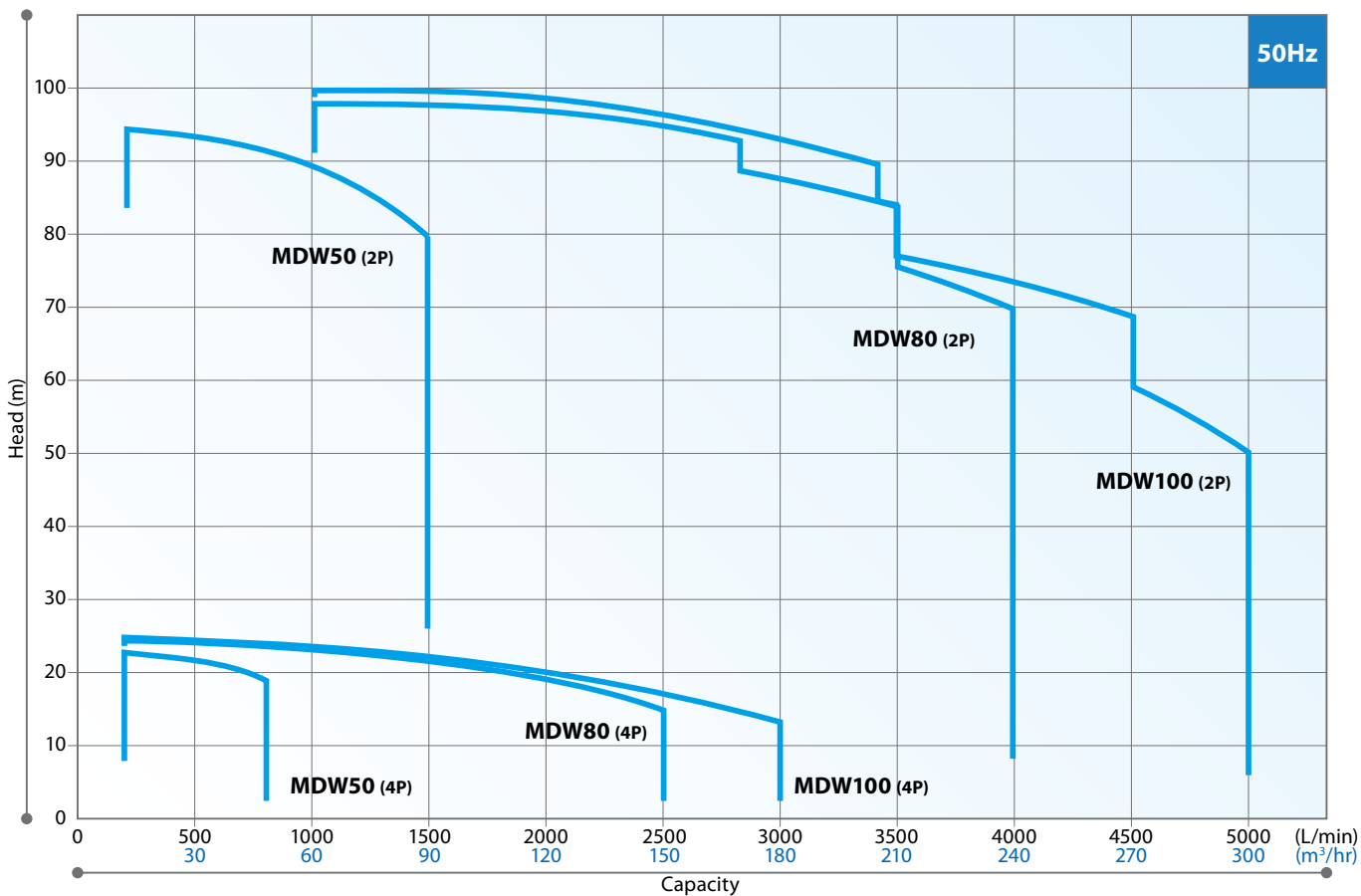

ETFE/CFRETFE/PFA
MDE



Liquid end materials
ETFE/CFRETFE/PFA

MDE series

- Strong corrosion resistance
- High durability
- Compliant with ISO standards
- Back pullout design

Specifications (50/60Hz)

Max. discharge capacity240 m³/hr
Max. discharge head55/82 m
MaterialsETFE, CFRETFE, PFA
Power range11 to 45_(60Hz) kW
Pump size (Discharge)65 to 125 A
Liquid temp. range0 to 100°C*

Specific-gravity limit3.0
(For details, please contact Iwaki.)
Sealing methodSeal-less construction

*Fluid dependent.

Liquid end materials

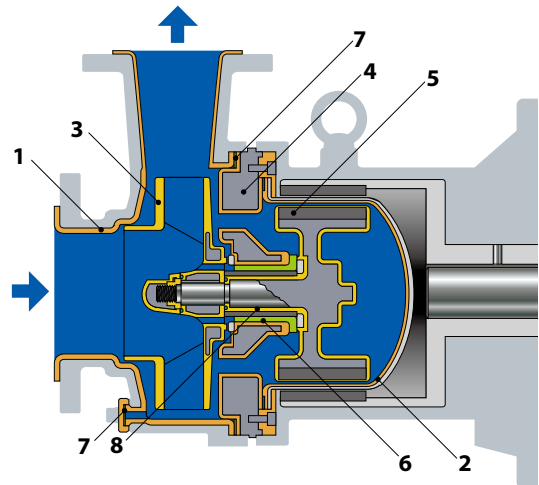

- 1 Front casing ETFE
- 2 Rear casing PFA
- 3 Impeller CFRETFE
- 4 Split plate PFA
- 5 Magnet capsule PFA
- 6 Bearing SiC
- 7 Gasket PTFE
- 8 O ring Kalrez®, FKM, EPDM

The world's largest
non-metallic magnetic drive pumps
for chemical processing

Performance curves

• Pump size (Suction×Discharge) MDE65: 80A×65A, MDE80: 100A×80A, MDE125: 150A×125A

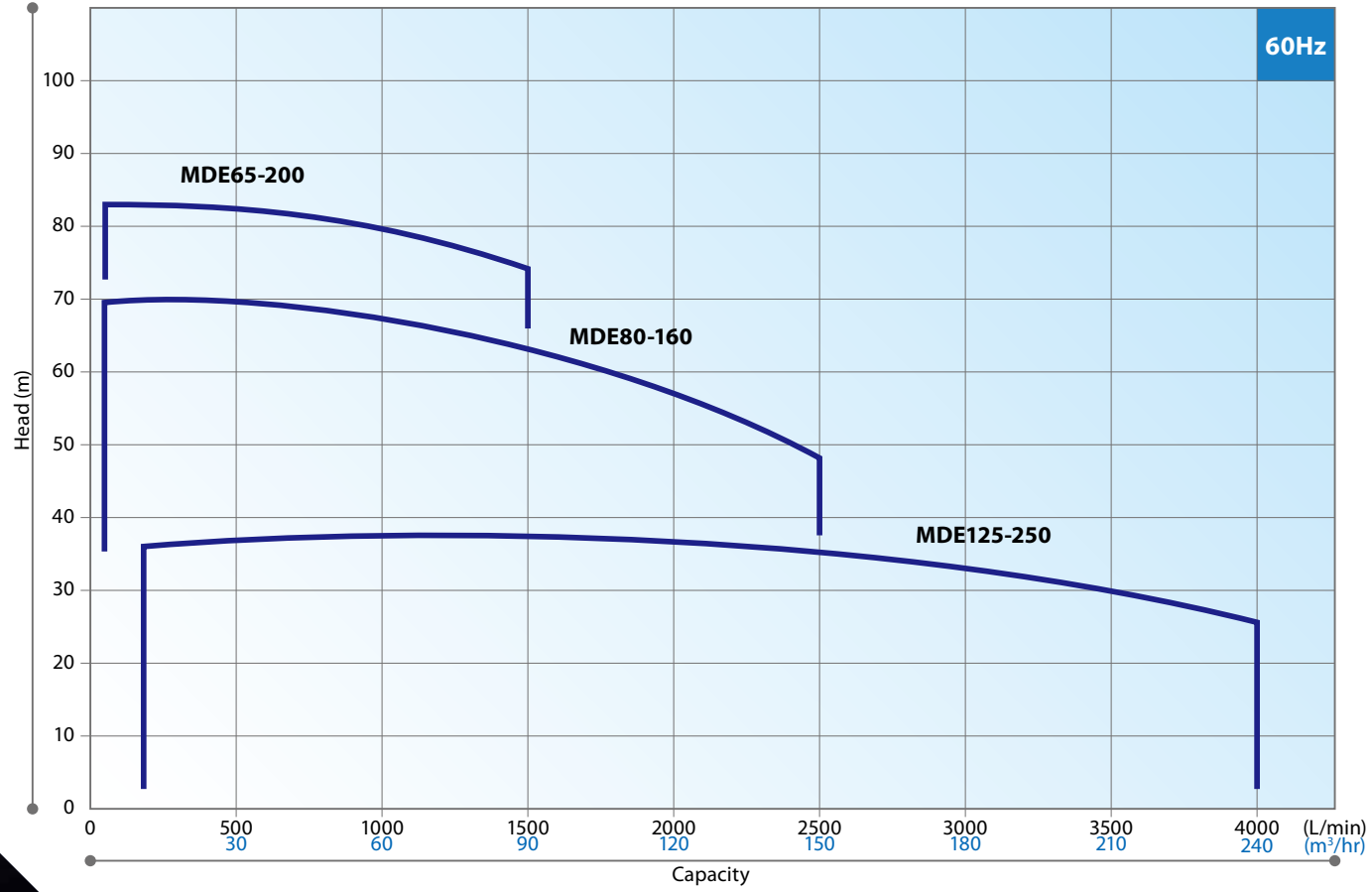
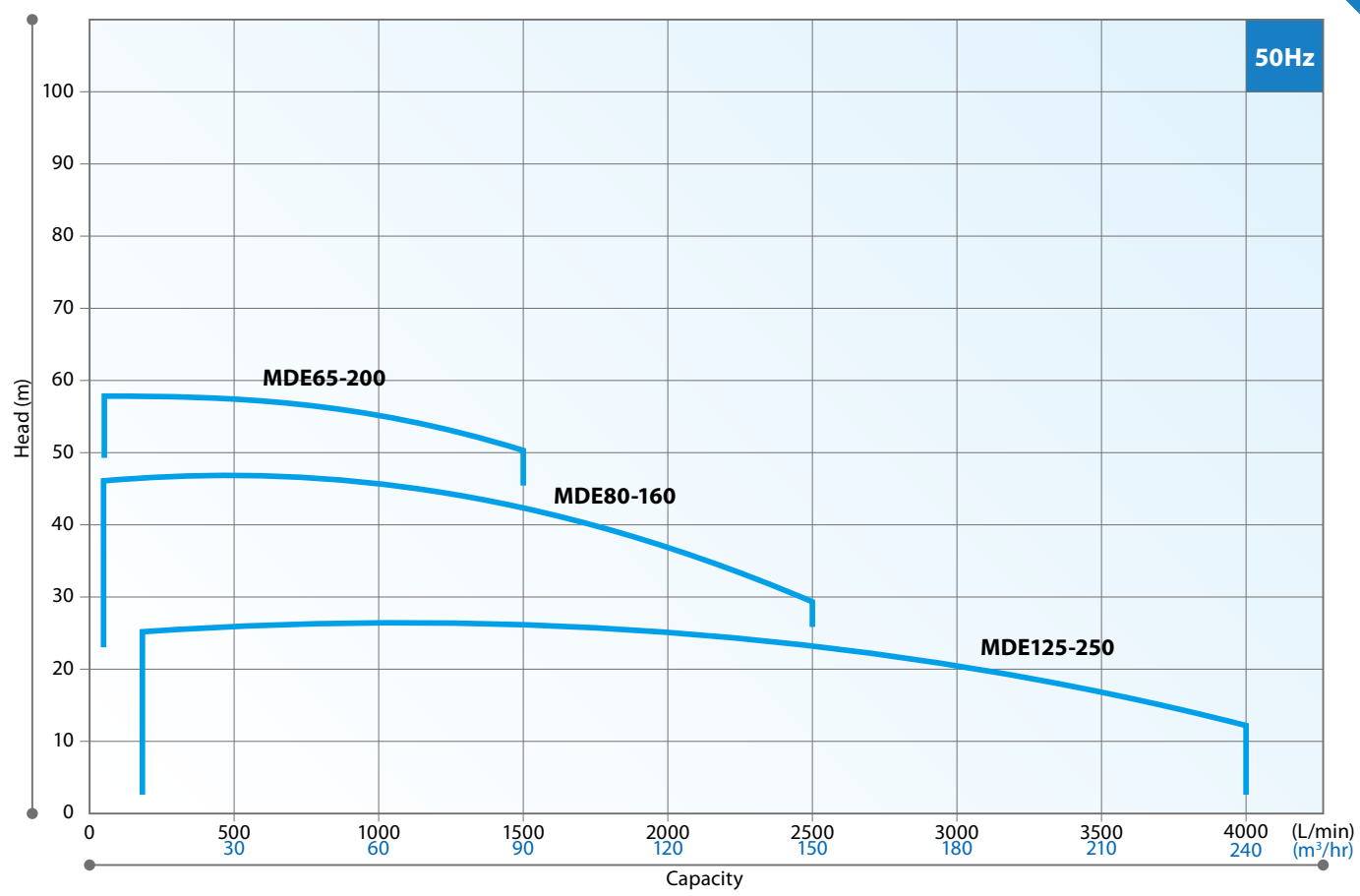

Performance curves

- Pump size (Suction×Discharge) MDM25: 40A×25A, MDM40: 50A×40A, MDM50: 65A×50A, MDM65: 80A×65A
- 2P: 2P poles motor, 4P: 4P poles motor

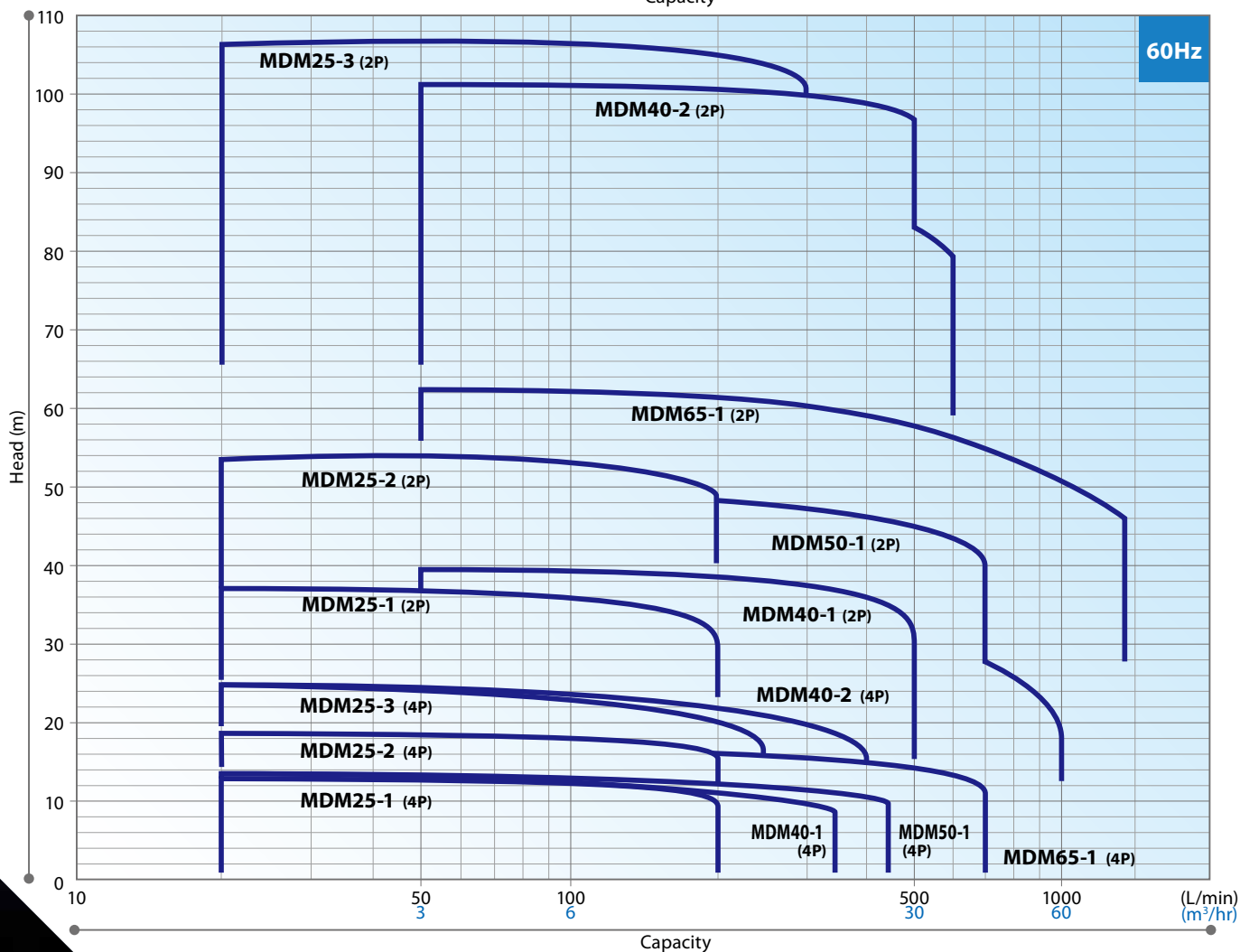
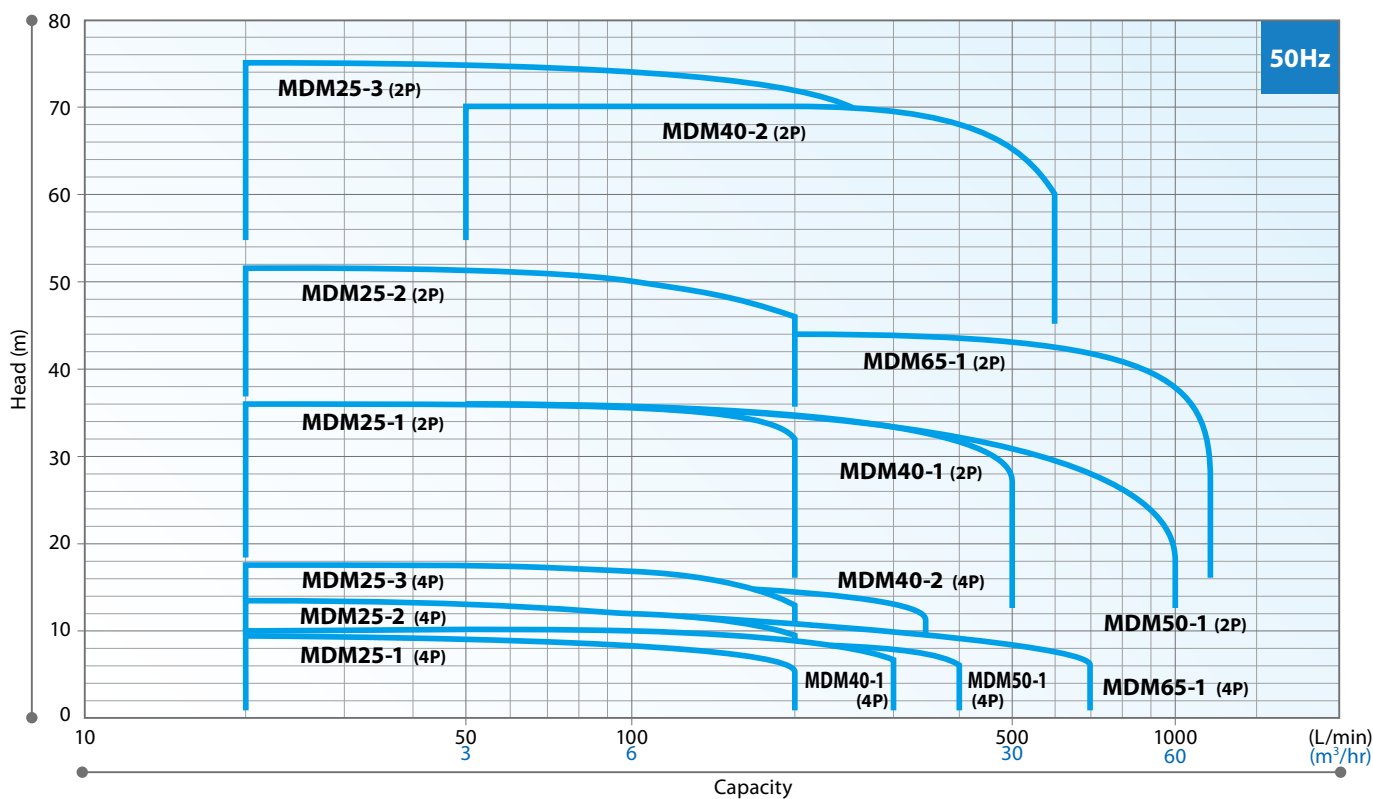



Liquid end material
CFRETFE

MXM series

- Withstands difficult operation
- Superior corrosion resistance
- Robust structure
- Enhanced safety



Specifications (50/60Hz)

Max. discharge capacity600 L/min
 Max. discharge head29/42 m
 MaterialCFRETFE
 Power range0.4 to 3.7kW
 Pump size (Discharge).....25A, 40A
 Liquid temp. range*1-10 to 90°C*2
 Specific-gravity limit2.0

(For details, please contact Iwaki.)

Sealing methodSeal-less construction

*1: Operating temperature for the pumps with an Aflas® O-ring should be 10°C or more. Fluid dependent.
 *2: -10 to 100°C for high temperature type

Liquid end materials

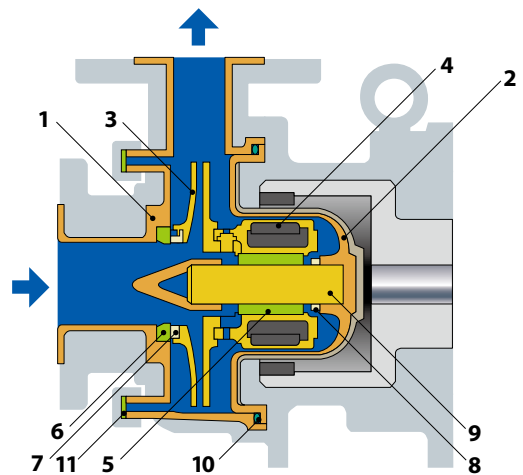

- 1 Front casing CFRETFE
- 2 Rear casing CFRETFE
- 3 Impeller CFRETFE
- 4 Magnet capsule CFRETFE
- 5 Bearing High density carbon,
High purity alumina ceramic, SiC
- 6 Liner ring High purity alumina ceramic, SiC
- 7 Mouth ring PTFE (with filler), SiC
- 8 Rear thrust CFRETFE, CFRPFA
- 9 Spindle High purity alumina ceramic, SiC
- 10 O ring FKM, EPDM, AFLAS®
DAI-EL PERFLUORO®
- 11 Gasket FKM, EPDM, AFLAS®
DAI-EL PERFLUORO®

**Magnetic drive pumps
with an excellent balance
of features and performance**

Performance curves

• Pump size (Suction×Discharge)

MXM22: 25A×25A, MXM44: 40A×40A, MXM54: 50A×40A

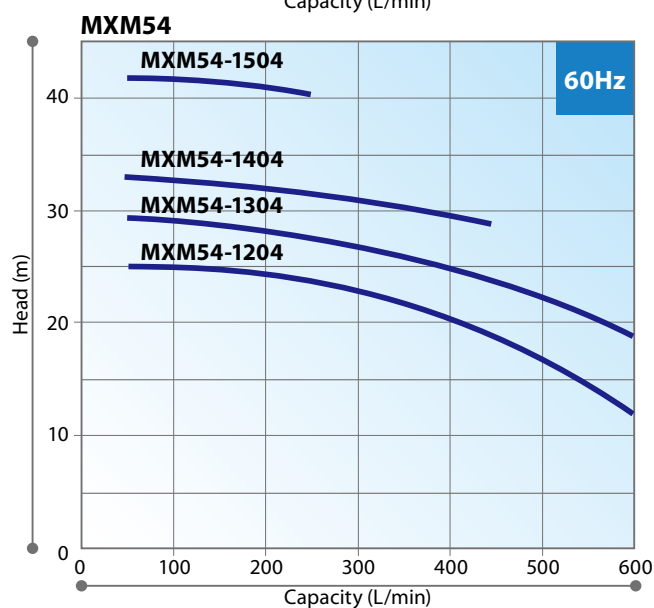
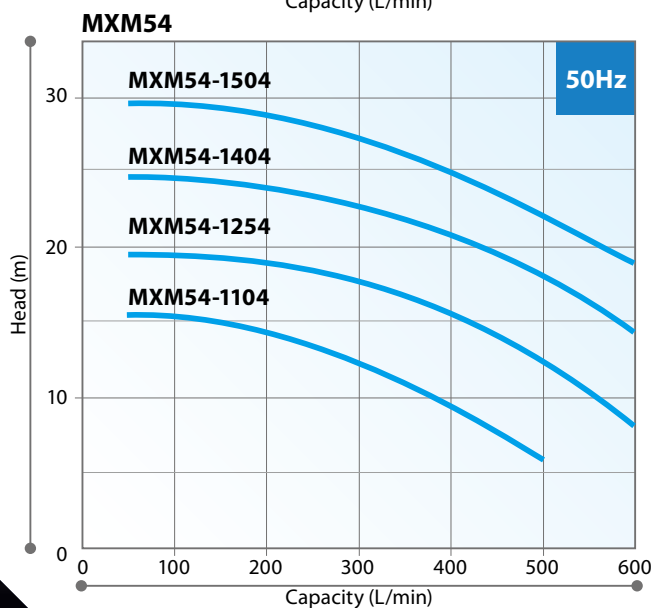
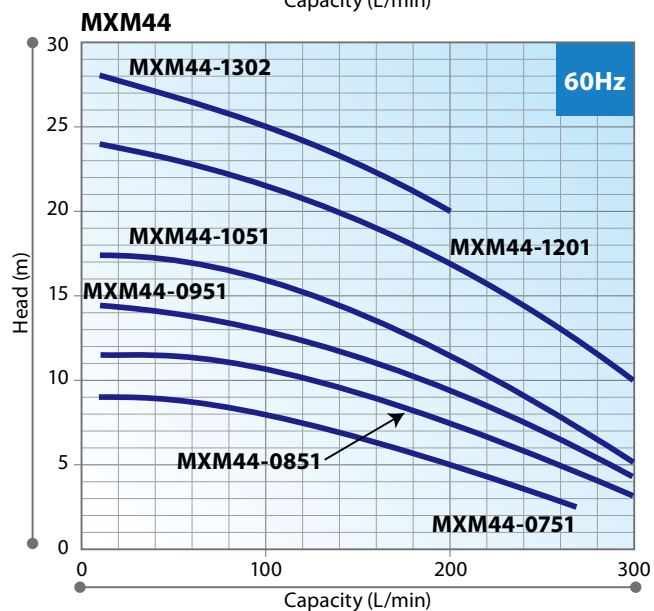
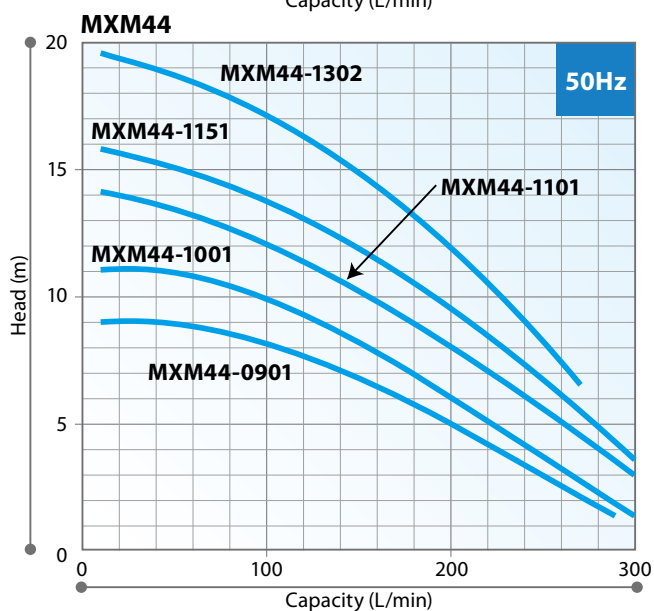
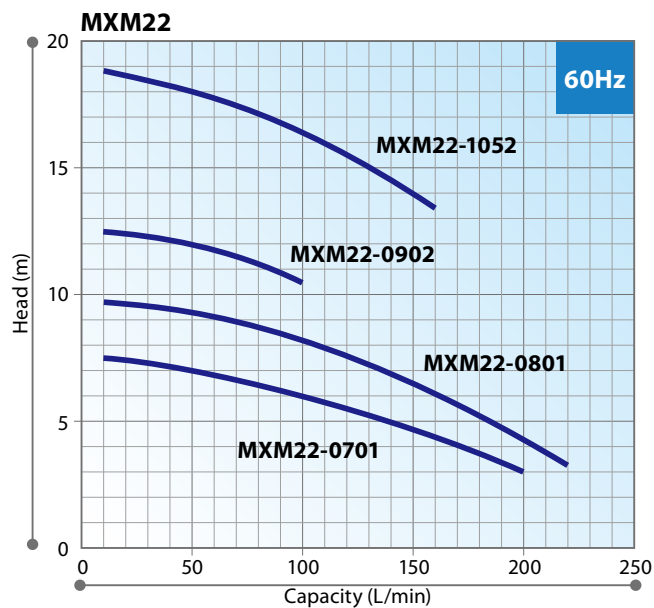
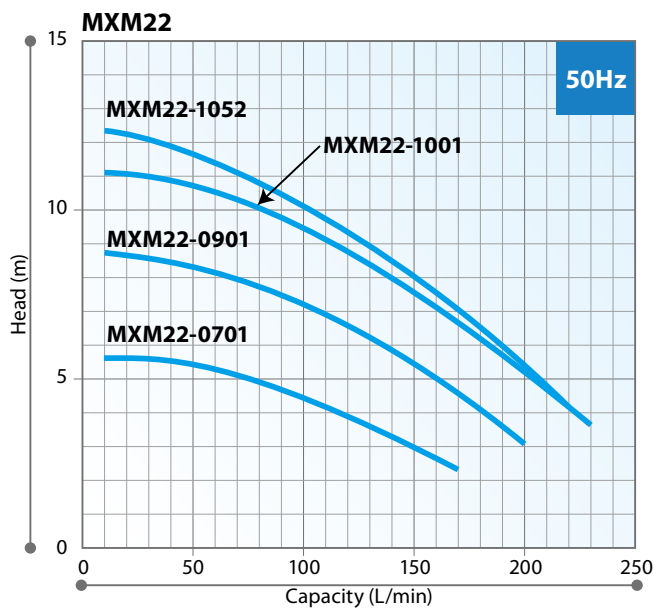

• High-lift/small-flow impellers are also available. Please contact us for more information.

CFRETFE
SMX-F



Liquid end material
CFRETFE

SMX-F series

- Excellent corrosion resistance
- Expanded versatility
- Easy maintenance
- Able to withstand abnormal operation
- Fast self-priming

Specifications (50/60Hz)

Max. discharge capacity440/520 L/min
 Max. discharge head.....24.5/35 m
 Rated self-priming height....4m
 MaterialCFRETFE
 Power range0.4 to 3.7kW
 Pump size (Discharge).....25A, 40A
 Liquid temp. range0 to 80°C*
 Specific-gravity limit2.0
 (For details, please contact Iwaki.)
 Sealing methodSeal-less construction

*Fluid dependent.

Liquid end materials

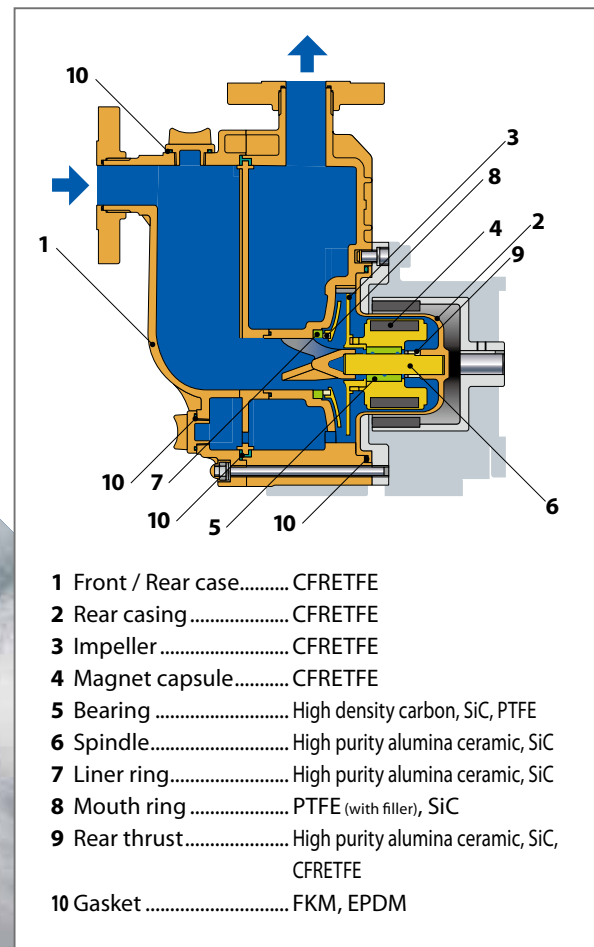

**Chemically resistant self-priming
magnetic drive pumps built to
withstand abnormal operation**

Performance curves

• Pump size (Suction×Discharge)

SMX-F22: 25A×25A, SMX-F44: 40A×40A, SMX-F54: 50A×40A

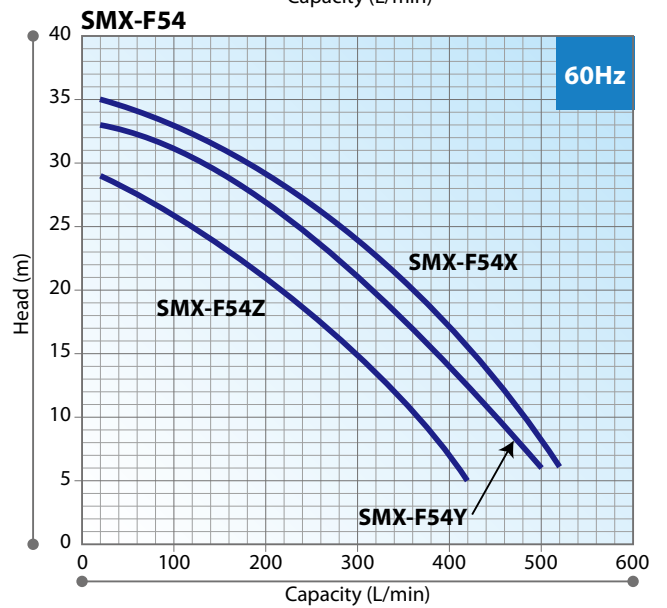
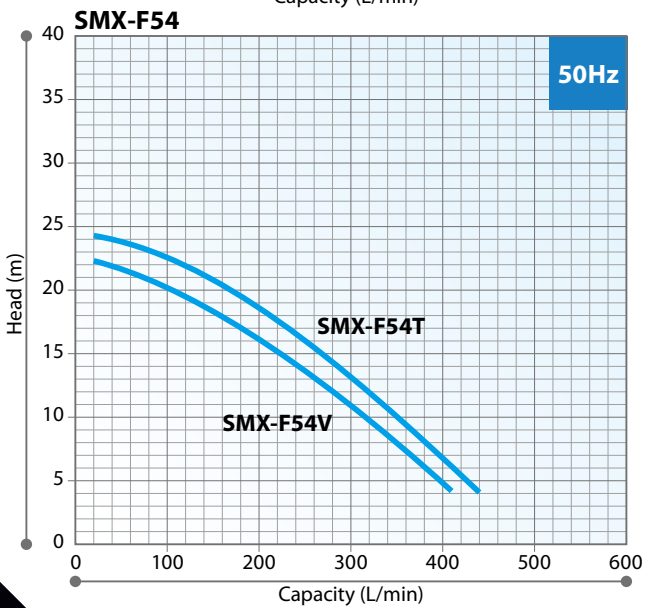
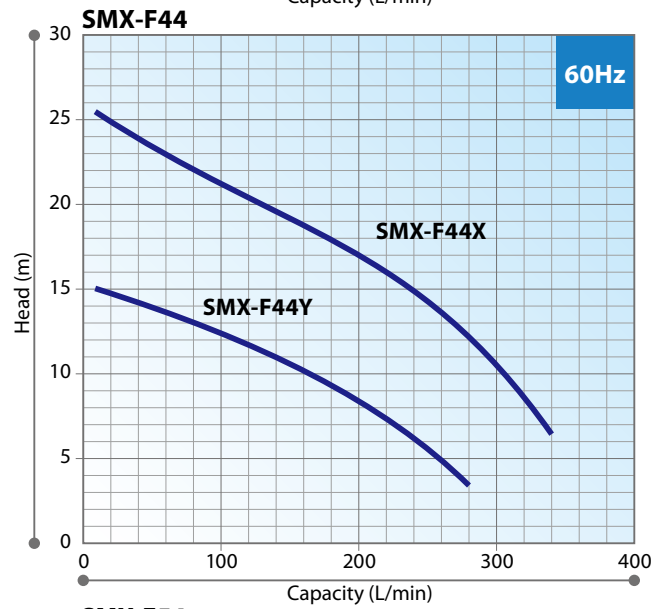
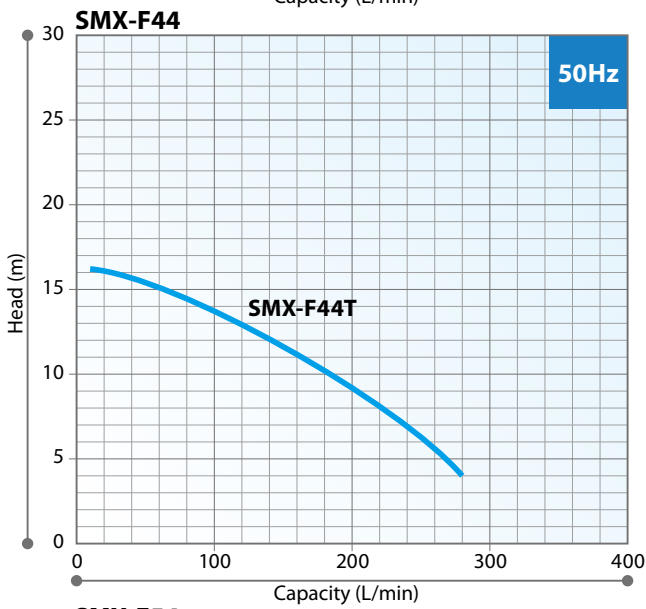
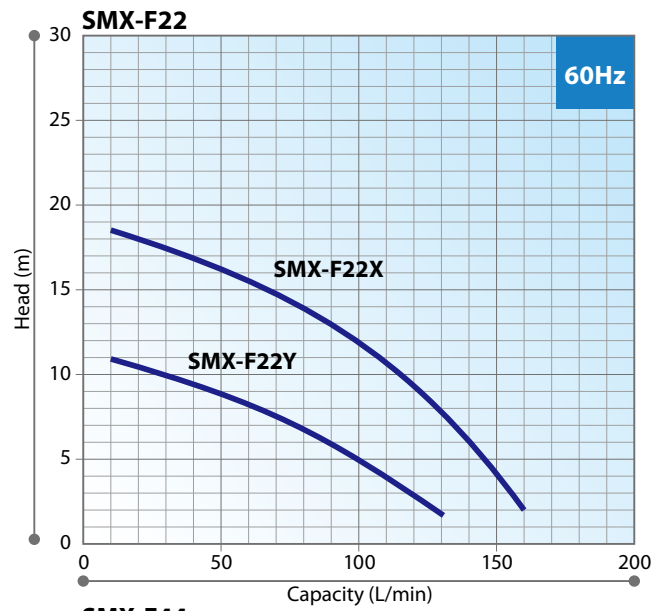
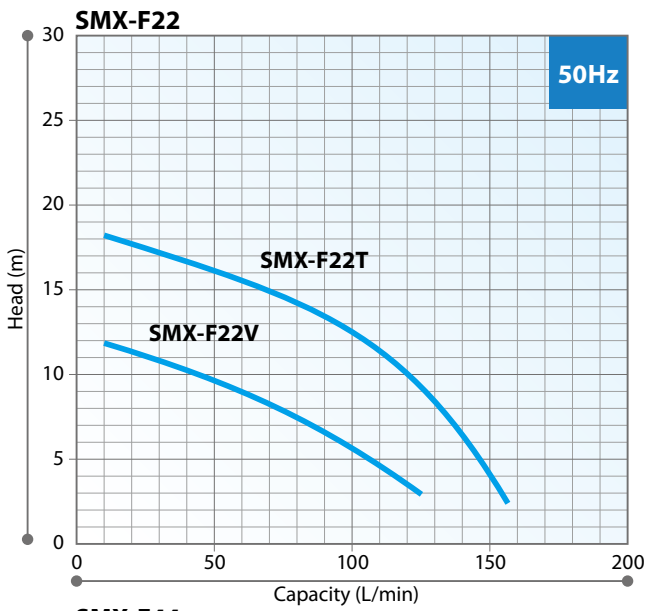



Liquid end material
CFRETFE

MX-F series

- Self-radiating structure (PAT.)
- Dual section volute casing (PAT.)
- Robust structure
- Excellent chemical resistance

Chemically resistant magnetic drive pumps built to withstand abnormal operation

Specifications (50/60Hz)

Max. discharge capacity510 L/min
 Max. discharge head.....29.5/27 m
 MaterialCFRETFE
 Power range0.26 to 2.2kW
 Pump size (Discharge).....G1 to 40A
 Liquid temp. range0 to 80°C*
 Specific-gravity limit2.0
 (For details, please contact Iwaki.)
 Sealing methodSeal-less construction

*An Aflas® O-ring is 10 to 80°C.
 Fluid dependent.

Liquid end materials

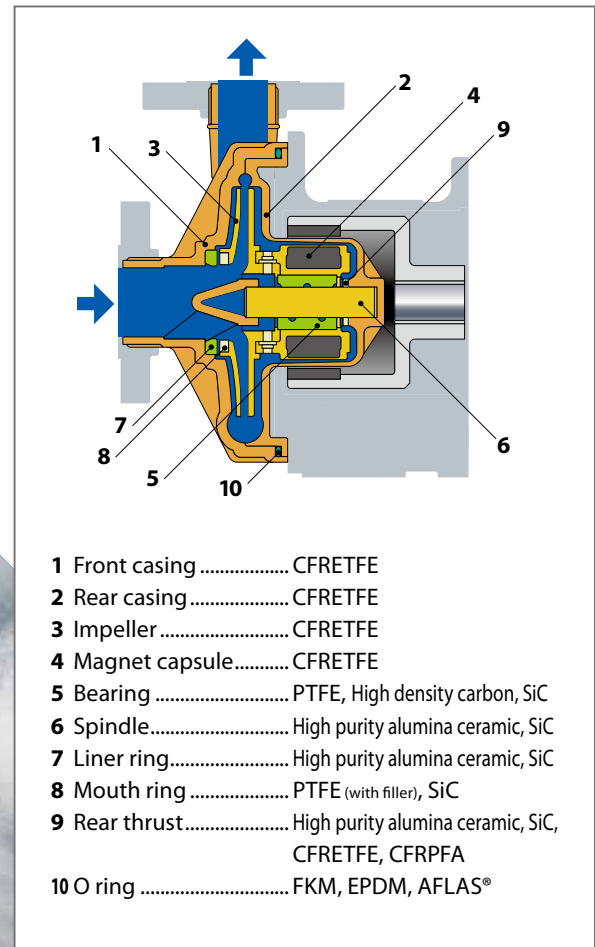

Performance curves

• Pump size (Suction×Discharge)

MX-F100: G1×G1, MX-F250/251: 25A×25A, MX-F400: 40A×40A

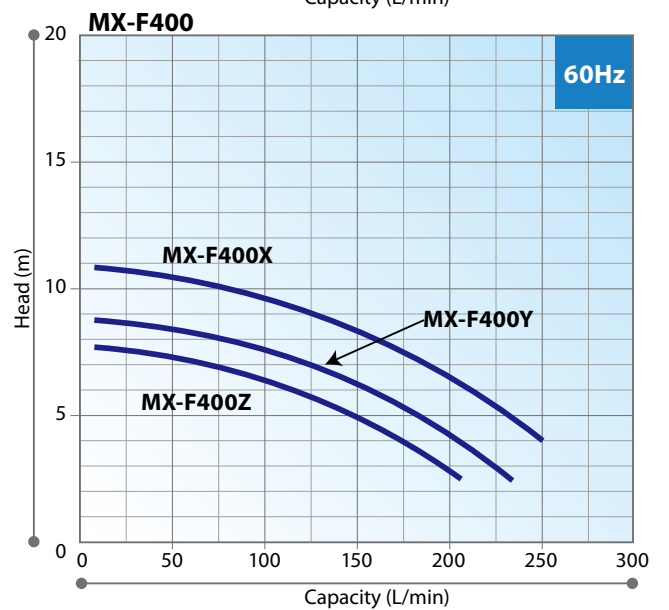
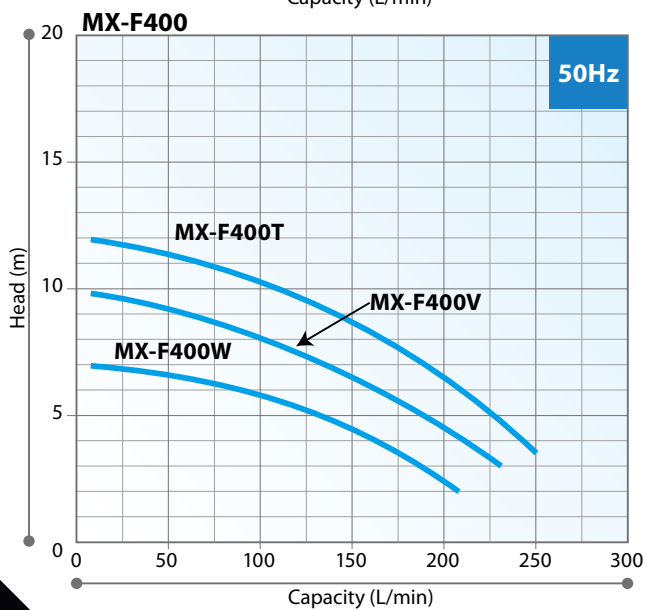
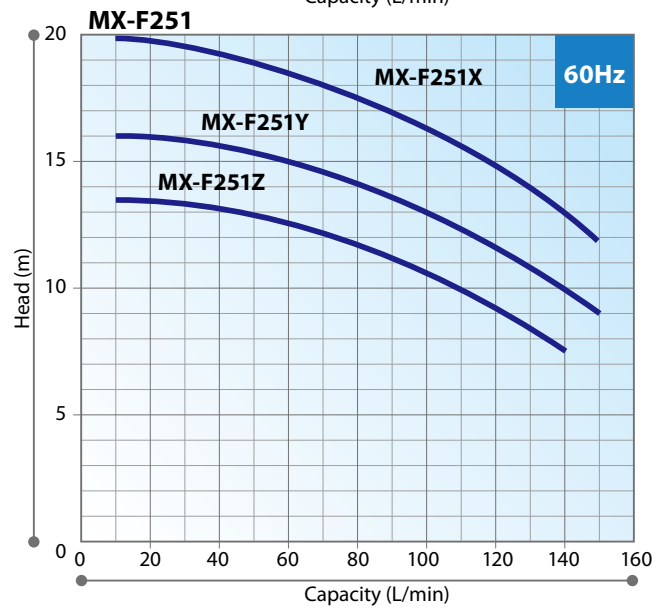
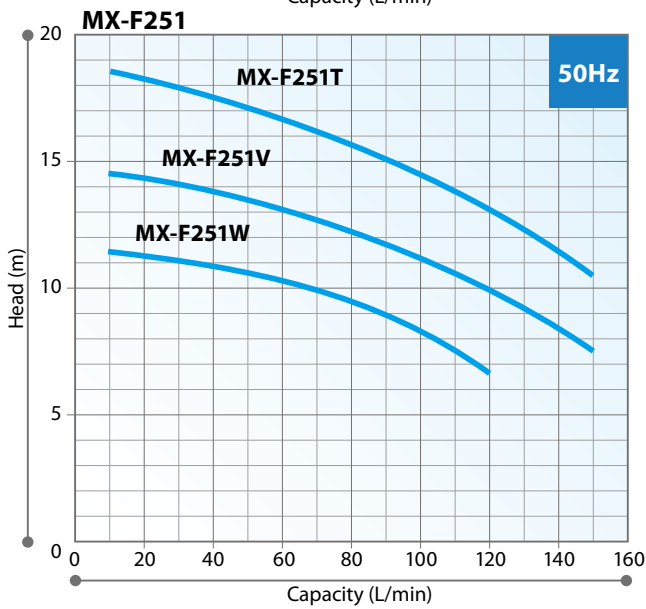
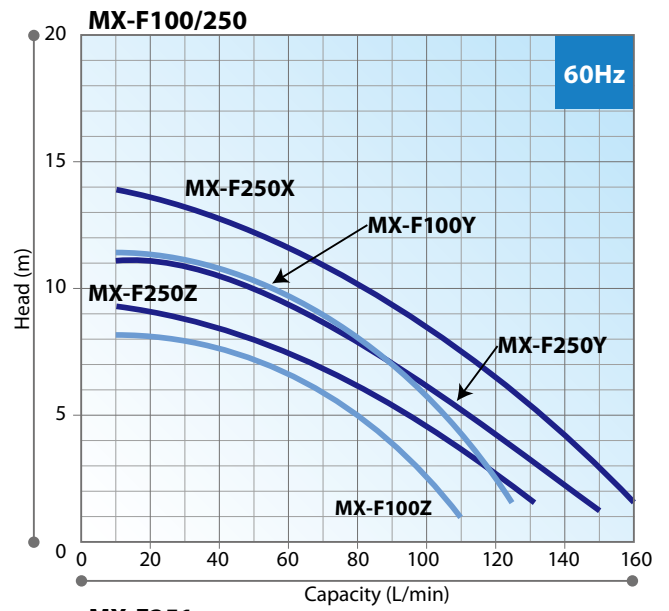
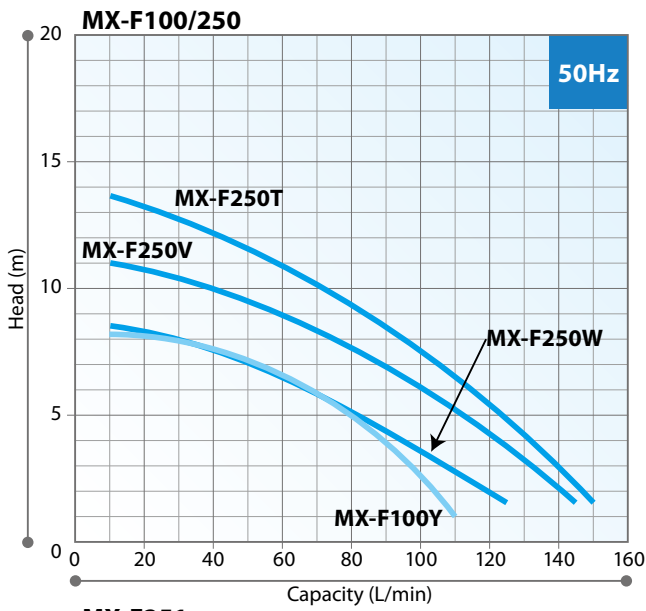

Continued

Performance curves

• Pump size (Suction×Discharge)

MX-F401: 40A×40A, MX-F402/403: 50A×40A

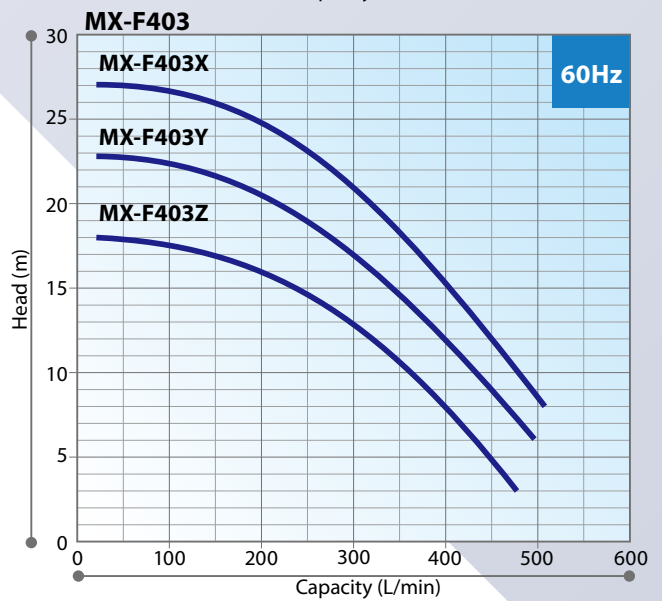
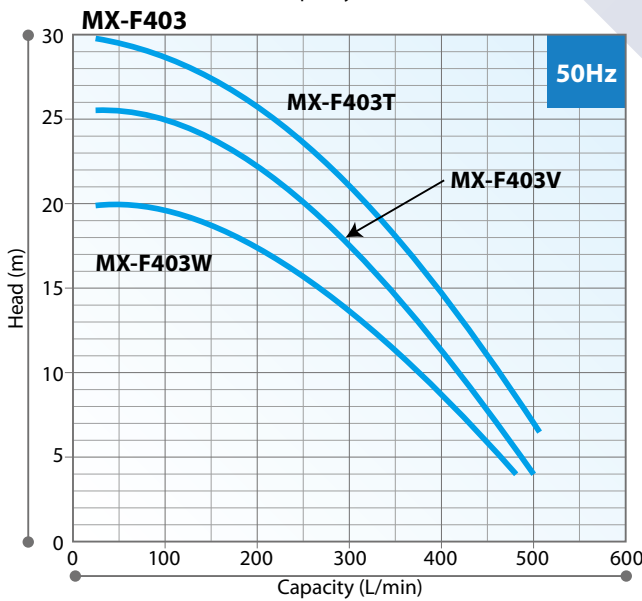
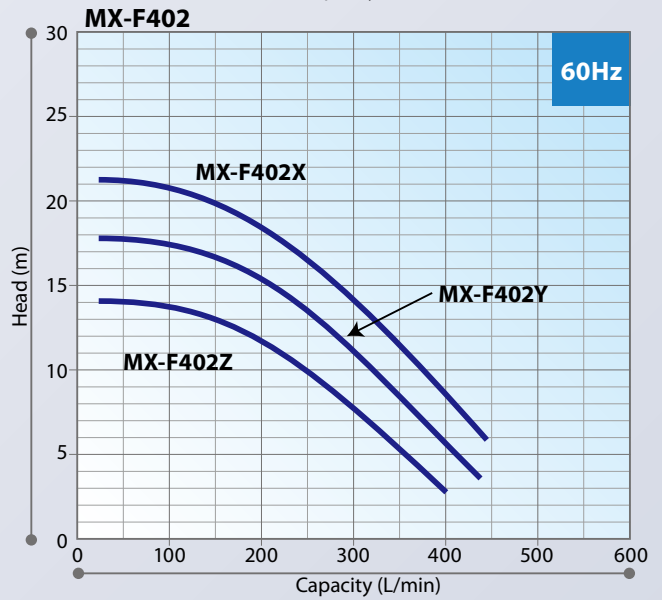
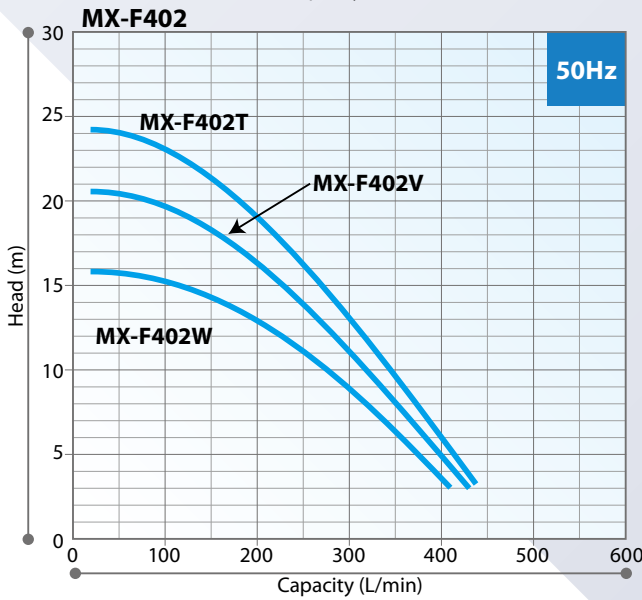
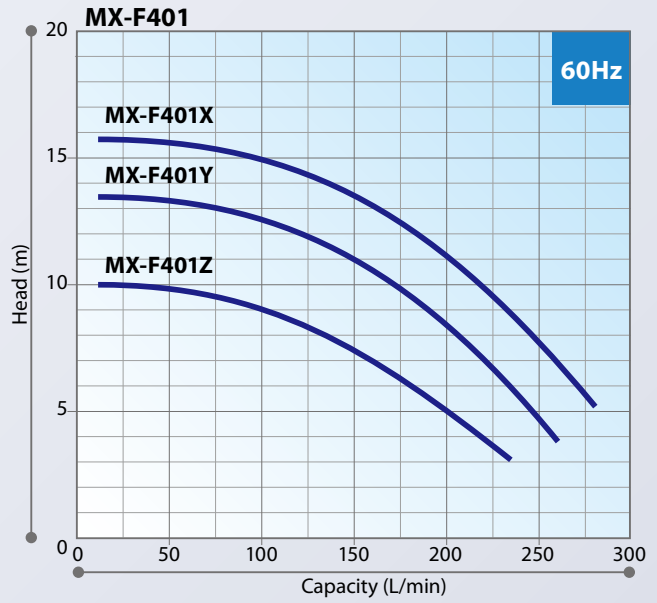
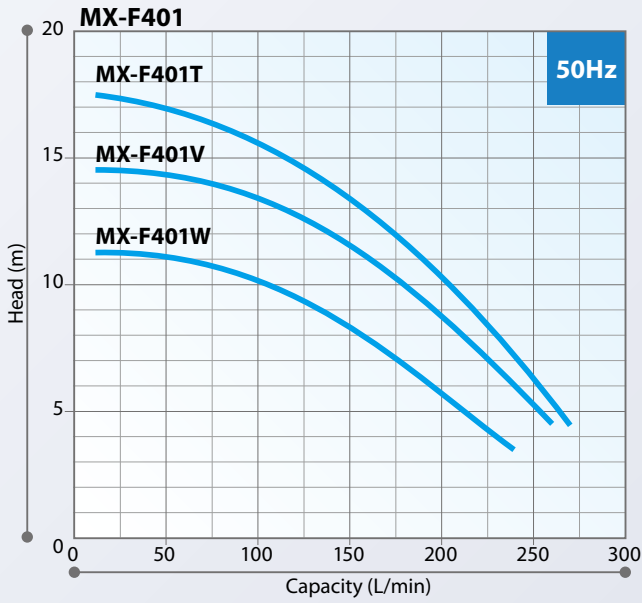



Liquid end
materials

CFRPP
GFRPP

Performance Comparison for Iwaki Magnetic Drive Pumps

Materials: Polypropylene (CFRPP/GFRPP)

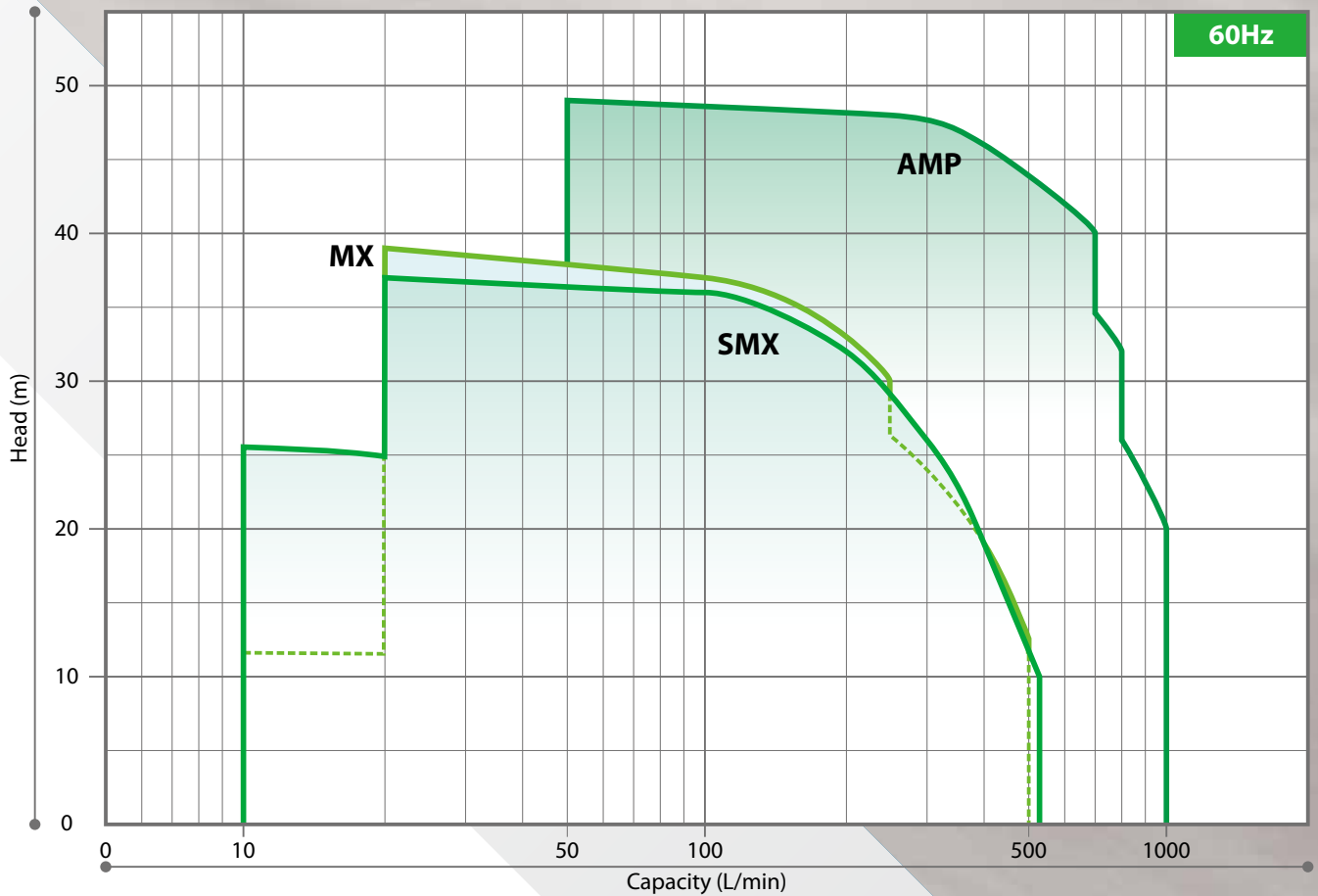
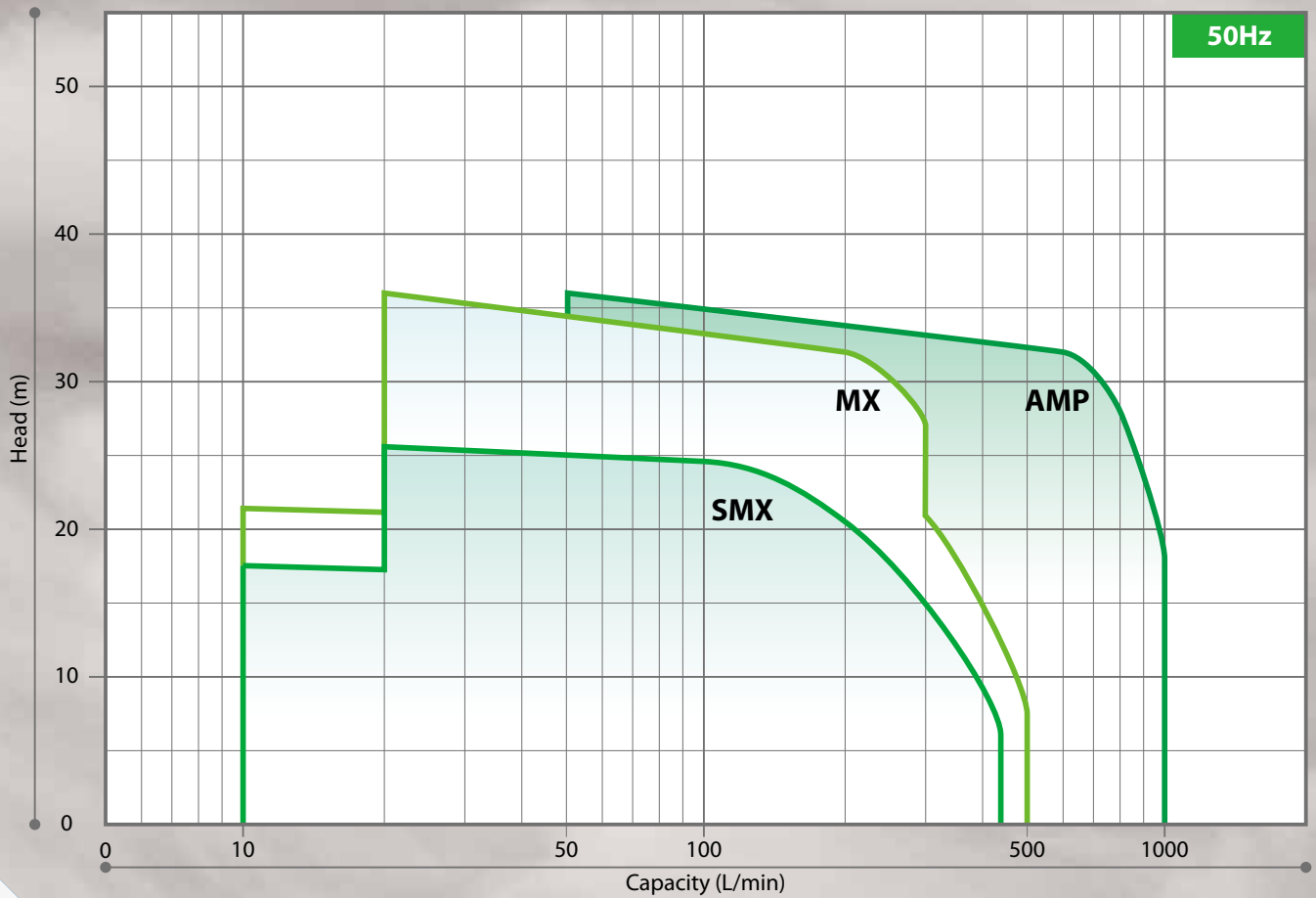

Liquid end Materials



AMP

CFRPP



SMX

GFRPP



MX

GFRPP

Polypropylene
(CFRPP/GFRPP)

Materials

Model	Resin parts				Sliding parts		Sealing parts	
	Front casing	Rear casing	Impeller	Magnet capsule	Bearing	Spindle	Gasket	O ring
AMP	CFRPP	CFRPP	CFRPP	CFRETFE	High density carbon SiC	High purity alumina ceramic SiC	PTFE	—
SMX	GFRPP	GFRPP	GFRPP	PP	Carbon PTFE SiC	High purity alumina ceramic SiC	FKM EPDM	FKM EPDM
MX	GFRPP	GFRPP	CFRPP GFRPP	PP	CFRPPS PTFE Carbon Alumina ceramic	Alumina ceramic High purity alumina ceramic	—	FKM EPDM

Material index

Plastic materials	
PP	Polypropylene
CFRPP	Carbon fiber-reinforced PP
GFRPP	Fiberglass-reinforced PP

Rubber	
FKM	Fluorine rubber
EPDM	Ethylene propylene rubber

Materials for sliding parts/bearings	
Carbon	Carbon
High-density carbon	Hard carbon
Ceramic	Alumina ceramic
Highly pure ceramic	Alumina ceramic with a purity of 99.5% or more
SiC	Silicon carbide ceramic

CFRPP
AMP



Liquid end material
CFRPP

AMP series

- Highly durable structure
- Unique design prevents abnormal operation
- Back pullout design
- Modular design and low maintenance costs

Polypropylene magnetic drive process pumps

Specifications (50/60Hz)

Max. discharge capacity 1000 L/min
Max. discharge head 36/49 m
Material CFRPP
Power range 3.7 to 7.5kW
Pump size (Discharge) 40A, 50A
Liquid temp. range 0 to 80°C*
Specific-gravity limit 2.0
(For details, please contact Iwaki.)
Sealing method Seal-less construction
*Fluid dependent.

Liquid end materials

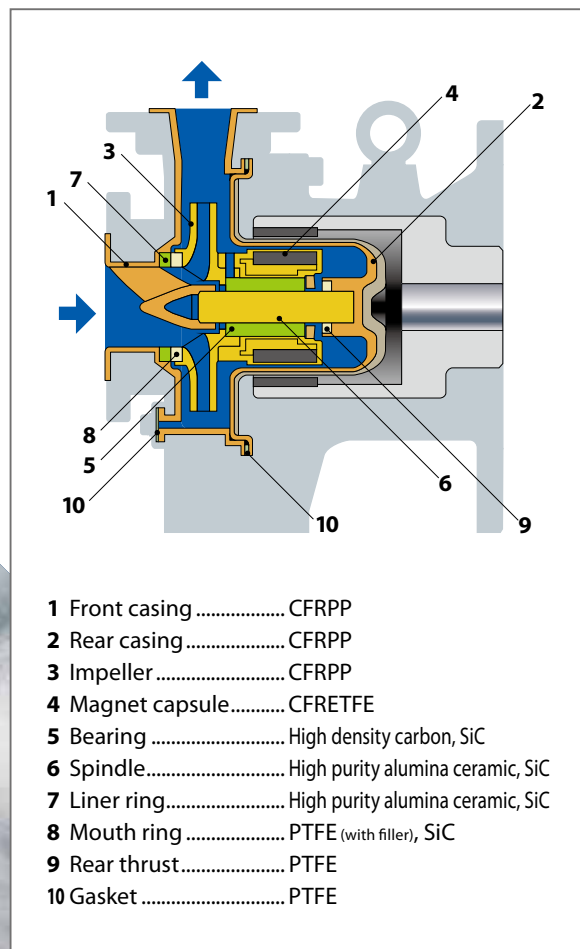

Performance curves

• Pump size (Suction×Discharge)

AMP40: 50A×40A, AMP50: 65A×50A

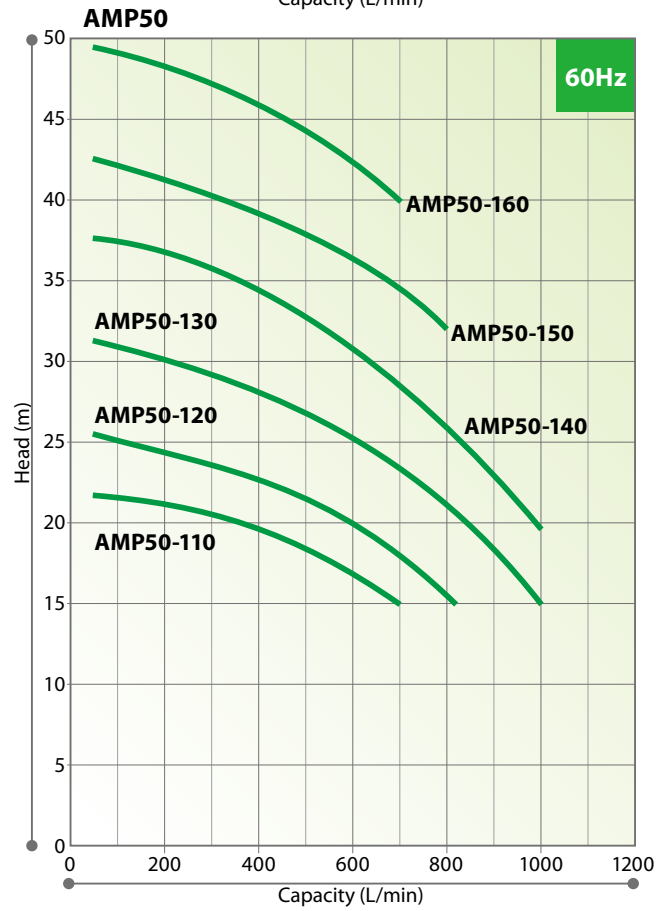
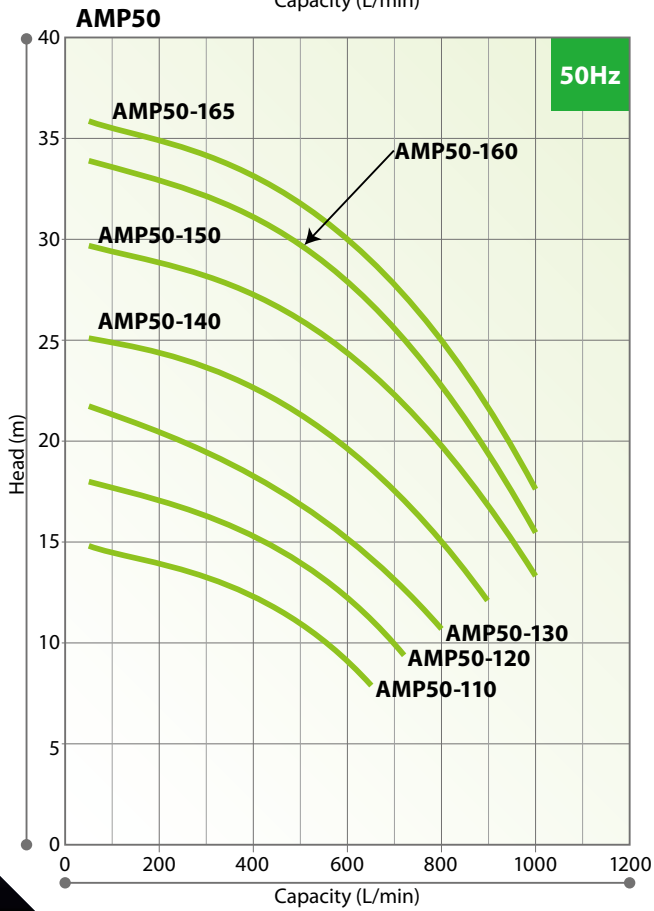
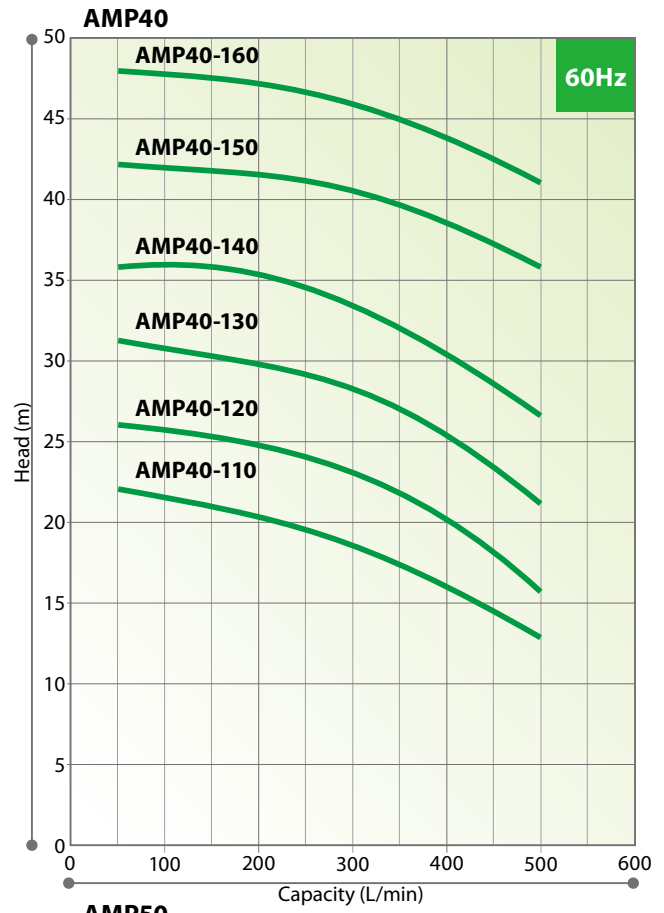
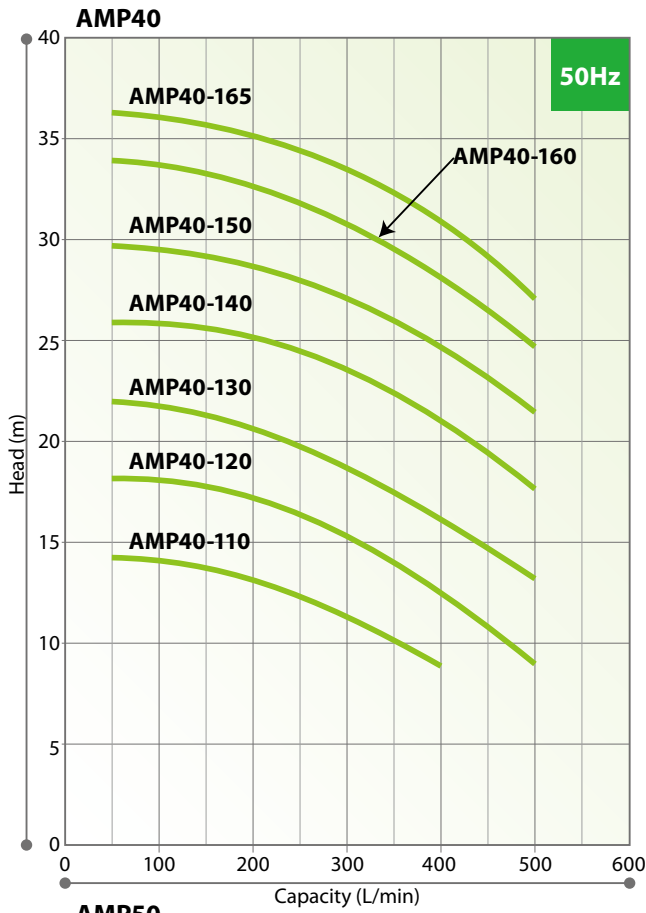



Liquid end material
GFRPP

SMX series

- Expanded versatility
- Easy maintenance
- Able to withstand abnormal operation
- Fast self-priming



Specifications (50/60Hz)

Max. discharge capacity440/520 L/min
 Max. discharge head.....25.5/37.5 m
 Rated self-priming height....4m
 MaterialGFRPP
 Power range0.4 to 3.7kW
 Pump size (Discharge).....25A, 40A
 Liquid temp. range0 to 80°C*
 Specific-gravity limit2.0
 (For details, please contact Iwaki.)
 Sealing methodSeal-less construction

*Fluid dependent.

Liquid end materials

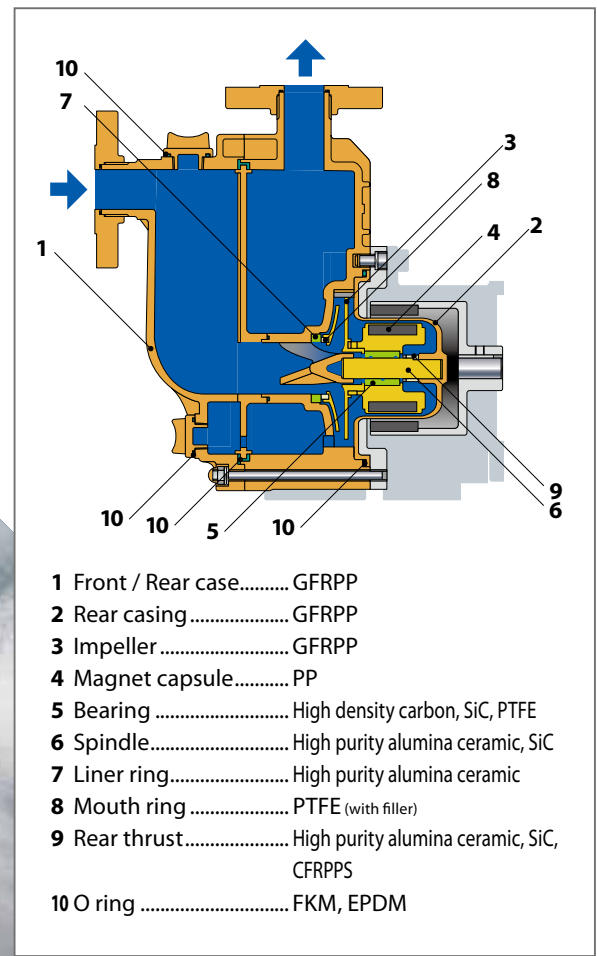

- 1 Front / Rear case..... GFRPP
- 2 Rear casing..... GFRPP
- 3 Impeller..... GFRPP
- 4 Magnet capsule..... PP
- 5 Bearing High density carbon, SiC, PTFE
- 6 Spindle..... High purity alumina ceramic, SiC
- 7 Liner ring..... High purity alumina ceramic
- 8 Mouth ring PTFE (with filler)
- 9 Rear thrust..... High purity alumina ceramic, SiC, CFRPPS
- 10 O ring FKM, EPDM

**Versatile self-priming
magnetic drive pumps built to
withstand abnormal operation**

Performance curves

• Pump size (Suction×Discharge)

SMX22: 25A×25A, SMX44: 40A×40A, SMX54: 50A×40A

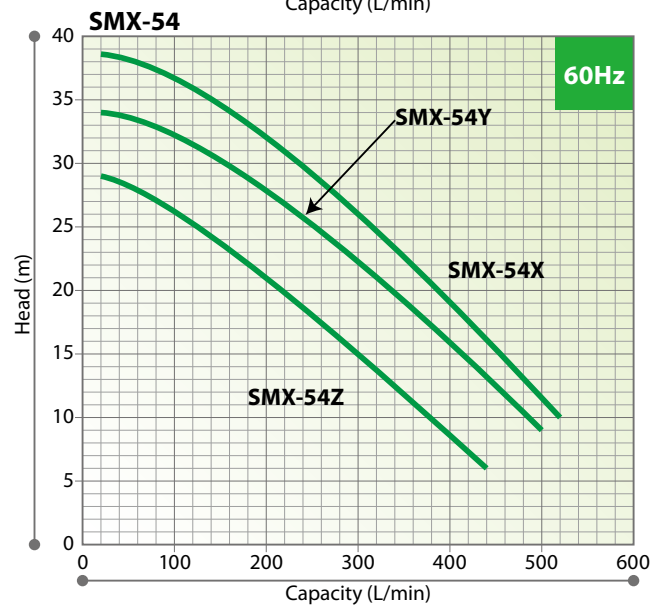
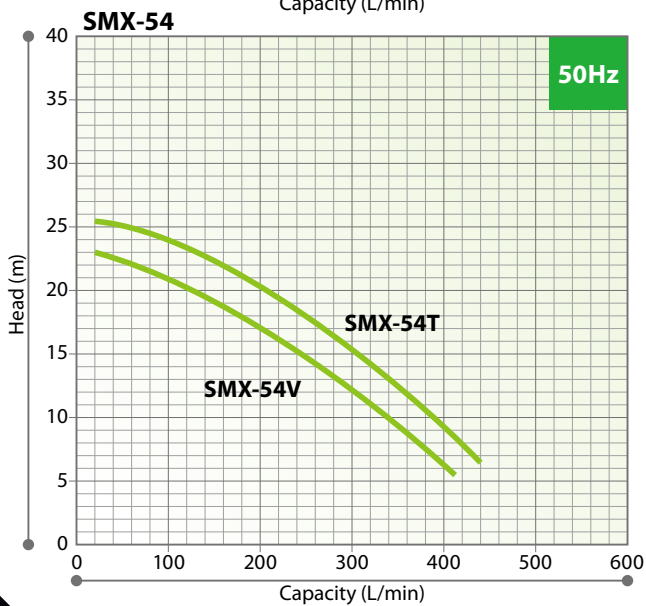
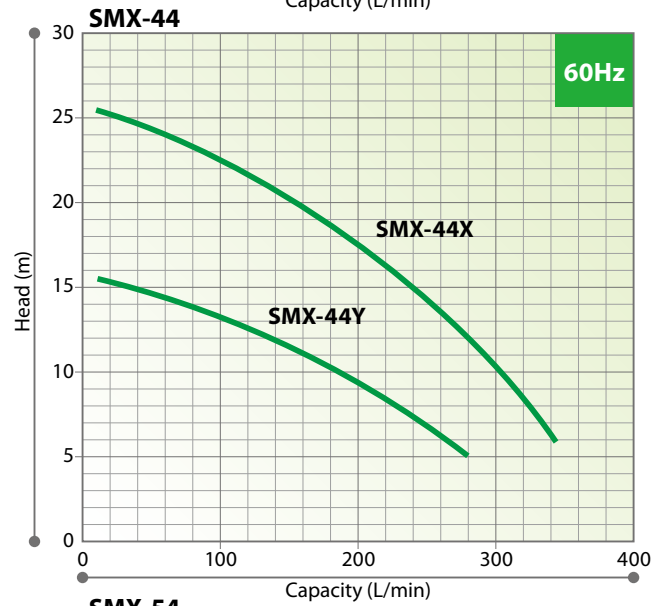
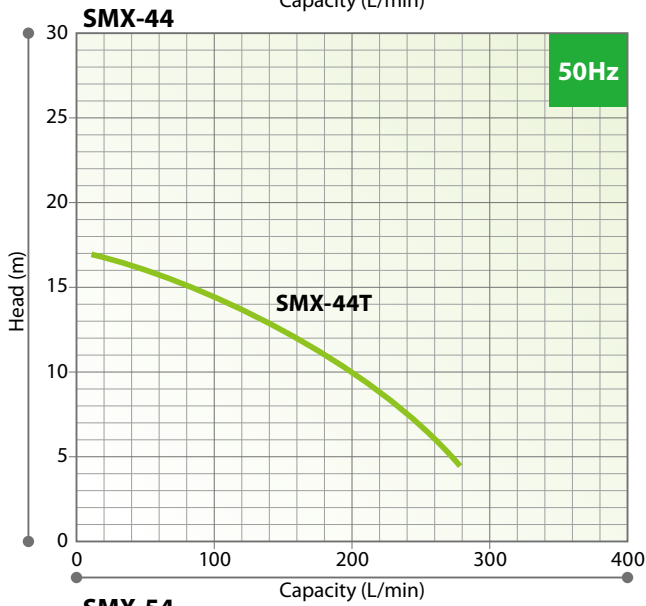
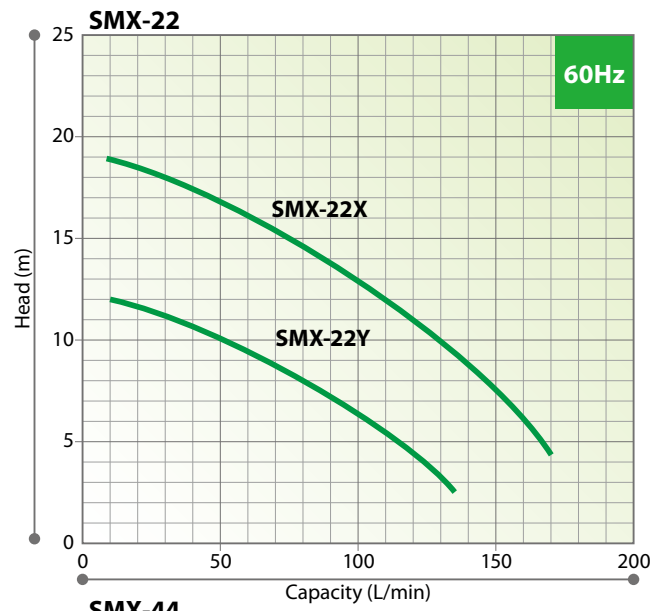
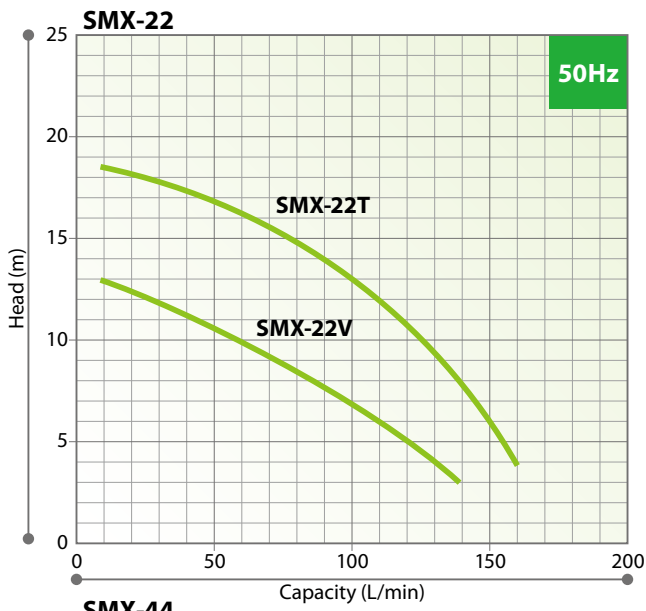



Liquid end material
GFRPP

MX series

- Self-radiating structure (PAT.)
- Non-contact structure
- Dual section volute casing (PAT.)
- Robust structure

Specifications (50/60Hz)

Max. discharge capacity500 L/min
 Max. discharge head.....35/37 m
 MaterialGFRPP
 Power range0.15 to 2.2kW
 Pump size (Discharge).....G1 to 40A
 Liquid temp. range0 to 80°C*
 Specific-gravity limit2.0
 (For details, please contact Iwaki.)
 Sealing methodSeal-less construction

*An Aflas® O-ring is 10 to 80°C.
 Fluid dependent.

Liquid end materials

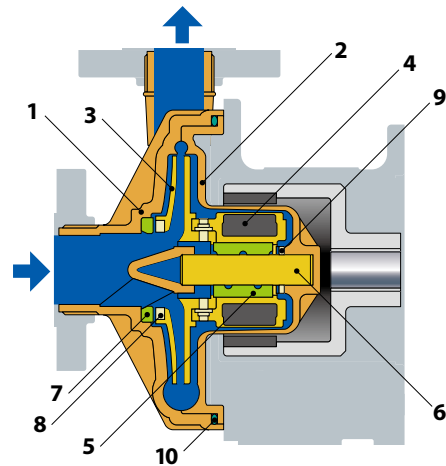

- 1 Front casing GFRPP
- 2 Rear casing GFRPP
- 3 Impeller GFRPP
- 4 Magnet capsule..... PP
- 5 Bearing CFRPPS, PTFE, High density carbon,
High purity alumina ceramic
- 6 Spindle..... High purity alumina ceramic
- 7 Liner ring..... High purity alumina ceramic
- 8 Mouth ring PTFE (with filler)
- 9 Rear thrust..... CFRPPS*
- 10 O ring FKM, EPDM, AFLAS®

*MX-402, 402H, 403, 403H is CFRPEEK.

**Built to withstand
abnormal operation
and provide high efficiency**

Performance curves

• Pump size (Suction×Discharge)

MX-70/100: G1×G1, MX250/251: 25A×25A, MX400: 40A×40A

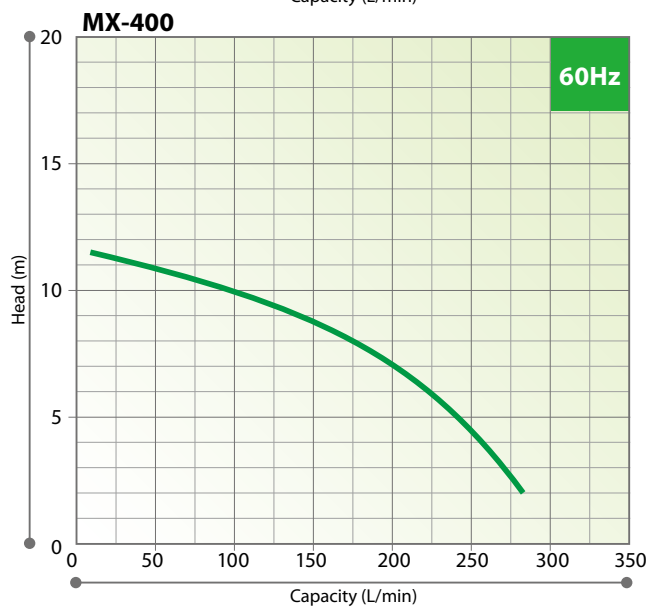
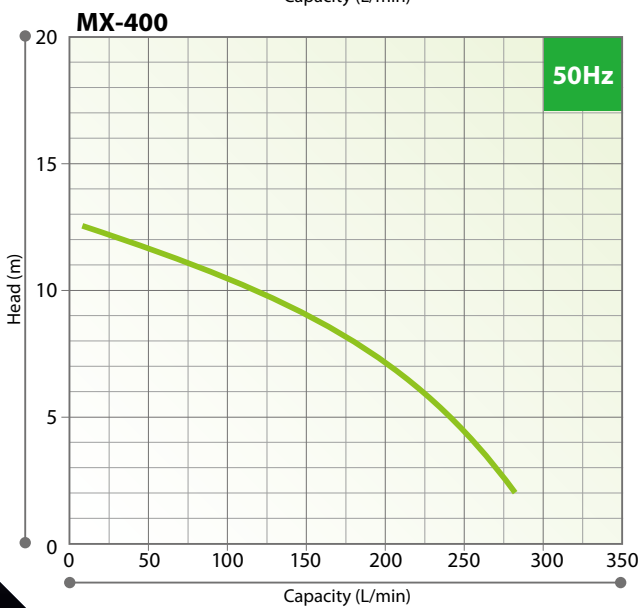
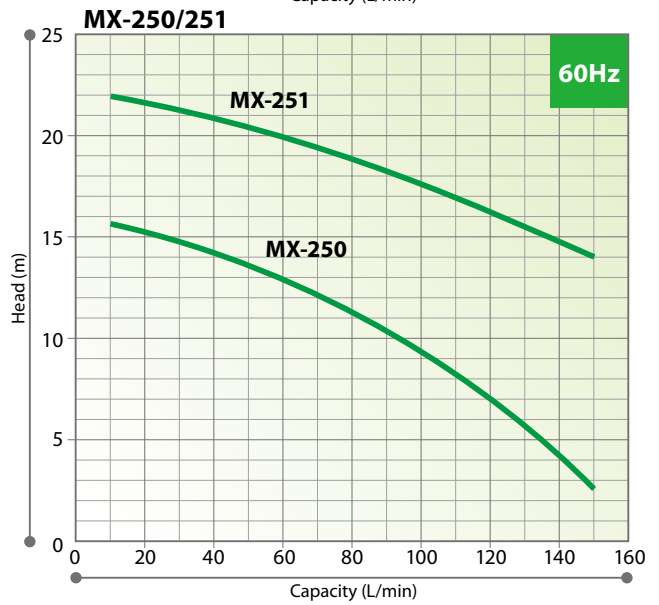
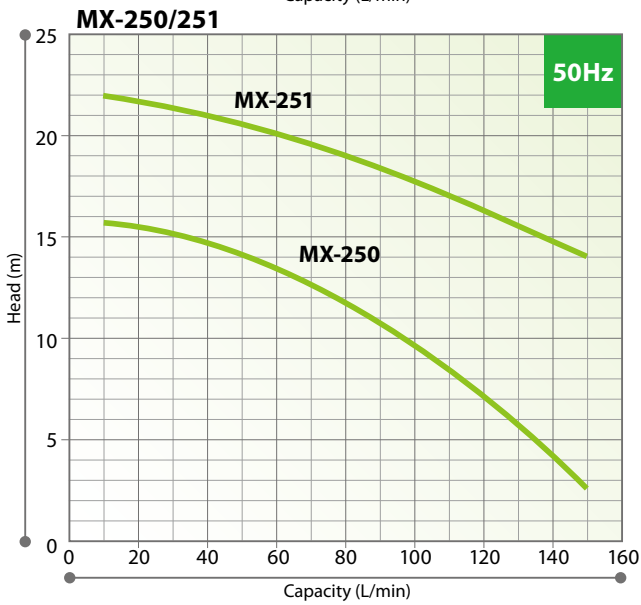
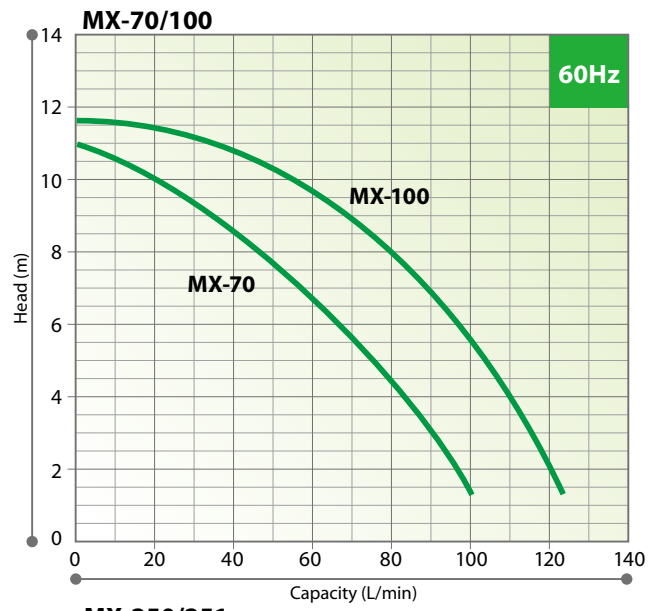
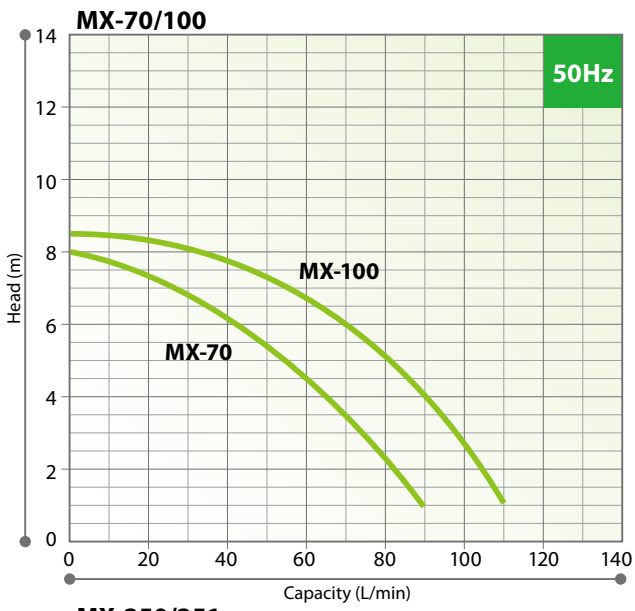

Continued

Performance curves

• Pump size (Suction×Discharge)

MX-401: 40A×40A, MX402/402H/403/403H: 50A×40A

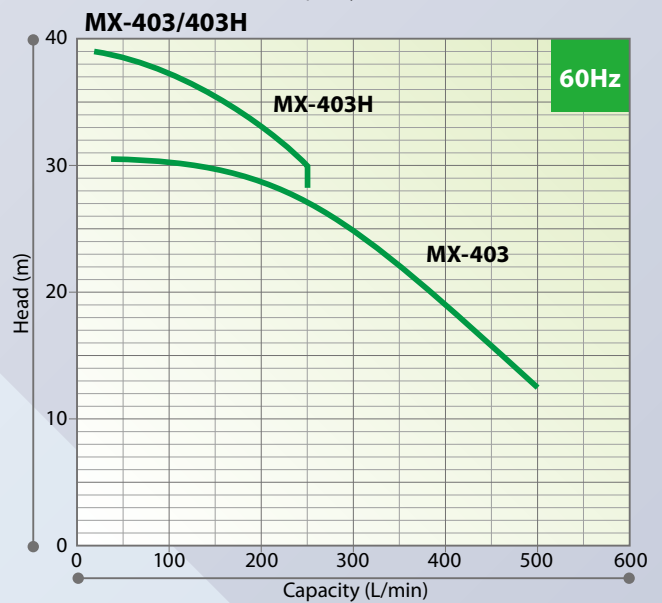
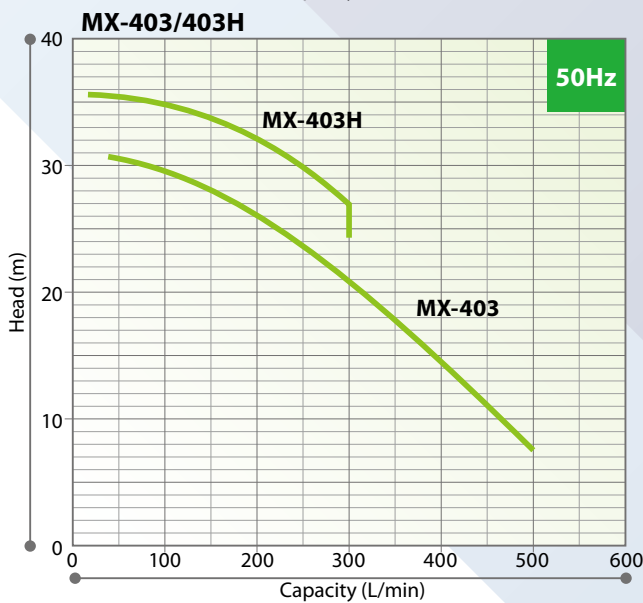
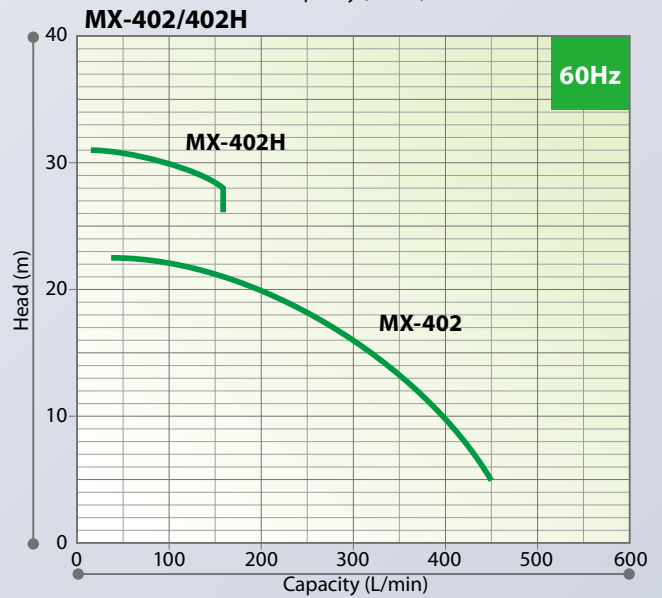
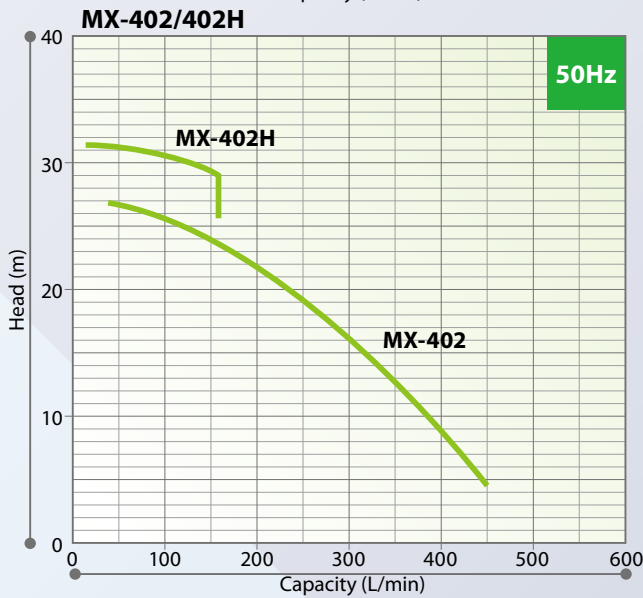
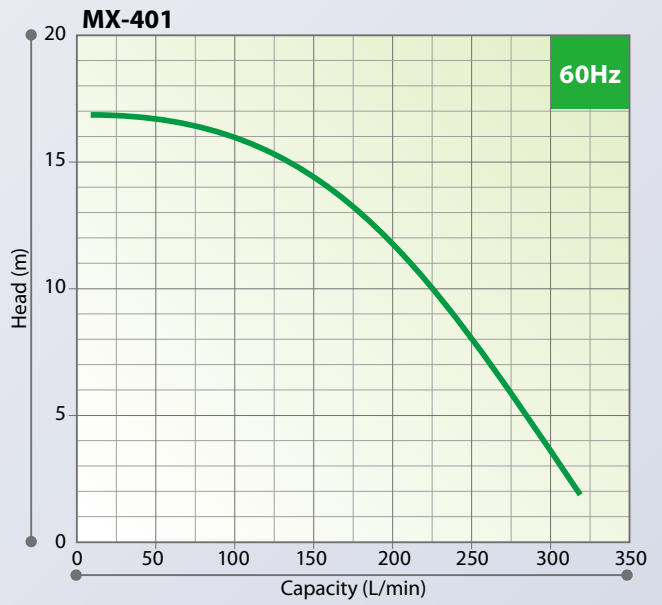
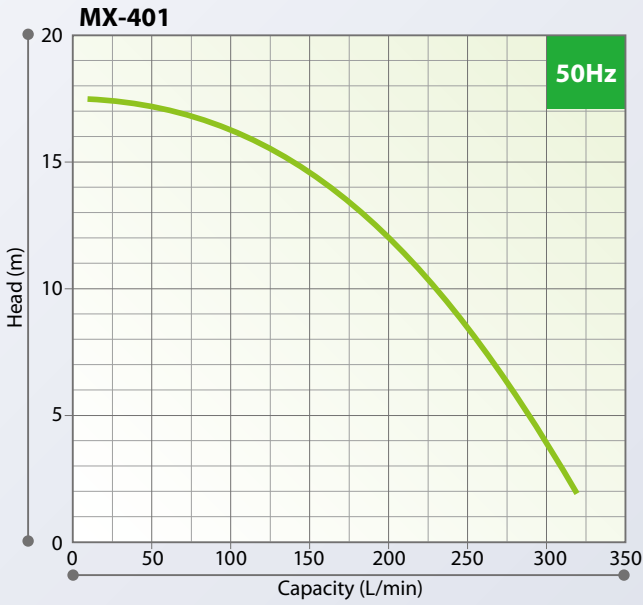

Installation Precautions

To safely use the full capability of a pump, observe the precautions below when performing installation. Note that there are restrictions on pipe arrangements for the SMX and SMX-F models, as they are self-suction pumps. Please contact us for each product individually.

Suction Piping

1. The suction pipe should employ the flooded suction method if possible. The shortest pipe possible, with the minimum number of bends, should be designed. Arrange a proper support on the suction pipe so that load and the thermal stress of the pipe itself are not applied to the pump.
2. Attach the coupling on the suction pipe carefully, so that no air enters the line. The presence of air in the suction pipe may prevent priming of the pump.
3. Avoid installations with poor suction conditions (e.g. vacuum in suction tank, large suction head or long suction piping). NPSHa should always be at least 2 feet greater than NPSHr. For NPSHr values, refer to the standard performance curve for your pump model or contact Iwaki or Your distributor.
4. When using a bend on the suction side, install a straight pipe which is more than 20 inches long or 10 times as long as the suction port diameter before the suction port of the pump. Use the largest possible radius of curvature for the bend.
5. Do not allow any projection where air may be trapped along the suction pipe. The suction pipe should have an ascending gradient toward the pump.
6. If the diameters of the pump suction port and suction pipe are different, use an eccentric reducer pipe. Connect the eccentric reducer pipe such that the upper part of it is level. **Never use a suction pipe with a diameter smaller than that of the pump's suction port.**
7. When using the flooded suction method, the suction pipe should be given a slight ascending gradient toward the pump so that no air pocket is created on the suction side.
8. The end of the suction pipe should be located 24 inches or more below the surface of the liquid.
9. A screen should be provided at the inlet of the suction tank to prevent the entrance of foreign matter into the suction pipe. Foreign matter may cause malfunctioning of and/or damage to the pump. The end of the suction pipe should be at least 1- 1.5D from the bottom of the suction tank. (D=Diameter of suction pipe).
10. When employing the suction lift method, install a foot valve on the suction pipe.
11. When using the flooded suction method, it is recommended that a gate valve be installed on the suction pipe for easier overhaul inspection of the pump. Since this valve is used only in the overhaul inspection of the pump, keep it fully opened during normal pump operation.

12. Pay close attention to the lowest level of the liquid in the suction tank to avoid vortexing, air entrapment and associated suction piping concerns. The inflow pipe into the suction tank should be distanced from the suction pipe and positioned below the liquid surface as a means of preventing air entrapment to the suction pipe. If air bubbles are generated in the suction tank, install a baffle.
13. It is recommended that a vacuum/pressure gauge be installed on the suction piping approximately 6 pipe diameters from the pump suction port.

Discharge Piping

1. Use proper pipe supports so that the weight of the piping does not load the pump nozzle.
2. If a method other than flooded suction is used, install a special pipe for priming.
3. If the piping is very long, its diameter should be determined by calculating the piping resistance. Otherwise, the specified performance may not be obtained due to increased piping resistance.
4. A check valve should be installed if any of the following conditions exists in the piping:
 - The discharge piping is very long.
 - The discharge head is 50 feet or more.
 - The end of the discharge pipe is located 30 feet higher than the surface of the suction tank.
 - Several pumps are connected in parallel with the same piping.
5. The installation of a gate valve on the discharge pipe is recommended for the adjustment of discharge quantity and for the prevention of motor overload. When installing both a check valve and a gate valve, the check valve should be positioned between the pump and the gate valve.
6. A pressure gauge must be installed on the discharge piping, prior to the gate valve.
7. An air bleeding valve should be installed if the discharge pipe is very long in the horizontal direction.
8. A drain valve should be installed for the drainage of liquid if there is a chance that the liquid in the discharge pipe will freeze.

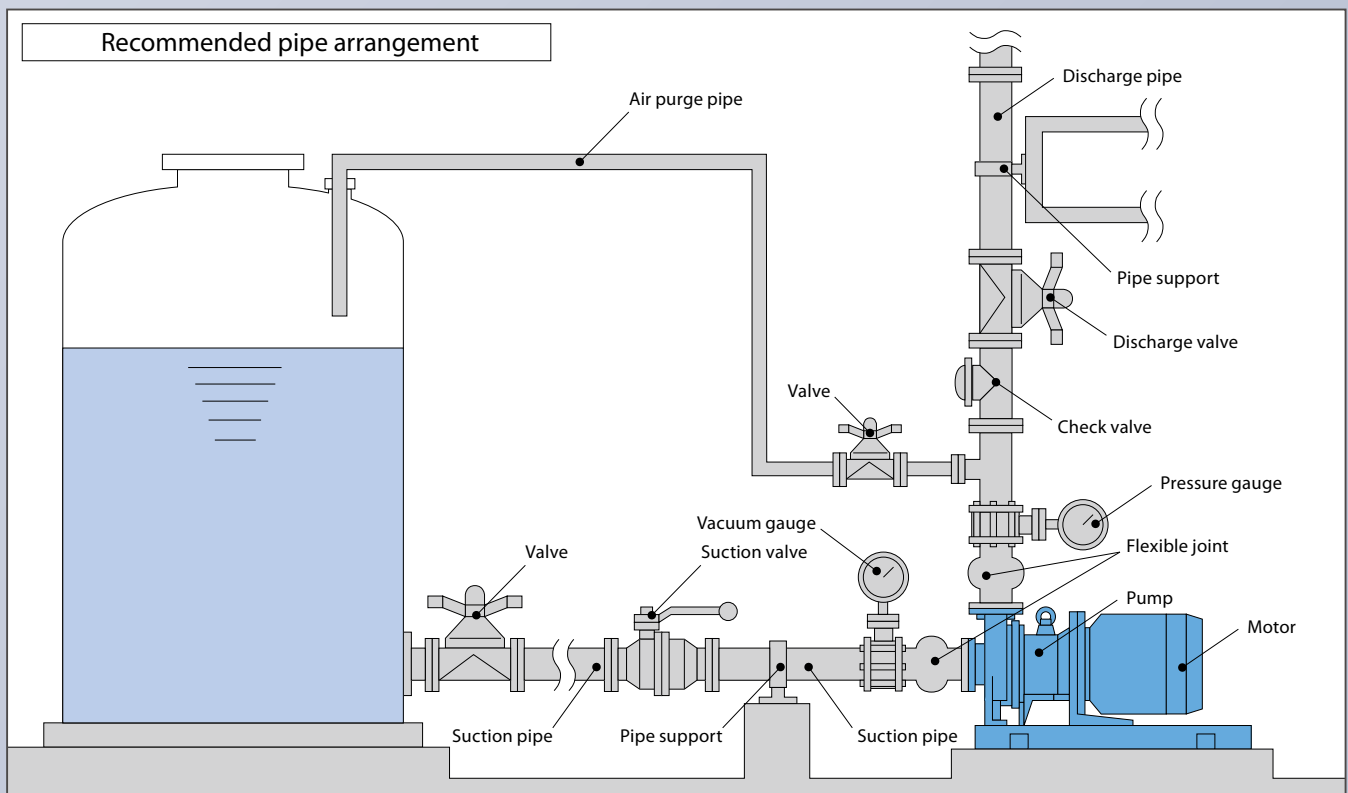

Magnetic Drive Pumps Applications

Pump Control System Examples

Etching system

- Maintains a constant spray pressure by controlling the pump discharge pressure

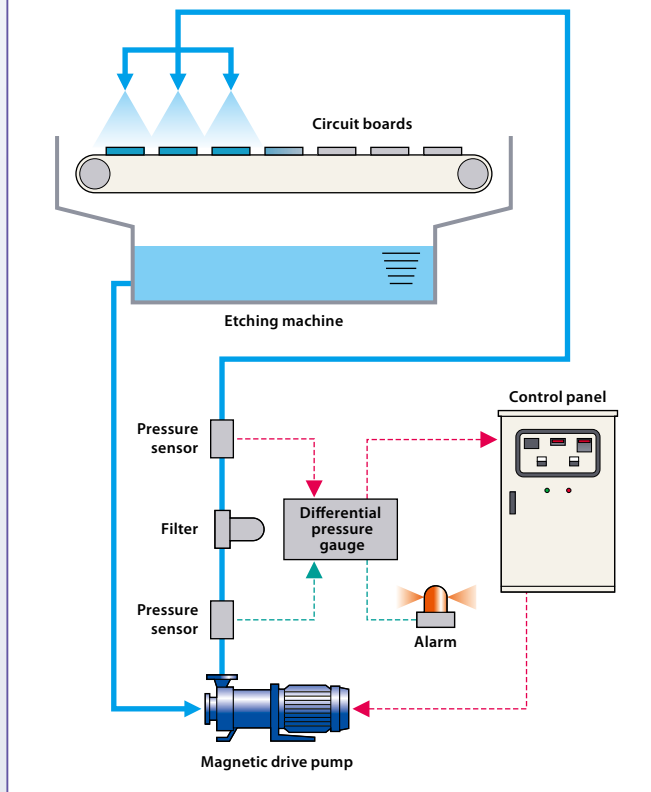

Pressure test/pressure control system

- Serves as a pressure test device for pipes, valves, and containers; controls the water pressure applied to the test target
- Provides fast response time and excellent stability by using PFC to control the pressure

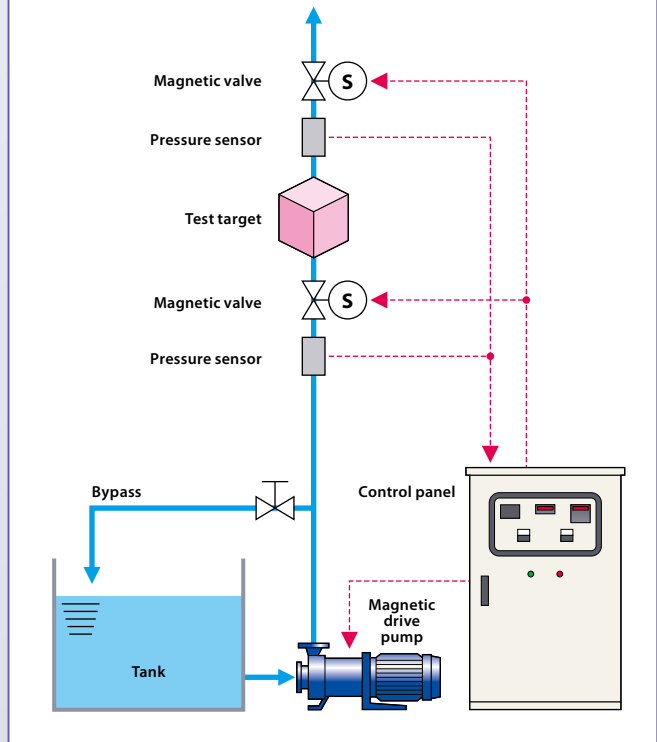

Blending System Examples

System for diluting sulfuric acid

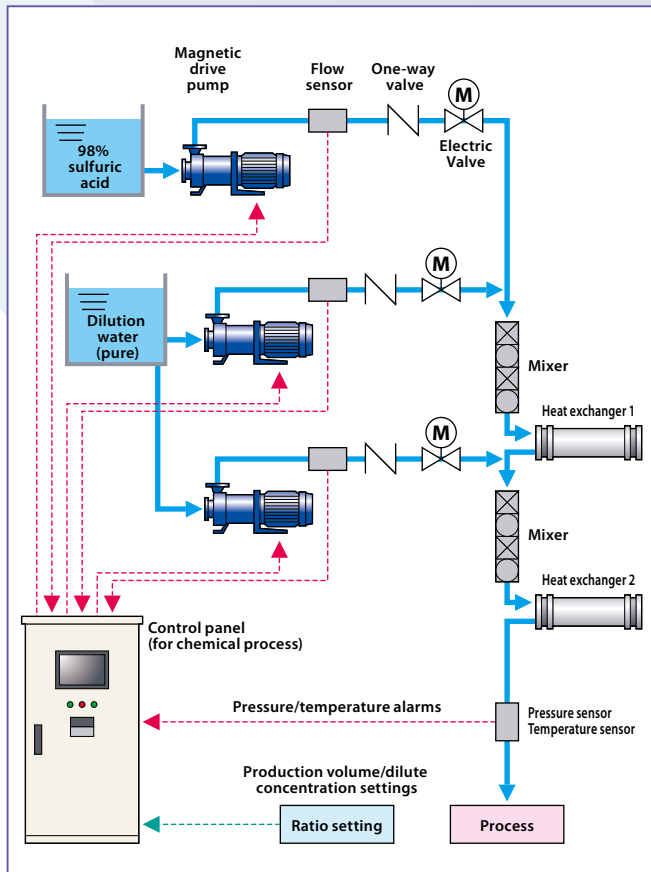

System for diluting sodium hydroxide

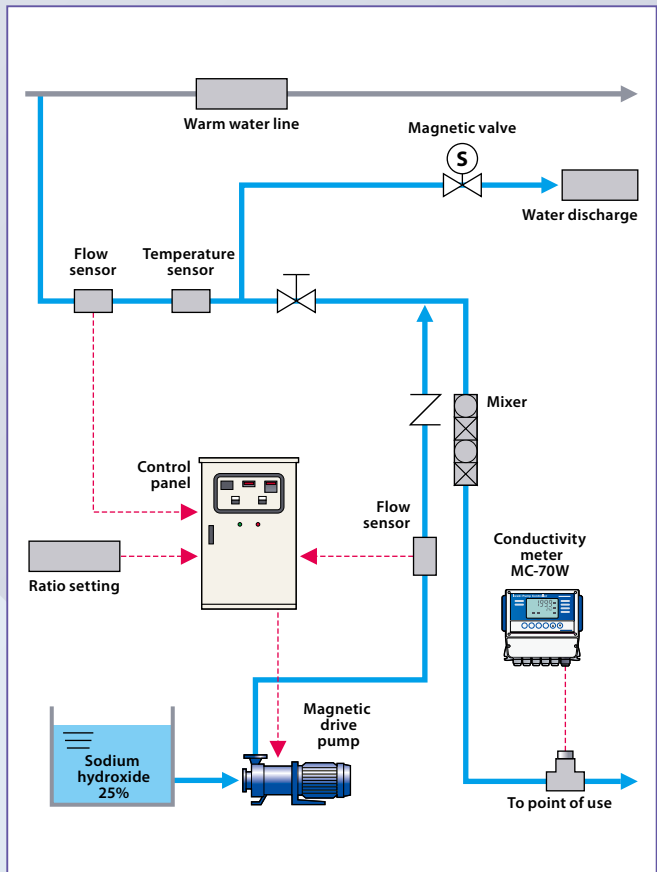

Residual Chlorine Concentration System Examples

System for reducing bacteria in bathtubs and swimming pools

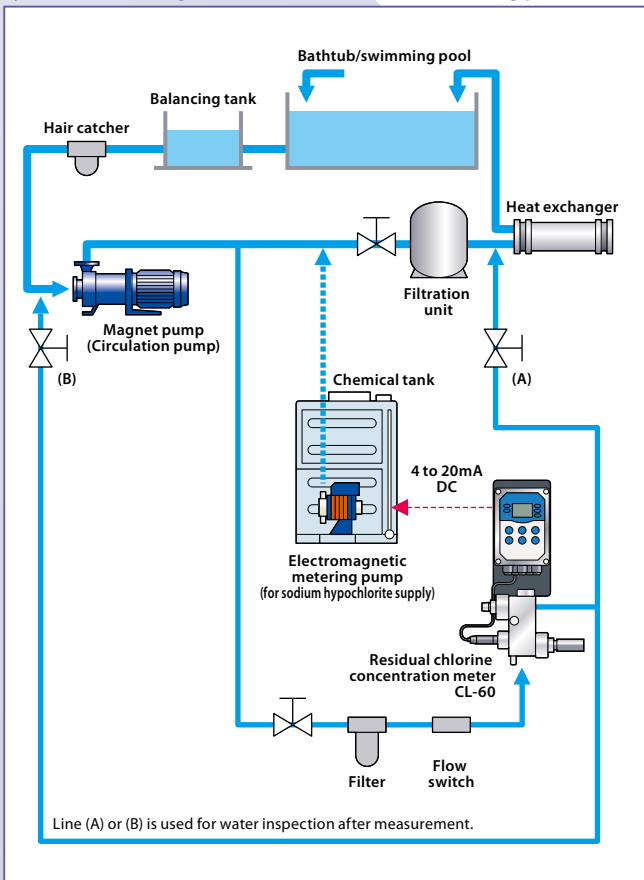

System for reducing bacteria in drinking water

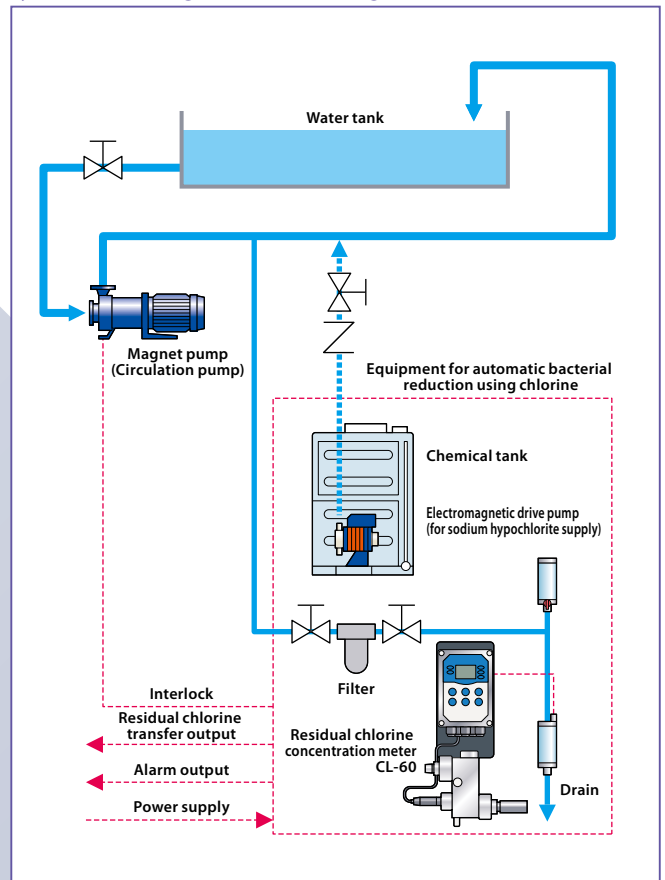

Optional Accessories

DR

• Iwaki dry run protection DR series

The DR series is a dry run protection device that monitors the electric current of the motor. This device will automatically stop the pump when the motor's current draw fall below a set lower limit, runs dry or is overloaded.

- Displays current set value
- Allow upper and lower current control settings
 - Upper limit: Overload
 - Lower limit: Dry running and cavitation
- Built-in current transformer
- DIN rail mounting



DR-10

Model	DR-10, DR-20		DR-11, DR-21	
Motor power	200 to 240V 3-phase	380 to 440V 3-phase	200 to 240V 3-phase	380 to 440V 3-phase
Applied motor	0.4 to 7.5kW	0.75 to 15kW	11 to 37kW	18.5 to 75kW
Control power	100V to 240V single-phase			
Power	DR-10/11: 100V ±10% single-phase, DR-20/21: 200 to 240V ±10% single-phase			
	Input	3.5W		
Detective current	0.5 to 32A		20 to 200A	
Current transformer (CT)	Built-in		Separate	
Dimension	D80×W153×H122			

• Motor output depends on the motor specification. A DR and an inverter cannot be used in the same system.



Current transformer (CT)

IWAKI World-wide Network

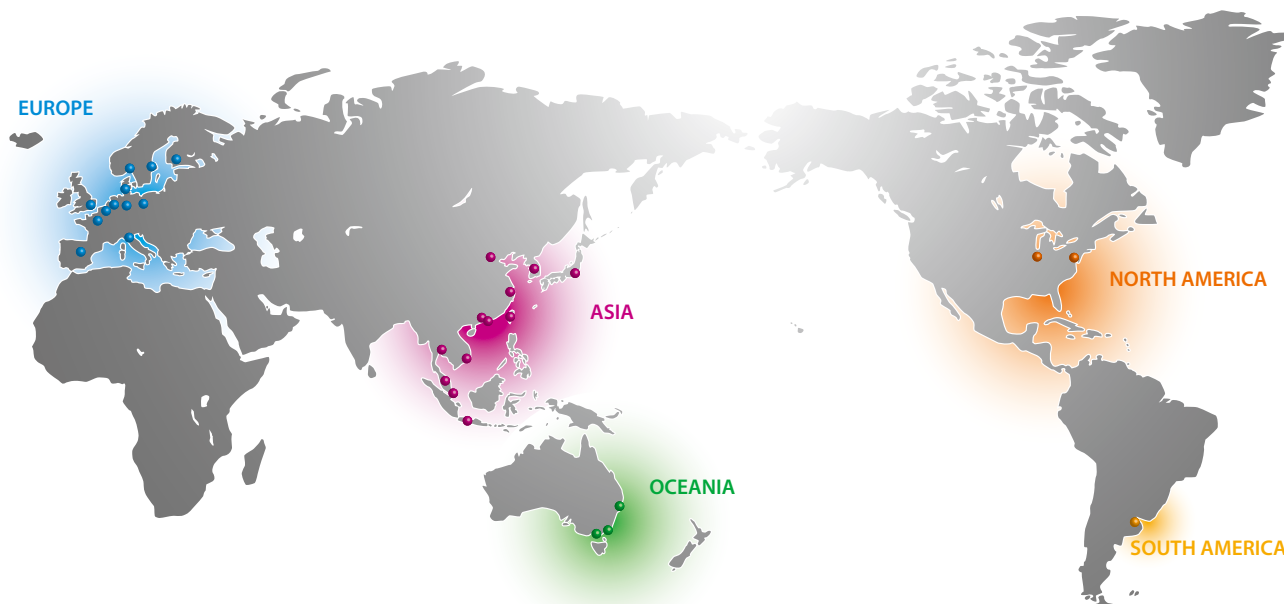

EUROPE

European office	: IWAKI Europe GmbH	TEL: (49)2154 9254 0	FAX: 2154 9254 48
Holland	: IWAKI Europe (NL Branch)	TEL: (31)547 293 160	FAX: 547 292 332
Belgium	: IWAKI Belgium N.V.	TEL: (32)13 67 02 00	FAX: 13 67 20 30
Denmark	: IWAKI Nordic A/S	TEL: (45)48 24 2345	FAX: 48 24 2346
Finland	: IWAKI Suomi Oy	TEL: (358)9 2745810	FAX: 9 2742715
France	: IWAKI France S.A.	TEL: (33)1 69 63 33 70	FAX: 1 64 49 92 73
Germany	: IWAKI Europe GmbH	TEL: (49)2154 9254 50	FAX: 2154 9254 55
Italy	: IWAKI Italia S.R.L.	TEL: (39)02 990 3931	FAX: 02 990 42888
Norway	: IWAKI Norge AS	TEL: (47)66 81 16 60	FAX: 66 81 16 61
Spain	: IWAKI Iberica Pumps, S.A.	TEL: (34)943 630030	FAX: 943 628799
Sweden	: IWAKI Sverige AB	TEL: (46)8 511 72900	FAX: 8 511 72922
Switzerland	: IWAKI (Schweiz) AG	TEL: (41)26 674 93 00	FAX: 26 674 93 02
U.K.	: IWAKI Pumps (UK) Ltd.	TEL: (44)1743 231363	FAX: 1743 366507

ASIA

China	: IWAKI Pumps Co., Ltd.	TEL: (852)2607 1168	FAX: 2607 1000
Hong Kong	: IWAKI Pumps (Shanghai) Co., Ltd.	TEL: (86)21 6272 7502	FAX: 21 6272 6929
Shanghai	: GFTZ IWAKI Engineering & Trading Co., Ltd.	TEL: (86)20 8435 0603	FAX: 20 8435 9181
Guangzhou	: GFTZ Iwaki Engineering & Trading Co., Ltd. (Beijing office)	TEL: (86)10 6442 7713	FAX: 10 6442 7712
Beijing	: IWAKI Korea Co., Ltd.	TEL: (82)2 2630 4800	FAX: 2 2630 4801
Korea	: IWAKI Singapore Pte Ltd.	TEL: (60)3 7803 8807	FAX: 3 7803 4800
Malaysia	: IWAKI Singapore Pte Ltd.	TEL: (65)6316 2028	FAX: 6316 3221
Singapore	: IWAKI Singapore (Indonesia Branch)	TEL: (62)21 6906606	FAX: 21 6906612
Indonesia	: IWAKI Pumps Taiwan Co., Ltd.	TEL: (886)2 8227 6900	FAX: 2 8227 6818
Taiwan	: IWAKI (Thailand) Co., Ltd.	TEL: (66)2 322 2471	FAX: 2 322 2477
Thailand	: IWAKI Pumps Vietnam Co., Ltd.	TEL: (84)613 933456	FAX: 613 933399
Vietnam			

NORTH AMERICA

U.S.A.	: IWAKI America Inc.	TEL: (1)508 429 1440	FAX: 508 429 1386
--------	----------------------	----------------------	-------------------

OCEANIA

Australia	: IWAKI Pumps Australia Pty Ltd.	TEL: (61)2 9899 2411	FAX: 2 9899 2421
-----------	----------------------------------	----------------------	------------------

SOUTH AMERICA

Argentina	: IWAKI America Inc. (Argentina Branch)	TEL: (54)11 4745 4116
-----------	---	-----------------------

() Country codes



IWAKI Saitama plant



IWAKI Miharu plant



www.iwakipumps.jp

IWAKI CO.,LTD. 6-6 Kanda-Sudacho 2-chome Chiyoda-ku Tokyo 101-8558 Japan TEL : (81)3 3254 2935 FAX : 3 3252 8892



Caution: Before use of pump, read instruction manual carefully.

Actual pumps may differ from the photos. Specifications and dimensions are subject to change without prior notice. For further details please contact Iwaki.



Export License.

Our products and/or parts require export control licenses in some cases. An export license may be required.

