

Magnetic drive pumps

Magnetic drive process pump resistant to dry run damage



Magnetic drive pumps

The MDM Series of Magnetic drive process pumps have wetted parts made of fluororesin.

Patent

JAPAN / U.S.A. / TAIWAN

Pat.Pend.

EU / KOREA / CHINA



Magnetic drive process pump resistant to dry run damage

The MDM Series of Magnetic drive process pumps have wetted parts made of fluororesin. Natural PFA and CFRETFE being standard materials of construction.

The MDM features a unique mechanism which gives a greatly improved performance against dry running (Non contact system). Applications cover a wide range of chemical process duties from acid to alkali together with high purity chemicals for the semiconductor industry.

Unique design prevents dry running

(Non contact system)

The pump design features a mechanism to withstand dry running. High magnet power of the rare earth magnets prevents the magnet capsule coming into contact with the thrust ring of the rear casing, thus preventing melting of fluororesin components due to heat generation. This greatly improves resistance against dry running in comparison with conventional magnetic drive pumps made of fluororesin.

Note: Only CF type (fitted with high density carbon bearing) can cope with dry running. Dry running is not permitted in the case of KK type.

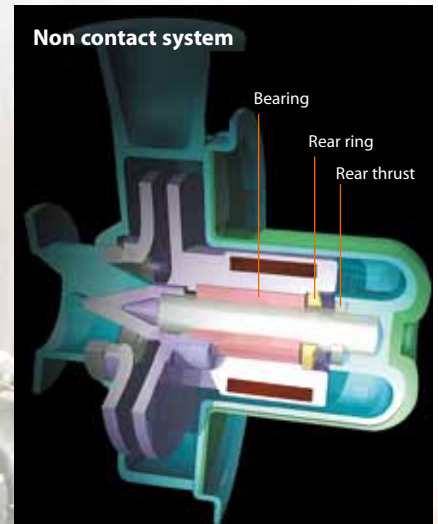

MDM65(ETFE type)

ETFE and PFA available in standard models

Carbon fibre reinforced ETFE (CFRETFE) and PFA linings can be supplied to meet many varying duties. PFA being a natural unfilled material generates fewer contaminants and makes it ideally suited for transfer of high purity chemicals.

Highly durable structure

A ductile cast iron shell adds strength and durability to the outer peripheral surfaces of the fluoro resin pump module. The rear casing which is placed under the highest stress is protected by a rear casing cover made from fibre reinforced plastic. This gives sufficient strength and eliminates the eddy current loss caused by the rotating magnetic field. Should it come into contact with the drive magnet unit, no spark would be generated and a high level of safety would be maintained.

Back pullout system

In order to facilitate inspection and maintenance, this series employs the back pullout system. This enables one to conduct inspections internally and replace parts without removing piping. The pump is designed to include safety measures that can prevent the liquid from leaking when the foot support is pulled back.

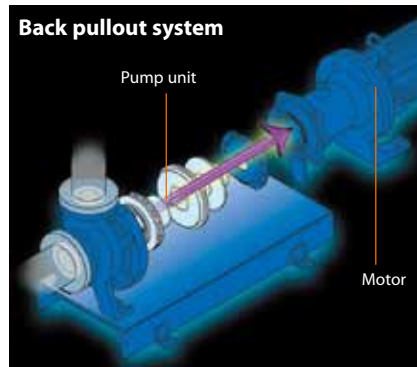

Now available high head models

High head models MDM25-3 and MDM40-2 now join MDM Series which is favoured as fluoro plastic made process magnet drive pump. The models obtain 74 meters head (50Hz), 107 meters head (60Hz) to expand the application.

Compliance with JIS standards

The pump with a common base comply with JIS Standards in regard to piping connection.

Note 1: For compatibility in size with other series of our magnet pumps, please call us.

Note 2: ANSI and ISO standards are also available.

For details, please call us.

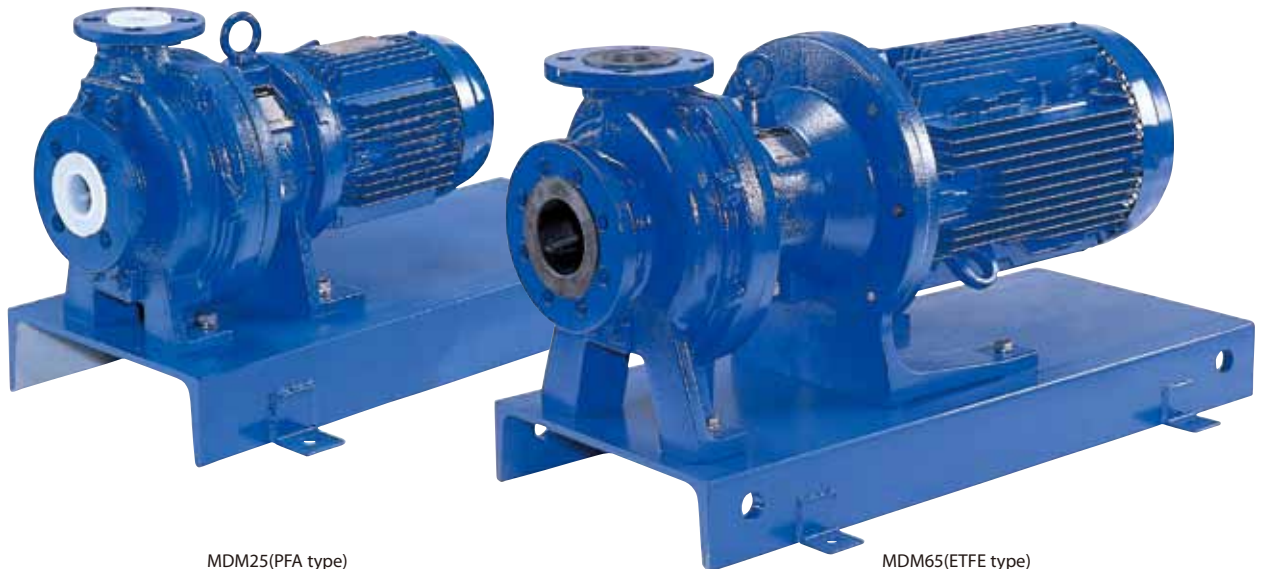

MDM25(PFA type)

MDM65(ETFE type)

Construction

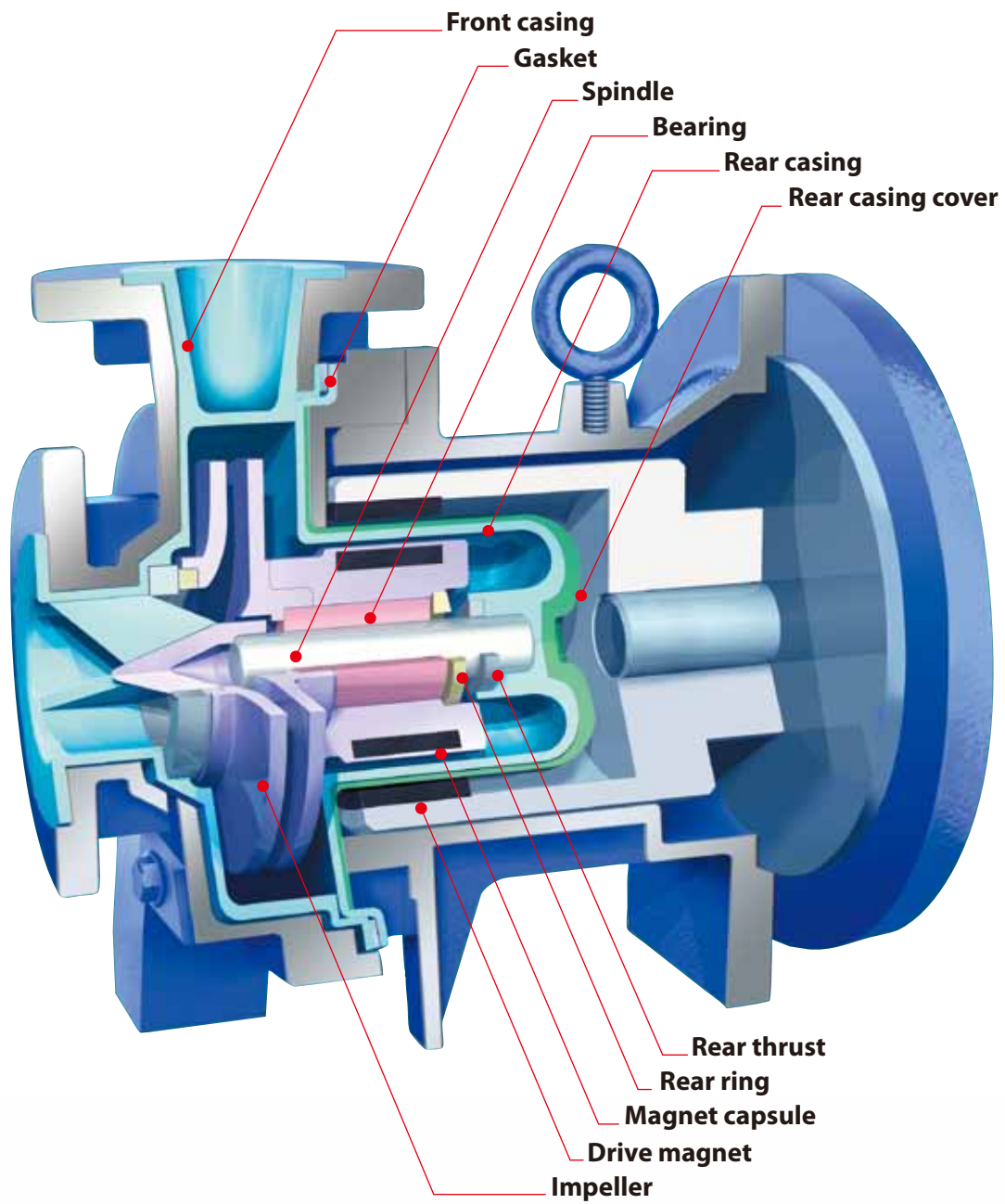

Wet-end materials

| | Materials | ECF | EKK | PCK |
|----|-------------------------------------|-----------------------------|--------------------|------|
| 1 | Front casing | CFRETFE | SiC | PFA |
| 2 | Rear casing <small>(Note 1)</small> | | | |
| 3 | Impeller | | | |
| 4 | Magnet capsule | High density carbon | SiC | SiC |
| 5 | Bearing | | | |
| 6 | Spindle | | | |
| 7 | Liner ring | | | |
| 8 | Mouth ring | PTFE (with filler) | PTFE (with filler) | PTFE |
| 9 | Rear ring | High purity alumina ceramic | | |
| 10 | Rear thrust | PTFE (with filler) | | |
| 11 | Gasket | PTFE | | |

Note1: Rear casing of MDM25-3 and MDM40-2 for over 80°C application is special construction (Patent pending).

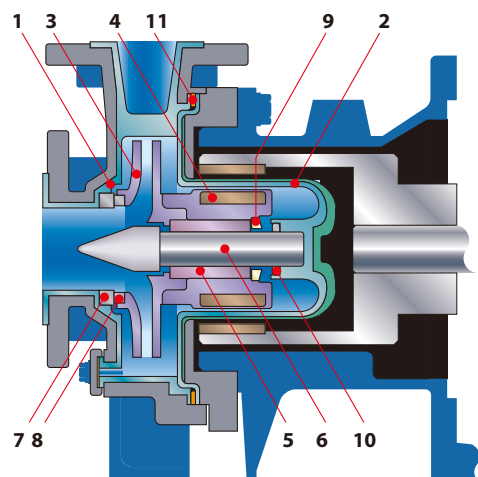

Front casing ETFE type

A moulding made of carbon fibre reinforced ETFE (CFRETFE). It has both a high mechanical strength and excellent corrosion resistance. The outer peripheral surfaces are reinforced by a ductile cast iron outer casing in order to achieve excellent strength and durability.



ETFE type

Front casing PFA type

The ductile cast iron casing is a one-piece moulding with natural PFA fluoro-resin lining integrally moulded. This construction is free from contamination and ideal for transfer of clean liquids or with less particle generation.



PFA type

Note: For lower duty MDM25 type a different moulding method is used.

Impeller

Closed type impellers are designed to give high efficiency. To ensure positive fixing of impeller to magnet capsule a spline system together with a pin fixing is employed. This prevents the impeller from moving axially off the magnet capsule (PAT.PEND.). MDM25 and 40 models now have impellers capable of reaching max. heads of 74 meters (50Hz), 107 meters (60Hz) to widen the range of application.



ETFE type



PFA type

Rear casing

Rear casing cover

The fluoro-resin rear casing is strengthened by the outer rear casing cover which is manufactured in fibre reinforced plastic capable of withstanding a pressure of 1 MPa. This structure also eliminates any eddy current losses due to a rotating magnetic field. It also prevents sparks from being produced should the rear casing come into contact with the drive magnet unit. A newly developed triple-layer casing (PAT. PEND) is used for the high head models MDM25-3 and 40-2 when liquid temperature exceeds 80°C. This new design allows a rated 1.6MPa casing pressure overall temperature range. Since the front and rear casing are bolted together from the front casing side, liquid does not leak out when the foot support is pulled back.



PFA type with rear casing cover

Rear ring

As a precaution against abnormal running, for example cavitation or air entering the pump where the magnet capsule could move axially backwards a rear ring and thrust ring have been incorporated. The rear ring is designed to give minimal heat generation from contact and therefore heat generation is greatly reduced compared to conventional designs. This prevents surrounding fluoro-resin from melting. (PAT.PEND.)

Rear Thrust

The rear thrust withstands axial loads encountered from abnormal operation, it also minimizes heat generation.

Magnet capsule

High magnet strength rare earth magnets are totally encapsulated with fluoro-resin mouldings. Magnets are small and lightweight which increases the efficiency of the pump. Taking advantage of the high magnetic strength its new design of "Non contact system" was developed to protect pump from dry running. This enables us to offer pumps that will withstand dry running operation. (CF type only)



ETFE type



PFA type

Spindle

Both ends of the spindle are supported by the front casing and the rear casing (the fixed spindle type). There are two types of spindle; one is made of high purity alumina ceramic and the other made of SiC.



SiC type

High purity alumina ceramic type

Bearing

Two standard bearing materials are available. SiC gives high resistance to abrasion. High density carbon withstands dry running operation. Bearings can be individually replaced.



SiC type

High density carbon type

Gasket

A PTFE shrouded gasket is used to enhance sealing performance and corrosion resistance.

Specifications

2 pole motor type

| Model | Pump size Suction X Discharge | 50Hz | | | 60Hz | | | Motor kW |
|--------------------------------------|----------------------------------|---------------|----------------|--------|---------------|----------------|--------|--|
| | | Impeller size | Capacity L/min | Head m | Impeller size | Capacity L/min | Head m | |
| MDM25-1 (Impeller range 1) | 40A X 25A | 165 | 100 | 35.5 | 140 | 100 | 36.0 | 1.5 or 2.2 |
| | | 160 | | 33.5 | 130 | | 29.5 | |
| | | 150 | | 29.0 | 120 | | 24.5 | |
| | | 140 | | 25.0 | 110 | | 20.0 | |
| | | 130 | | 20.5 | 100 | | 15.5 | |
| | | 195 | | 50.5 | 170 | | 53.0 | |
| MDM25-2 (Impeller range 2) | 40A X 25A | 190 | 100 | 47.5 | 160 | 100 | 47.0 | 3.7, 5.5 or 7.5 |
| | | 180 | | 42.5 | 150 | | 40.5 | |
| | | 170 | | 37.0 | 140 | | 35.0 | |
| | | 160 | | 32.5 | 130 | | 29.0 | |
| | | 225 | | 74.0 | 225 | | 107.0 | |
| | | 220 | | 69.0 | 220 | | 102.5 | |
| MDM25-3 (Impeller range 3) | 40A X 25A | 210 | 100 | 61.0 | 210 | 100 | 90.0 | 5.5, 7.5, 11, 15 or 18.5 (60Hz only) |
| | | 200 | | 55.0 | 200 | | 80.0 | |
| | | 190 | | 48.5 | 190 | | 71.0 | |
| | | 180 | | 42.5 | 180 | | 62.5 | |
| | | — | | — | 170 | | 55.0 | |
| | | — | | — | 160 | | 48.0 | |
| | | 165 | | 35.0 | 145 | | 38.0 | |
| | | 160 | | 32.5 | 140 | | 34.5 | |
| MDM40-1 (Impeller range 1) | 50A X 40A | 150 | 208 | 28.5 | 130 | 250 | 29.0 | 3.7, 5.5 or 7.5 |
| | | 140 | | 25.0 | 120 | | 24.0 | |
| | | 130 | | 20.5 | 110 | | 19.5 | |
| | | 120 | | 17.0 | — | | — | |
| | | 225 | | 70.0 | 225 | | 102.0 | |
| | | 220 | | 67.5 | 220 | | 98.0 | |
| MDM40-2 (Impeller range 2) | 50A X 40A | 210 | 208 | 60.0 | 210 | 250 | 87.0 | 5.5, 7.5, 11, 15 or 18.5 (60Hz only) |
| | | 200 | | 54.0 | 200 | | 78.0 | |
| | | 190 | | 47.0 | 190 | | 68.0 | |
| | | 180 | | 41.5 | 180 | | 60.5 | |
| | | 170 | | 38.0 | 170 | | 53.0 | |
| | | 160 | | 32.0 | 160 | | 45.0 | |
| | | 165 | | 33.0 | 160 | | 44.5 | |
| | | 160 | | 31.0 | 150 | | 38.0 | |
| MDM50-1 | 65A X 50A | 150 | 417 | 27.0 | 140 | 500 | 33.0 | 3.7, 5.5 or 7.5 |
| | | 140 | | 22.5 | 130 | | 27.0 | |
| | | 130 | | 18.0 | 120 | | 21.5 | |
| | | 120 | | 15.0 | 110 | | 18.5 | |
| | | 110 | | 12.0 | — | | — | |
| | | 165 | | 38.5 | 160 | | 51.0 | |
| | | 160 | | 35.5 | 150 | | 44.5 | |
| MDM65-1 | 80A X 65A | 150 | 833 | 31.0 | 140 | 1000 | 37.0 | 5.5, 7.5, 11, 15 or 18.5 (60Hz only) |
| | | 140 | | 26.5 | 130 | | 31.5 | |
| | | 130 | | 22.0 | 120 | | 26.0 | |
| | | 120 | | 17.5 | 110 | | 20.0 | |
| | | 110 | | 13.5 | — | | — | |

4 pole motor type

| Model | Pump size Suction X Discharge | Impeller size | 50Hz Capacity L/min | Head m | Impeller size | 60Hz Capacity L/min | Head m | Motor kW |
|--------------------------------------|----------------------------------|---------------|------------------------|--------|---------------|------------------------|--------|--------------------|
| MDM25-1 (Impeller range 1) | 40A X 25A | 170 | 50 | 8.5 | 170 | 50 | 12.0 | 0.4, 0.75 |
| MDM25-2 (Impeller range 2) | 40A X 25A | 200 | 50 | 12.0 | 200 | 50 | 18.5 | 1.5, 2.2, 3.7 |
| MDM25-3 (Impeller range 3) | 40A X 25A | 225 | 50 | 17.0 | 225 | 50 | 24.0 | 1.5, 2.2, 3.7, 5.5 |
| MDM40-1 (Impeller range 1) | 50A X 40A | 170 | 200 | 7.5 | 170 | 200 | 11.5 | 1.5, 2.2, 3.7 |
| MDM40-2 (Impeller range 2) | 50A X 40A | 225 | 200 | 15.0 | 225 | 200 | 22.0 | 1.5, 2.2, 3.7, 5.5 |
| MDM50-1 | 65A X 50A | 170 | 300 | 7.0 | 170 | 300 | 11.5 | 1.5, 2.2, 3.7 |
| MDM65-1 | 80A X 65A | 170 | 500 | 8.0 | 170 | 500 | 13.0 | 1.5, 2.2, 3.7, 5.5 |

Common Specifications

- Temperature range of liquid handled ETFE type : -20 to 105°C, PFA type : -20 to 150°C Note 1
- Allowable slurry (KK type only) Please contact us.
- Allowable maximum pressure 1.0 MPa (MDM25-3 and MDM40-2 are 1.6 MPa)
- Standard motor 2 pole, 3-phase, TEFC, out door flange mount type
- Standard color of paint Ultra marine blue RAL5002

Note 1: Please contact us when handling liquid temperature is below 0°C or handling liquid temperature is higher than 120°C with PFA type.

Pump identification

40 - 150 1 E KK F 075 J - D 2 H

- Pump size (Suction X Discharge)**
25: 40A X 25A
40: 50A X 40A
50: 65A X 50A
65: 80A X 65A
- Impeller size**
100mm to 225mm
- Impeller range**
1, 2, 3
- Wet-end main material**
E: CFRETFE
P: PFA
- Material of Bearing / Spindle**
KK: SiC/SiC
CF: High density carbon/
High purity alumina ceramic
- Motor output**
004: 0.4kW(4P) 075: 7.5kW(2P)
007: 0.75kW(4P) 110: 11kW(2P)
015: 1.5kW 150: 15kW(2P)
022: 2.2kW 185: 18.5kW(2P)
037: 3.7kW (60Hz only)
055: 5.5kW
- Type of motor**
F: Flange motor
- Standard for pipe connection and motor**
J: JIS flange + JIS motor
A: ANSI flange + JIS motor
I: ISO flange + IEC motor
- Special code**
H: 80 to 120°C
(Applicable model:
Flange motor type: MDM25-3, MDM40-2 only)
T: 120 to 150°C
- Motor pole**
2: 2 pole
4: 4 pole
- Special version**

| Mark | Drain | Base | Special version |
|------|---------------|--------------|-----------------|
| A | Without drain | With base | Standard |
| S | | | Special |
| D | With drain | With base | Standard |
| X | | | Special |
| B | Without drain | Without base | Standard |
| Y | | | Special |
| E | With drain | Without base | Standard |
| Z | | | Special |

Note: PFA type with drain includes an air vent.

Performance curves

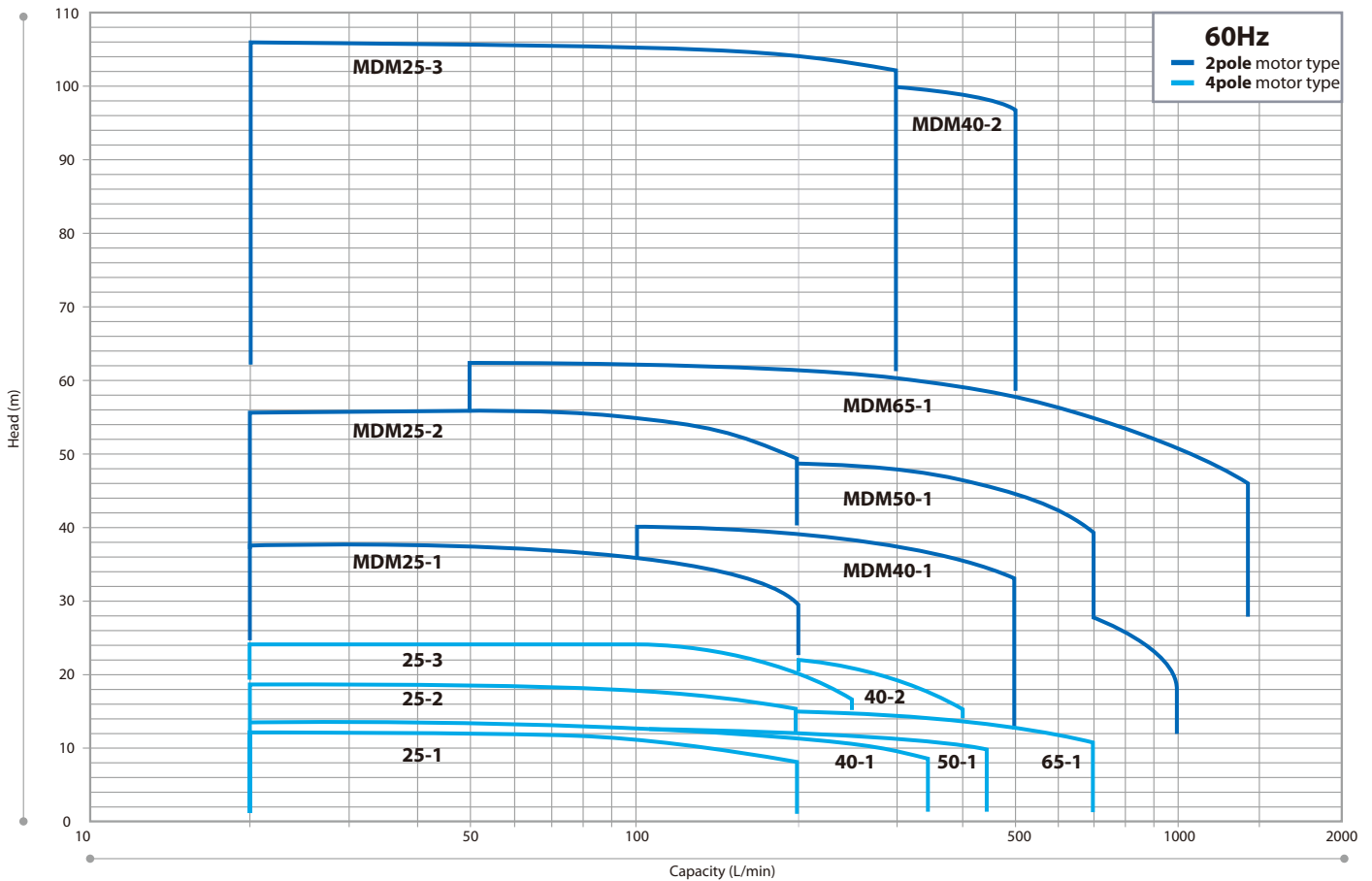
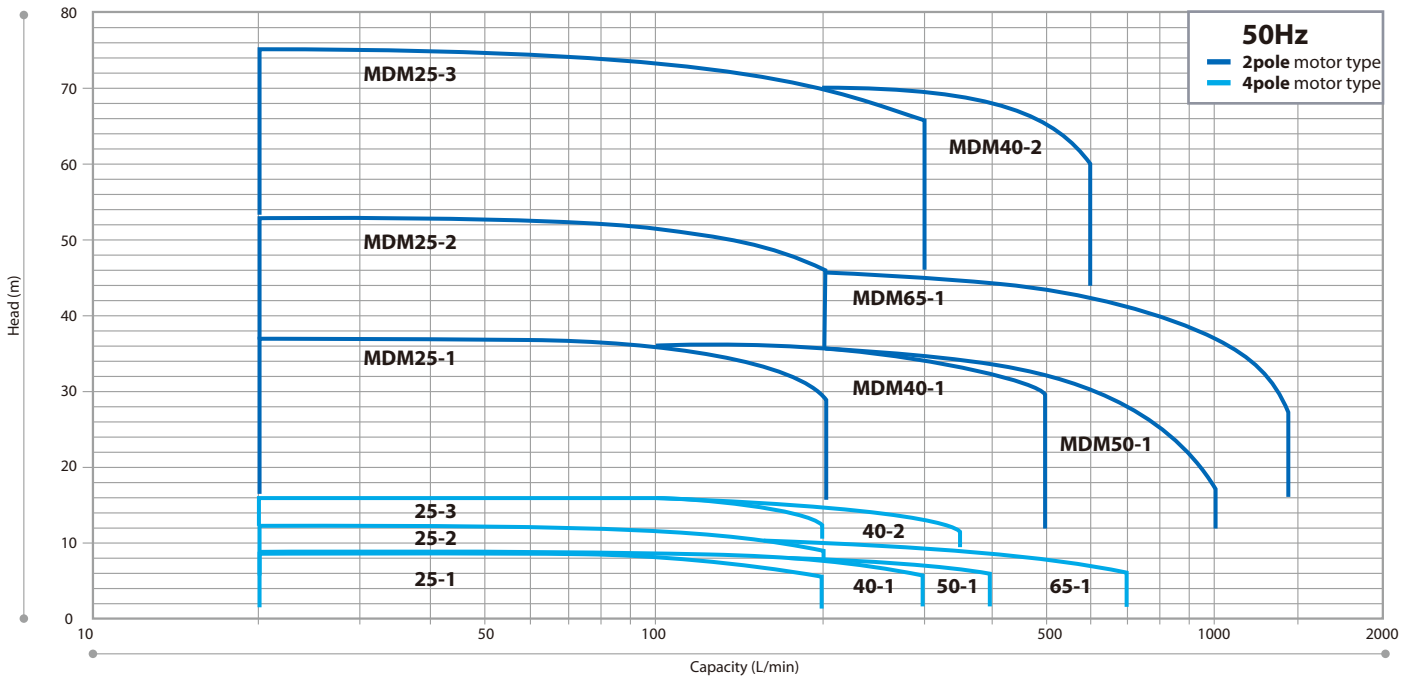

Iwaki dry running protector DR series (Option)

Model DR is electric current sensing type dry running protector. It detects the decreased load current (lower limit) to stop the pump when it runs dry or runs with air sucking in. It can detect over-load, too.



Specification

| | 50/60Hz | |
|-------------------------|--|------------------------------|
| Model | DR-20 | DR-21 |
| Motor power | 380 to 440V | |
| Applied motor | 0.75 to 15kW | 18.5 to 75kW |
| Power | 200 to 240V 10% single phase | |
| 45-65Hz Input | 3.5W | |
| Detective current | 0.5 to 32.0A | 20 to 200A |
| Current transformer(CT) | Built-in | External |
| Current range | Auto | 4.4/17.6/32A |
| | Manual | 2.2/4.4/8.8/11/17.6/26.4/32A |
| Ambient | Temperature:0 to 40°C Humidity:RH40 to 85% | |
| Outer dimension | D80 X W153 X H110 | |

Dimensions

2 pole motor type

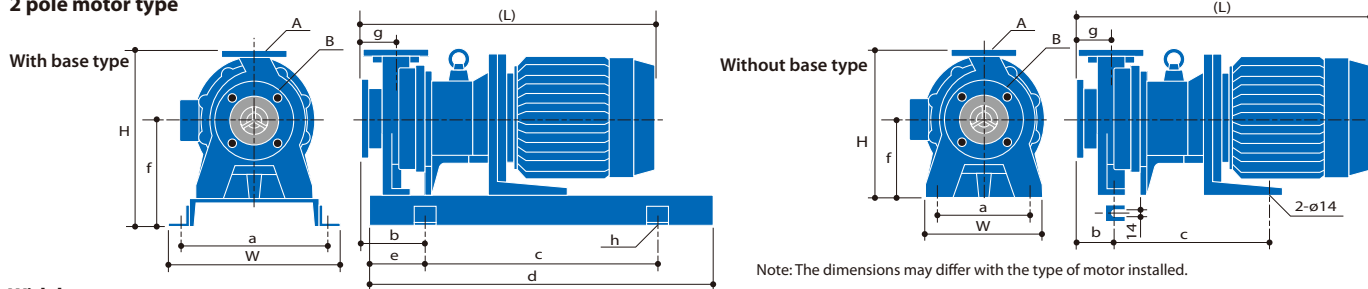

With base type

| Model | Motor | W | H | (L) | a | b | c | (d) | (e) | f | g | h | A | B | Mass kg |
|---------|--------|-----|-----|-----|-----|-----|-----|-----|-----|-----|-----|-------|----|----|---------|
| MDM25-1 | 1.5kW | 400 | 400 | 515 | 350 | 135 | 480 | 710 | 115 | 240 | 80 | 4-ø19 | 25 | 40 | 80 |
| | 2.2kW | | | 625 | | | | | | | | | | | 120 |
| | 3.7kW | | | 689 | | | | | | | | | | | 140 |
| MDM25-2 | 5.5kW | 400 | 430 | 689 | 350 | 150 | 540 | 800 | 130 | 250 | 80 | 4-ø19 | 25 | 40 | 140 |
| | 7.5kW | | | 711 | | | | | | | | | | | 145 |
| | 11kW | | | 864 | | | | | | | | | | | 150 |
| MDM25-3 | 15kW | 480 | 485 | 864 | 430 | 192 | 600 | 900 | 150 | 320 | 102 | 4-ø19 | 25 | 40 | 215 |
| | 18.5kW | | | 886 | | | | | | | | | | | 225 |
| | 3.7kW | | | 625 | | | | | | | | | | | 235 |
| MDM40-1 | 5.5kW | 400 | 410 | 625 | 350 | 150 | 540 | 800 | 130 | 250 | 80 | 4-ø19 | 40 | 50 | 115 |
| | 7.5kW | | | 689 | | | | | | | | | | | 135 |
| | 11kW | | | 842 | | | | | | | | | | | 150 |
| MDM40-2 | 15kW | 480 | 500 | 842 | 430 | 170 | 600 | 900 | 150 | 320 | 80 | 4-ø19 | 40 | 50 | 220 |
| | 18.5kW | | | 864 | | | | | | | | | | | 230 |
| | 3.7kW | | | 625 | | | | | | | | | | | 240 |
| MDM50-1 | 5.5kW | 400 | 410 | 625 | 350 | 150 | 540 | 800 | 130 | 250 | 80 | 4-ø19 | 50 | 65 | 115 |
| | 7.5kW | | | 689 | | | | | | | | | | | 135 |
| | 11kW | | | 862 | | | | | | | | | | | 145 |
| MDM65-1 | 15kW | 480 | 500 | 862 | 430 | 190 | 600 | 900 | 150 | 320 | 100 | 4-ø19 | 65 | 80 | 210 |
| | 18.5kW | | | 884 | | | | | | | | | | | 220 |
| | 5.5kW | | | 709 | | | | | | | | | | | 230 |

Without base type

| Model | Motor | W | H | (L) | a | b | c | f | g | A | B | Mass kg |
|---------|--------|-----|-----|-----|-----|-----|-----|-----|-----|----|----|---------|
| MDM25-1 | 1.5kW | 180 | 310 | 515 | 130 | 100 | 150 | 150 | 80 | 25 | 40 | 55 |
| | 2.2kW | | | 625 | | | | | | | | 95 |
| | 3.7kW | | | 689 | | | | | | | | 110 |
| MDM25-2 | 5.5kW | 280 | 360 | 689 | 220 | 90 | 365 | 180 | 80 | 25 | 40 | 110 |
| | 7.5kW | | | 711 | | | | | | | | 115 |
| | 11kW | | | 864 | | | | | | | | 120 |
| MDM25-3 | 15kW | 280 | 395 | 864 | 220 | 112 | 450 | 230 | 102 | 25 | 40 | 165 |
| | 18.5kW | | | 886 | | | | | | | | 175 |
| | 3.7kW | | | 625 | | | | | | | | 185 |
| MDM40-1 | 5.5kW | 280 | 340 | 625 | 220 | 90 | 285 | 180 | 80 | 40 | 50 | 90 |
| | 7.5kW | | | 689 | | | | | | | | 105 |
| | 11kW | | | 842 | | | | | | | | 120 |
| MDM40-2 | 15kW | 280 | 410 | 842 | 220 | 90 | 450 | 230 | 80 | 40 | 50 | 125 |
| | 18.5kW | | | 864 | | | | | | | | 170 |
| | 3.7kW | | | 625 | | | | | | | | 180 |
| MDM50-1 | 5.5kW | 280 | 340 | 689 | 220 | 90 | 365 | 180 | 80 | 50 | 65 | 105 |
| | 7.5kW | | | 711 | | | | | | | | 120 |
| | 11kW | | | 862 | | | | | | | | 125 |
| MDM65-1 | 15kW | 280 | 410 | 862 | 220 | 110 | 450 | 230 | 100 | 65 | 80 | 170 |
| | 18.5kW | | | 884 | | | | | | | | 175 |
| | 5.5kW | | | 709 | | | | | | | | 185 |

www.iwakipumps.jp

IWAKI CO.,LTD. 6-6 Kanda-Sudacho 2-chome Chiyoda-ku Tokyo 101-8558 Japan TEL : (81)3 3254 2935 FAX : 3 3252 8892

EUROPE / U.S.A.

European office : IWAKI Europe GmbH TEL: (49)2154 9254 0
 Holland : IWAKI Europe (NL Branch) TEL: (31)547 293 160
 Austria : IWAKI (Austria) GmbH TEL: (41)26 674 93 00
 Belgium : IWAKI Belgium N.V. TEL: (32)13 67 02 00
 Denmark : IWAKI Nordic A/S TEL: (45)48 24 2345
 Finland : IWAKI Suomi Oy TEL: (358)9 2745810
 France : IWAKI France S.A. TEL: (33)1 69 63 33 70
 Germany : IWAKI Europe GmbH TEL: (49)2154 9254 50
 Italy : IWAKI Italia S.R.L. TEL: (39)02 990 3931
 Norway : IWAKI Norge AS TEL: (47)66 81 16 60
 Spain : IWAKI Iberica Pumps, S.A. TEL: (34)943 630030
 Sweden : IWAKI Sverige AB TEL: (46)8 511 72900
 Switzerland : IWAKI (Schweiz) AG TEL: (41)26 674 93 00
 U.K. : IWAKI Pumps (UK) Ltd. TEL: (44)1743 231363
 U.S.A. : IWAKI America Inc. TEL: (1)508 429 1440

FAX: 2154 9254 48
 FAX: 547 292 332
 FAX: 26 674 93 02
 FAX: 13 67 20 30
 FAX: 48 24 2346
 FAX: 9 2742715
 FAX: 1 64 49 92 73
 FAX: 2154 9254 55
 FAX: 02 990 42888
 FAX: 66 81 16 61
 FAX: 943 628799
 FAX: 8 511 72922
 FAX: 26 674 93 02
 FAX: 1743 366507
 FAX: 508 429 1386

ASIA / OCEANIA

Australia : IWAKI Pumps Australia Pty Ltd. TEL: (61)2 9899 2411
 China : IWAKI Pumps Co., Ltd. TEL: (852)2607 1168
 Hong Kong : IWAKI Pumps (Shanghai) Co., Ltd. TEL: (86)21 6272 7502
 Shanghai : GFTZ IWAKI Engineering & Trading Co., Ltd. TEL: (86)20 8435 0603
 Guangzhou : GFTZ Iwaki Engineering & Trading Co., Ltd. (Beijing office) TEL: (86)10 6442 7713
 Beijing : IWAKI Korea Co., Ltd. TEL: (82)2 2630 4800
 Korea : IWAKI Sdn. Bhd. TEL: (60)3 7803 8807
 Malaysia : IWAKI Singapore Pte Ltd. TEL: (65)6316 2028
 Singapore : IWAKI Singapore (Indonesia Branch) TEL: (62)21 6906606
 Indonesia : IWAKI Pumps Taiwan Co., Ltd. TEL: (886)2 8227 6900
 Taiwan : IWAKI (Thailand) Co., Ltd. TEL: (66)2 322 2471
 Thailand : IWAKI Pumps Vietnam Co., Ltd. TEL: (84)613 933456
 Vietnam : IWAKI Pumps Vietnam Co., Ltd. TEL: (84)613 933399

FAX : 2 9899 2421
 FAX: 2607 1000
 FAX: 21 6272 6929
 FAX: 20 8435 9181
 FAX: 10 6442 7712
 FAX: 2 2630 4801
 FAX: 3 7803 4800
 FAX: 6316 3221
 FAX: 21 6906612
 FAX: 2 8227 6818
 FAX: 2 322 2477
 FAX: 613 933399

Caution for safety use: Before use of pump, read instruction manual carefully to use the product correctly. Actual pumps may differ from the photos. Specifications and dimensions are subject to change without prior notice. For further details please contact us.

Legal attention related to export. Our products and/or parts of products fall in the category of goods contained in control list of international regime for export control. Please be reminded that export license could be required when products are exported due to export control regulations of countries.

