

IWAKI

Electromagnetic Metering Pump

ES Type

Instruction Manual

 Read this manual before use of product

Thank you for choosing an Iwaki's ES Series pump. This instruction manual deals with the correct installation, operation, maintenance, and troubleshooting procedures for the ES model pump. Please read through it carefully to ensure the optimum performance, safety and service of your pump.



TABLE OF CONTENTS

IMPORTANT INSTRUCTION	-----	1
Safety Section	-----	1
1.0 INTRODUCTION	-----	5
1.1 Welcome	-----	5
1.2 Safety and Caution Notes	-----	5
1.3 Principle of Operation	-----	5
1.4 Specifications	-----	6
2.0 INSTALLTION	-----	7
2.1 Unpacking	-----	7
2.2 Location	-----	7
2.3 Supply Tubing	-----	8
2.4 Discharge Tubing	-----	8
2.5 Electrical	-----	8
3.0 OPERATION	-----	9
3.1 Priming	-----	9
3.2 Adjustment	-----	9
3.3 Calibration	-----	10
4.0 MAINTENANCE	-----	11
4.1 Diaphragm Replacement	-----	11
4.2 Valve Replacement	-----	11
4.3 Tubing	-----	11
5.0 Troubleshooting	-----	12
6.0 Model Code & Exploded View	-----	13
6.1 Model Code	-----	13
6.2 Dimensions	-----	14
6.3 Exploded View	-----	15

Important Instruction

For the Safe and Correct Handling of the Pump

- Read the "Safety Instructions" sections carefully to prevent accidents involving you or other personnel and to avoid damage or loss of other assets. Always follow the instructions and advice found in these sections.
- Observe and abide by the instructions described in this manual. These instructions are very important for protecting pump users from dangerous conditions and situations related with the use of the pump system.
- The symbols relate to the following meanings described below.

 Warning.	Nonobservance or misapplication of the contents of the "Warning" section could lead to a serious accident, including death or injury.
 Caution.	Nonobservance or misapplication of the contents of the "Caution" section could lead to serious physical injury to the user or serious damage to the product.

Types of Symbols



Indicates that "**Warning**" or "**Caution**" must be exercised. Inside this triangle, a concrete and practical image provided as a warning or caution message is depicted.









Indicates a prohibited action or procedure. Inside or near this circle, a concrete and practical image of the activity to be avoided is depicted.











Indicates an important action or procedure, which must be performed or carried out without fail. Failure to follow the instructions herein can lead to malfunction or damage to the pump.

Safety Section

 Warning.	
<ul style="list-style-type: none"> Turn off the power supply Working without disconnecting the power supply cause an electrical shock. Before engaging upon any working procedures involving the pump, make sure to turn the power supply switch off and to stop the pump and other related devices. 	 Electrical Shock
<ul style="list-style-type: none"> Terminate operation When you detect or become aware of a dangerous sign or abnormal condition during operation, terminate the operation immediately and start from the beginning again. 	
<ul style="list-style-type: none"> For specified application only The use of a pump in any application other than those clearly specified may result in injury or damage to the pump. Use the pump strictly in accordance with the pump specifications and application range. 	 Prohibited
<ul style="list-style-type: none"> No remodeling Never remodel a pump. Otherwise, a serious accident may result. IWAKI will not be responsible for any accident or damage of any kind which is caused by the user remodeling the pump without first obtaining permission or instructions from IWAKI. 	 No Remodeling
<ul style="list-style-type: none"> Wear protectors If you touch or come in contact with any type of hazardous chemical liquid, including but not limited to chemicals, you may experience a serious injury. Wear protective gear (protective mask, gloves, etc.) during the pump operation. 	 Wear protective gear
<ul style="list-style-type: none"> Operating site must be free of water and humidity The pump is not designed to be complete water-proof or dust – proof. The use of the pump in places where water splashes or humidity is high may result in an electrical shock or short circuit. 	 Prohibited

Safety Section

 Caution.	
<ul style="list-style-type: none"> Qualified operators only The pump operator and pump operation supervisor must not allow any operators who have little or no knowledge of the pump to run operate the pump. Pump operators must have a sound knowledge of the pump and its operation. 	 Prohibited
<ul style="list-style-type: none"> Specified power only. Do not operate the pump on voltage which is not specified on the nameplate. Failure to do so may result in damage or fire. Only the specified power level is to be applied 	 Prohibited
<ul style="list-style-type: none"> Do not run the pump dry. Do not run the pump dry (without liquid inside the pump). Heat generated as a result of abrasion between elements inside the pump during operation without liquid may damage the inside of the pump. 	 Prohibited
<ul style="list-style-type: none"> Do not wet or dampen If an electric part or wiring gets wet with the liquid spilled over accidentally, a fire or electrical shock may be caused. install the system in a place free from liquid spillage or leakage. 	 Do not wet or dampen
<ul style="list-style-type: none"> Ventilate Poisoning may result during an operation, which involves toxic or odorous liquid. Ventilate the operating site sufficiently. 	 Caution
<ul style="list-style-type: none"> Spill-out accident Protective measures should be taken against any accidental spill-out or leakage of the operating liquid as a result of unexpected damage on the pump or the related piping. 	 Caution
<ul style="list-style-type: none"> Damaged pump Never operate a damaged pump. A damaged pump may cause leakage or electrical shock. 	 Prohibited
<ul style="list-style-type: none"> Do not damage or change power cable Do not scratch, damage, process, or pull the power cable forcibly. An extra lode onto the cable, such as heating the cable or placing something heavy on the cable, may damage the cable and finally cause a fire or an electrical shock. 	 Caution

Safety Section



Caution.

- **Install an earth leakage breaker (option)**

The operation of a pump without using an earth leakage breaker may cause an electrical shock. Please purchase an optional leakage breaker and install in the system.



Electrical Shock

- **Handling of power cable**

Use of a defective or damaged power cable may result in a fire or electrical shock. Handle the power cable carefully.



Electrical Shock

- **Follow the instruction manual**

Replace the consumable part by following the descriptions in the instruction manual. Do not disassemble any part of the pump if the disassembling procedure for the part in question is not included in the instruction manual.



- **Limited operating site and storage**

Do not install or store the pump in the following places :

Places where a flammable gas or material is used or stored.

Places where the ambient temperature is extremely high (40°C or higher) or extremely low (0°C or lower).



Prohibited

- **Disposal of used pump**

Disposal of used or damaged pumps must be done in accordance with the relevant local law and regulations. (Consult a licensed industrial waste products disposing company.)



1.0 Introduction

1.1 Welcome

Thank you for choosing an IWAKI ES Series metering pump. This instruction manual deals with the correct installation, operation, maintenance and troubleshooting procedures for the ES model metering pumps. Please read through it carefully to ensure the optimum performance, safety and service of your pump.

1.2 Safety and Caution Notes

Avoid areas where ambient temperature exceeds 40°C or falls below 0°C, or where the pump or tubing would be exposed to direct sunlight.

Disconnect the pump from electrical power source before performing any maintenance.

When working on or around a metering pump, always wear proper protective clothing and equipment as recommended by the supplier of the liquid being pumped.

Depressurize the discharge tubing before disconnecting the tubing or performing any maintenance on the pump.

1.3 Principle of Operation

The ES series electronic metering pump consists of a pump unit, a drive unit, and a control unit. The drive unit is an electromagnetic solenoid. When the solenoid coil is energized by the control unit the armature shaft moves forward due to the magnetic force of the solenoid. The shaft is attached to a PTFE faced diaphragm which is part of the pump unit. The diaphragm is forced into the pump head cavity decreasing volume and increasing pressure which forces liquid in the pump head out through the discharge check valves. When the solenoid coil is de-energized, a spring returns the armature to its starting position. This action pulls the diaphragm out of the head cavity increasing volume and decreasing pressure. Atmospheric pressure then pushes liquid from the supply tank through the suction check valves to refill the pump head.

1.0 Introduction

1.4 Specifications

Capacity/Pressure Rating

Size	Maximum Output Capacity (L/hr) (ml/min)		Output Per Stroke (ml)	Maximum Pressure MPa	Connection Size Tubing (mm)
B10	2.28	38	0.11	1.0	φ 4 x φ 6
B15	3.9	65	0.18	0.7	φ 4 x φ 6
B20	5.7	95	0.26	0.4	φ 4 x φ 6
B30	12.0	200	0.56	0.2	φ 9 x φ 12

Adjustment Range

Recommended frequency adjustment range 0 to 360 strokes per minute

Materials of Construction

Liquid End Code	Pump Head & Fitting	Diaphragm	Valve Ball	Valve Seat	O-Ring	Gasket
VC	PVC	PTFE (bonded to EPDM)	CE	FKM	FKM	PTFE

CE : Alumina Ceramic EPDM : Ethylene propylene diene monomer
 PTFE : Polytetrafluoroethylene FKM : Fluoroelastmer
 PVC : Polyvinylchloride (translucent)

Electrical

ESB-N3 230 VAC ± 10% 0.3 Amp max. 16 watt avg.
 50 Hz, single phase

Operating Conditions

Ambient temperature 0°C to 40°C
 Relative humidity 35% to 90% non-condensing

2.0 Installation

2.1 Unpacking

Open the shipping carton and inspect contents for damage. If any items are missing or damaged contact your local distributor to arrange for replacement.

2.2 Location

Choose a location for the pump which is clean, dry, close to an electrical outlet, and allows convenient access to frequency control and tubing connections. Avoid areas where ambient temperature exceeds 40°C or falls below 0°C, or where the pump or tubing would be exposed to direct sunlight. Flooded suction (mounting the pump below the level of liquid in the supply tank) is strongly recommended, especially when pumping liquids that readily generate gas bubbles. Sodium hypochlorite and hydrogen peroxide are common examples of such liquids. (See Figure 1.)

If flooded suction mounting is not possible, a shelf adjacent to (but not directly above) the supply tank often works well. (See Figure 2.)

The supply tank or cover can also be used if it has provisions for mounting a pump. (See Figure 3.) In any case, the total suction lift should not exceed (1.0 m).

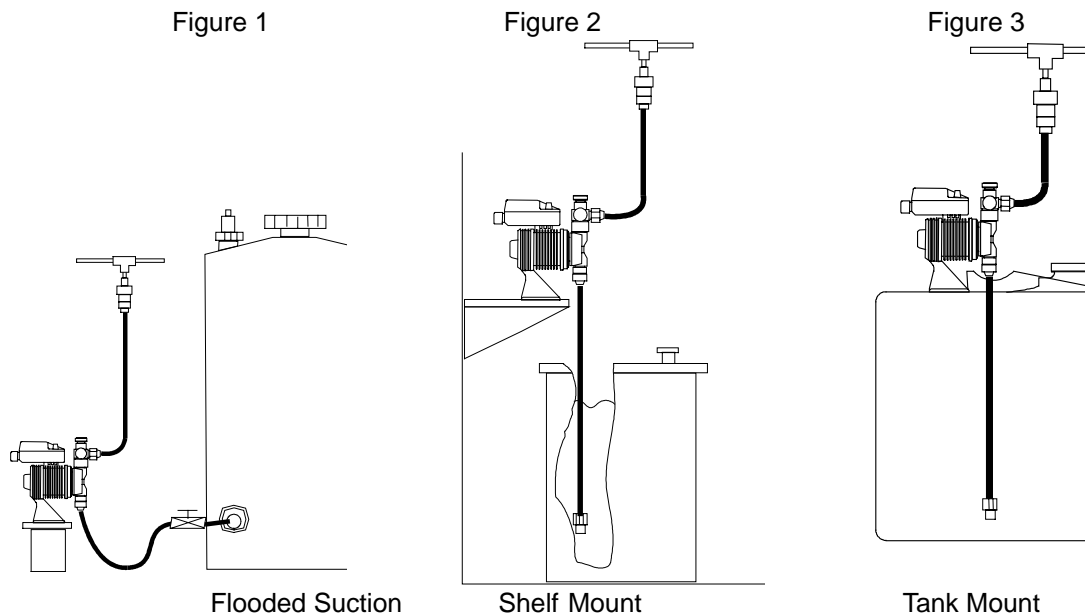

2.0 Installation

2.3 Supply tubing

The supply tubing run should be as short as possible. For flooded suction mounting, install a shut-off valve with an appropriate tubing connector at the tank outlet. Cut a length of tubing from the coil supplied and install between the shut-off valve and the pump inlet fitting. For suction lift applications, install a foot valve on one end of suction tubing and cut the tubing to a length such that the foot valve hangs vertically about 25mm above the bottom of the tank. Avoid any loops in the tubing run that could form a vapor trap. Running the tubing through a length of PVC pipe will help to keep tubing straight.

2.4 Discharge tubing

The discharge tubing run is less critical and can be any length required to reach the application point. Avoid sharp bends or kinks in the tubing and protect the tubing from sharp edges that could chafe or cut it. Install a check valve (optionally available) at the injection point and connect the discharge tubing to the check valve.



Caution.

Any check valve using Hastelloy or other metal springs in liquid end is not usable for chemicals (such as HCL) which corrode the Hastelloy or other metal springs. Ask IWAKI for a special check valve for this application.

2.5 Electrical

Connect the pump power cord to a GROUNDED outlet supplying proper voltage. Avoid branch circuits that also supply power to heavy machinery or other equipment that could generate electrical interference.

3.0 Operation



Caution.

- Do not operate the pump with a completely closed discharge-side valve.
Operating the pump with the discharge-side valve fully closed may lead to liquid leakage or pipe rupture. Make sure not to operate the pump with the discharge-side valve closed.
- Do not run the pump dry.
A pump, which has been run dry, may experience liquid leakage during its liquid feeding operation. Make it a rule to run the pump after supplying liquid inside the pump.
 - * Dry operation of the pump over a long time (longer than 30 minutes) causes the pump to overheat and the pump unit (pump head, valve guide etc.) to become deformed or the pump head attachment to become loose, which may result in liquid leakage trouble.
- Keep the pump head firmly assembled.
If the installation bolts on the pump head are loosened, liquid leakage may result.
 - * Fasten the 4 hex. socket bolts tightly before starting the initial pump operation. (The bolts may be loosened during storage or transportation of the pump, depending upon the condition of each.)
 - * Fastening torque: 2.16 N•m
Tighten all the bolts fully by applying an equal amount of torque in a diagonal order among the bolts.

3.1 Priming

Install the pump as described above. With the pump turned on, set frequency at 100%. If the pump is equipped with an air vent valve, open the knob 1/2 turn. Liquid should move through the suction tubing and into the pump head. When liquid starts running through the vent tubing, close the air vent knob and continue with output adjustment described below. If the pump has no air vent valve, disconnect the discharge tubing from the injection valve. When liquid enters the discharge tubing at the pump head, set frequency to 0% to stop the pump and reconnect the discharge tubing to the injection valve.

3.2 Adjustment

If less than full output is required, set the frequency to the approximate percentage of maximum desired.

3.3 Calibration

If exact output calibration is required, first prime and adjust the pump as above. Then connect a calibration column to the suction side of the pump. Turn the pump on for one minute and read the amount of liquid pumped from the column. Adjust the frequency up or down as necessary and check the output again. When the

desired output is reached, disconnect the calibration column and reconnect the suction tubing. (See Figure 4.)

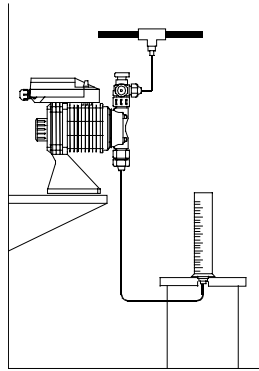

Figure 4
Calibration

4.0 Maintenance

Caution: Before working on the pump, disconnect the power cord, depressurize the discharge tubing and drain or flush any residual liquid for the pump head and valves.

4.1 Diaphragm Replacement

Remove the power cord from the electrical outlet and disconnect the suction tubing, discharge tubing, and air vent tubing. Remove the four head bolts with a 4mm or 5mm hex wrench. Unscrew the diaphragm and remove its retainer (small disk behind the diaphragm). Install the new retainer and diaphragm on the shaft. Turn the diaphragm clockwise until it bottoms on the shaft. Replace the pump head and tighten the head bolts to a torque of 2.16 N-m.

4.2 Valve Replacement

Remove the suction and discharge tubing. Remove the suction fitting, the valve ass'y (consists of 2 x valve ball, 2 x valve seat, 2 x valve guide, 1 x gasket & 1 x o-ring). Install the new valve ass'y. Be sure both valve seats are in the same orientation. Refer to Figure 5, below. Tighten the suction fitting. Similarly remove and replace the discharge valve ass'y.

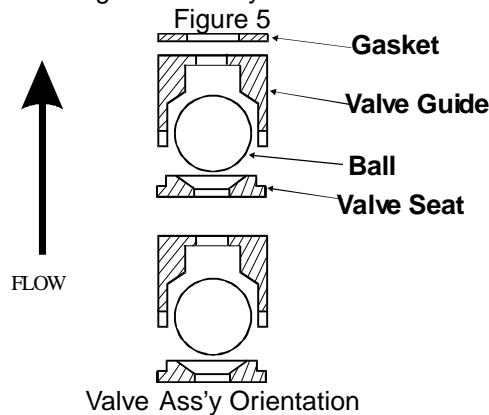

4.3 Tubing

Check ends of tubing for splits, cracks or thin spots. Examine the full length of tubing for damage due to chafing, abrasion, stress cracks, excessive temperature or exposure to ultraviolet light (direct sunlight or mercury vapor lamps). If any signs of deterioration exist, replace the entire length of tubing. It is a good idea to replace discharge tubing on a regular preventive maintenance schedule every 12 months.

5.0 Troubleshooting

Caution: Before Working on the pump disconnect the power cord, depressurize the discharge tubing and drain or flush any residual liquid from the pump head and valves.

Problem	Possible Cause	Corrective Action
Pump does not start	<ul style="list-style-type: none"> - Faulty wiring - Improper voltage - Electronic control unit is damaged 	<ul style="list-style-type: none"> - Correct wiring - Connect to proper voltage source - Replace control unit
Pump does not prime	<ul style="list-style-type: none"> - Air in suction tubing - Valve gasket is not installed - Valve ass'y direction is wrong. - Pump is air locked - Suction or discharge valve is clogged with foreign matter - Adhesion of valve onto valve seat 	<ul style="list-style-type: none"> - Reroute suction tubing to eliminate air trap - Install valve gasket - Reassemble valve ass'y - Open air vent valve - Disassemble, inspect, clean - Disassemble, inspect, clean
Output fluctuates	<ul style="list-style-type: none"> - Suction or discharge valve is clogged with foreign matter - Air is trapped in pump - Overfeeding - Diaphragm is damaged 	<ul style="list-style-type: none"> - Disassemble, inspect, clean - Open air vent valve - Install injection valve or back pressure valve - Replace diaphragm
Liquid leaks	<ul style="list-style-type: none"> - Fitting or coupling nut is loose - Pump head is loose - Diaphragm is damaged - O-ring or valve gasket missing 	<ul style="list-style-type: none"> - Tighten - Tighten pump head bolts - Torque: 2.16 N-m - Replace diaphragm - Install o-ring or valve gasket

6.0 Model Code, Dimensions & Exploded View

6.1 Model Code

ES – B15 VC N – 3

① ② ③ ④ ⑤

① : Pump Series

ES : Electronic metering pump with manual speed control
(adjustable to 360 strokes per minute)

② : Capacity/Pressure Rating

Size	Maximum Output Capacity (L/hr) (ml/min)		Output Per Stroke (ml)	Maximum Pressure MPa	Connection Size Tubing (mm)
B10	2.28	38	0.11	1.0	φ 4 x φ 6
B15	3.9	65	0.18	0.7	φ 4 x φ 6
B20	5.7	95	0.26	0.4	φ 4 x φ 6
B30	12	200	0.56	0.2	φ 9 x φ 12

③ : Liquid End

Liquid End Code	Pump Head & Fitting	Diaphragm	Valve Ball	Valve Seat	O-Ring	Gasket
VC	PVC	PTFE (bonded to EPDM)	CE	FKM	FKM	PTFE

④ : Control Module

N: For all ES-B models with plug, Fixed stroke length only.

⑤ : Voltage

3: 230 VAC, 50 Hz

6.0 Model Code, Dimensions & Exploded View

6.2 Dimensions

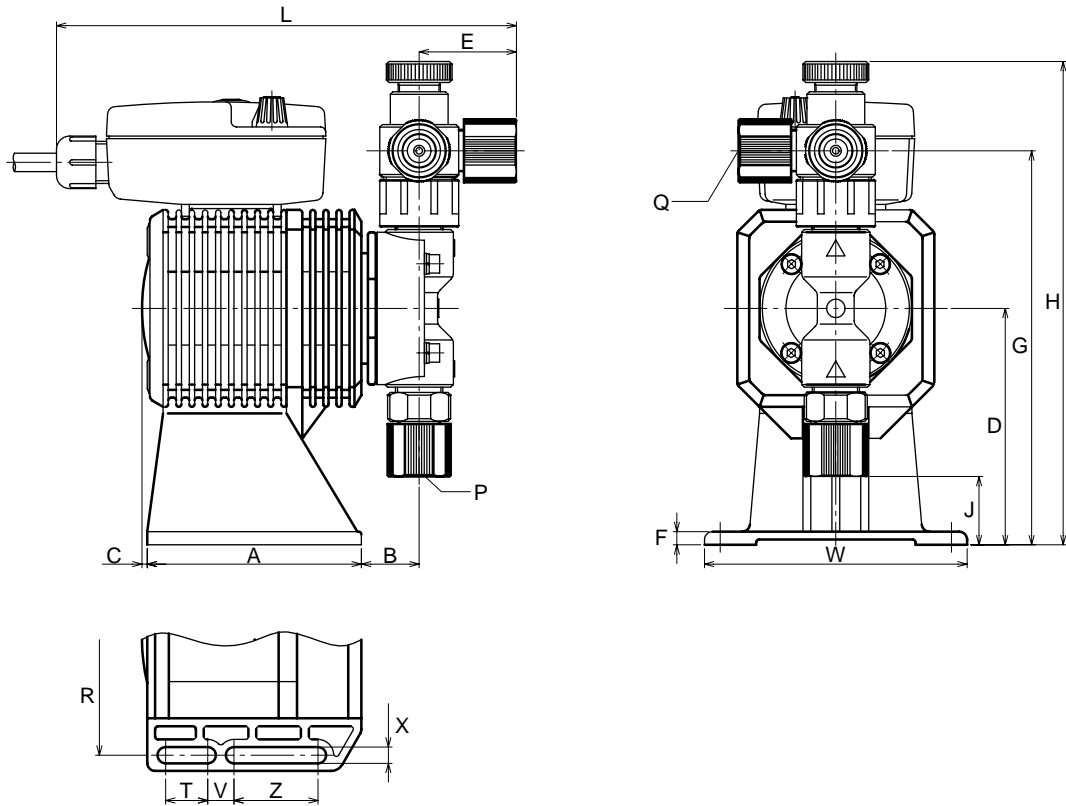

[mm]

Model	A	B	C	D	E	F	G	H	J	L	P&Q Tubing	W
ES-B10VC N-3												
ES-B15VC N-3	81.5	22	2	90	37	5	150	184	28	175	φ 4 x φ 6	100
ES-B20VC N-3												
ES-B30VC N-3	81.5	26	2	90	16	5	-	172	8	158	φ 9 x φ 12	100

Mounting Dimensions	R	T	V	Z	X
ES all variations	88	16	10	32	6.2

6.0 Model Code, Dimensions & Exploded View

6.3 Exploded View (for B-10/15/20)

Models with thermoplastic liquid end materials and air vent valve

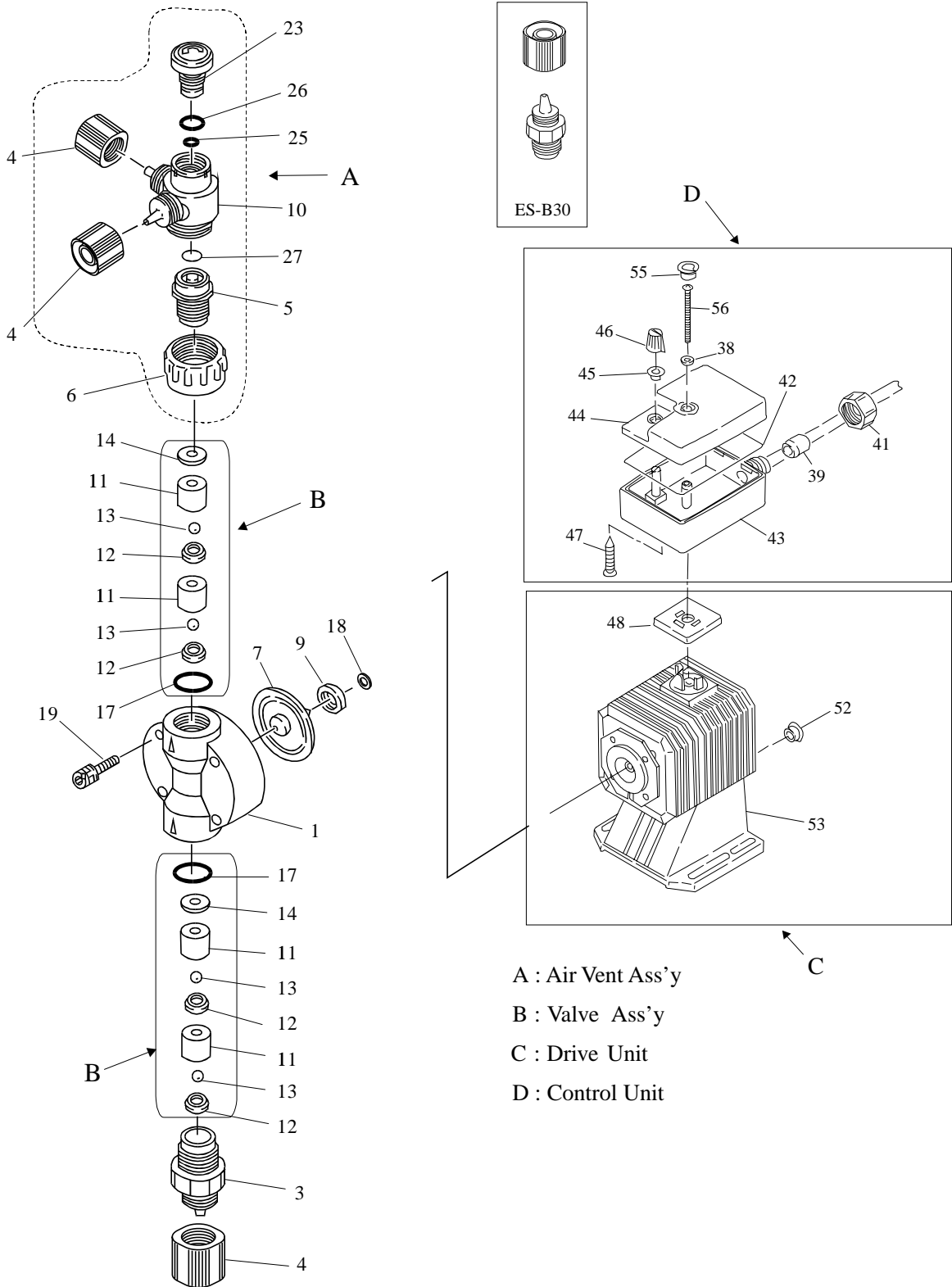

- A : Air Vent Ass'y
- B : Valve Ass'y
- C : Drive Unit
- D : Control Unit

Item	Description	Material	Q'ty per Item			
			B10	B15	B20	B30
1	Head, 10	PVC	1			
1	Head, 15	PVC		1		
1	Head, 20	PVC			1	
1	Head, 30	PVC				1
3	Fitting, ϕ 4 x ϕ 6	PVC	1			
4	Fitting nut, ϕ 4 x ϕ 6	PVC	3			
3	Fitting, ϕ 9 x ϕ 12	PVC				2
4	Fitting nut, ϕ 9 x ϕ 12	PVC				2
5	Air vent body B	PVC	1			
6	Lock nut	PVC	1			
7	Diaphragm, 10	PTFE+EPDM	1			
7	Diaphragm, 15	PTFE+EPDM		1		
7	Diaphragm, 20	PTFE+EPDM			1	
7	Diaphragm, 30	PTFE+EPDM				1
9	Retainer, 10	PPS	1			
9	Retainer, 15	PPS		1		
9	Retainer, 20	PPS			1	
9	Retainer, 30	PPS				1
10	Air vent body A	PVC	1			
11	Valve guide	PVC	4			
12	Valve seat, .	FKM-A	4			
13	Valve ball, .	CE	4			
14	Gasket,	PTFE	2			
17	O-ring, S14	FKM	2			
18	Spacer:0.2,0.3,0.5,0.7mm	Brass	1			
19	Bolt, M4X34	SUS304 equivalent	4			
19	Bolt, M4X36	SUS304 equivalent				4
23	Adjusting Screw	PVC	1			
25	O-ring, P4	FKM-A	1			
26	O-ring, P10A	FKM-A	1			
27	O-ring, P7	FKM-A	1			
38	Gasket	EPDM	1			
39	Cord Gasket E ϕ 6mm	NBR	1			
41	Cord Nut	POM	1			
42	Case Gasket	NBR	1			
43	Control unit case	PPE	1			
44	Control unit cover	PPE	1			
45	SF Gasket	EPDM	1			
46	SF Knob	PE	1			
47	Screw 4x25	SUS304 equivalent	1			
48	Terminal Gasket	NBR	1			
53	Pump body	PPG	1			
52	Plug		1			
55	Cap Gasket	EPDM	1			
56	Screw, M3x35	SUS304 equivalent	1			



IWAKI CO., LTD

6-6 Kanda-sudacho, 2-chome, Chiyoda-ku

Tokyo 101-8558 Japan

Tel: (81) 3 3254 2935 Fax: (81) 3 3252 8892

T324-1 00/6