

IWAKI PUMPS

IWAKI METERING PUMP

AX-SERIES

(LOW-PRESSURE

HYDRAULIC

DIAPHRAGM TYPE)

INSTRUCTION MANUAL

- Unpacking and Inspection (1)
- Principle of Operation (2)
- Identification Codes (3)
- Specifications (Outline) (4)
- Description of Pump Mechanism & Points to Note During Operation (5)
- Installation, Piping, and Wiring (6)
 - Operation (7)
- Maintenance and Inspection (8)
 - Troubleshooting Guide (9)
- Disassembly, Assembly and Adjustment (10)
 - Wear Parts (11)
- Parts Description and Exploded View (12)

Thank you for selecting the Iwaki metering pump AX type. This instruction manual describes the correct handling of the pump, maintenance and inspection procedures, and troubleshooting. You are requested to go through this manual, in order to make maximum use of the pump for a long period of time. After reading it, please keep the manual in a prominent place for ready reference.

Contents

■Item	■Page
① Unpacking and Inspection	1
② Principle of Operation	2
③ Identification Codes	3
④ Specifications (Outline)	6
⑤ Description of Pump Mechanism & Points to Note During Operation	8
⑥ Installation, Piping, and Wiring	11
⑦ Operation	15
⑧ Maintenance and Inspection	20
⑨ Troubleshooting Guide	26
⑩ Disassembly, Assembly and Adjustment	27
⑪ Wear Parts	38
⑫ Parts Description and Exploded View	40

1 Unpacking and Inspection

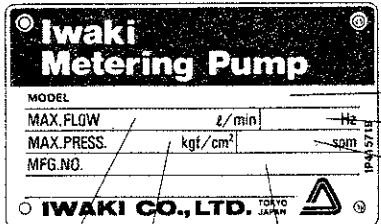

Model
Frequency
Number of strokes

Discharge pressure
Discharge
Manufacturing No.

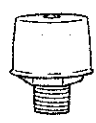

Air breather

After unpacking the pump, check the following points to confirm that the product conforms to your order. If you find anything wrong, please contact the dealer with whom you placed the order.

- ① Do the model, discharge pressure, stroke number, and other details on the nameplate correspond to those of the pump you ordered?
- ② Does the package contain the following accessories?
 - ① Air breathers 2
- ③ Has the pump been damaged, or nuts and bolts been loosened, during delivery?

2

Principle of Operation

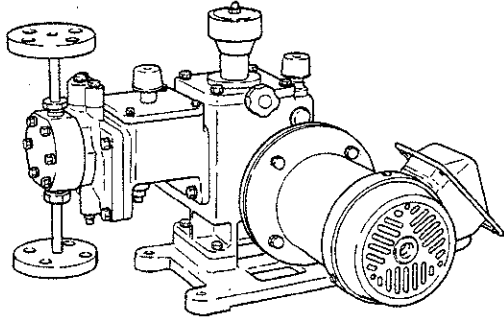

The Iwaki metering pump AX-series is designed for chemical processing. Each pump of this series has a driving unit that employs an SL crank mechanism, a spherical diaphragm, and an oil replenishment valve assembly which operates mechanically.

The decelerating mechanism slows the motor speed, and the SL crank mechanism converts rotation to reciprocating motion, which is transmitted by means of pistons to the diaphragm through hydraulic oil to operate the pump. The discharge is adjusted when a control handle is rotated to change the length of stroke.

3 Identification Codes

Driving Unit	Pump Unit	Motor Unit
┌──────────┐	┌──────────┐	┌──────────┐
2 AXKW	DL 52 S 6 S	04 E F S
① ② ③	④ ⑤ ⑥ ⑦	⑧ ⑨ ⑩ ⑪

Driving Unit	Pump Unit	Motor Unit
┌──────────┐	┌──┐	┌──────────┐
2 AXKW	MT	04 E F S
① ②	※	⑧ ⑨ ⑩ ⑪

① Serial-use model code

Without symbol 1: Single-use pump

2: Dual (or multiple)-use pump (Indicated for models to be used in series of two or more pumps)

② Driving unit model code

Mode	Stroke Length (at 100% stroke)	Standard Motor Output
AXJ	15mm	0.2kW
AXK	24mm	0.4kW
AXA	30mm	0.75kW
AXB	40mm	1.5kW

③ Reduction code

Reduction Code	Reduction Ratio	Stroke Rate (50/60Hz)
G	1/30	48/58spm
W	1/20	72/86spm
H	1/15	96/116spm
R	1/12	120/—spm (50Hz only)

④ Pump head code

Code	Pump Head Type
DL	Low pressure single hydraulic diaphragm
WL	Low pressure double hydraulic diaphragm

⑤ Piston diameter: The figures represent the piston diameter in mm. 7mm is written as 07.

⑥ Material code: For details, see the table of materials in the reference data.

Code	Material of Liquid-Contacting Parts	Remarks
S6	SUS316 or SCS14	SUS types
VH	PVC and HC	PVC types
VS	PVC and SUS316	
VC	PVC and ceramic	
TC	Fluoroplastic	

(Note) HC: Hastelloy C276

⑦ Pump unit made to order

N: For nuclear power (specially controlled, e.g., control on material history)

G: Material approved for use with high-pressure gas

S: Non-standard material

Special valves

Attached with a diaphragm rupture detector

Other special specifications of the pump unit and the hydraulic unit

⑧ Motor output

Code	Output
02	0.2kW
04	0.4kW
07	0.75kW
15	1.5kW
22	2.2kW

⑨ Stroke length adjustment

Code	Stroke Adjusting Method
Without code	Manual
E	Electric servo
A	Air servo (with A-A positioner)
D	Air servo (with E-A positioner)

⑩ RPM control

Code	RPM Control
Without symbol	Fixed rpm
V	VS motor
F	Inverter motor

⑪ Motor unit made to order

S: Special base

Pulse generator

Other special specifications of the driving unit and motor unit

※ Code for multiple connection of different types of pumps

W-MT	Connected pumps have the same driving unit but different types of pump heads.
-MT	Driving units have different reduction ratios.

- When pumps with different types of driving units are connected, one which has the largest output is indicated in ②.

4 Specifications (Outline)

■ Standard specifications (Single type)

Model	Piston Diameter	Stroke Length	Discharge ℓ/min (at spm)						Maximum discharge pressure MPa {kgf/cm ² }	Standard Motor Kw	
			50Hz Stroke rate spm				60Hz Stroke rate spm				
			G:48	W:72	H:96	R:120	G:58	W:86			H:116
AXJ-	7	0~15	0.022	0.034	0.045	0.056	0.027	0.040	0.054	1.0 {10}	0.2
	11		0.061	0.092	0.123	0.153	0.073	0.110	0.147		
	15		0.118	0.177	0.236	0.295	0.142	0.212	0.283		
	22		0.254	0.381	0.508	0.636	0.305	0.458	0.610		
	30		0.478	0.717	0.956	1.19	0.574	0.860	1.14		
	42		0.918	1.37	1.83	2.29	1.10	1.66	2.21	0.7 {7}	
AXK-	30	0~24	0.741	1.11	1.48	1.85	0.892	1.34	1.78	1.0 {10}	0.4/0.2
	42		1.45	2.18	2.90	3.63	1.75	2.62	3.50		
	52		2.25	3.37	4.50	5.62	2.71	4.07	5.42	0.7 {7}	
	68		3.89	5.83	7.73	9.73	4.68	7.03	9.38	0.4 {4}	
AXA-	42	0~30	1.83	2.75	3.67	4.59	2.21	3.32	4.42	1.0 {10}	0.75/0.4
	52		2.81	4.22	5.63	7.03	3.39	5.09	6.78		
	68		4.81	7.21	9.62	12.0	5.79	8.70	11.6	0.7~0.8 {7~8}	
	85		7.52	11.2	15.0	18.8	9.05	13.6	18.1	0.4~0.5 {4~5}	
	100		10.5	15.7	21.0	26.3	12.6	19.0	25.3	0.3 {3}	
AXB-	52	0~40	3.75	5.62	7.50	9.38	4.51	6.78	9.04	1.0 {10}	2.2/1.5/ 0.75
	68		6.41	9.62	12.8	16.0	7.72	11.6	15.4		
	85		10.0	15.0	20.0	25.0	12.0	18.1	24.1		
	100		13.7	20.5	27.4	34.3	16.5	24.8	33.0	0.7 {7}	
	122		20.6	30.9	41.3	51.6	24.8	37.3	49.7	0.5 {5}	

Notes: The maximum discharge pressures are of the stainless type.
 For further details, please refer to the separate "Materials for IWAKI Metering Pump AX Series Selection."

■ Common Specifications

1. Materials of Liquid-Contacting Parts

Material code	SUS Type			PVC Type			Fluororesin
	S6			VH	VS	VC	TC
Classification	AXJ-07~30	AXJ-42 AXK-30~42	AXK-52 or above	AXK-42 or below	AXK-52 or above	Common	
Pump head	SUS316	SCS14		PVC			Fluororesin
Ball valve	HC		SUS316	HC	SUS316	Ceramics	
Valve seat	SUS316			PVC			Fluororesin
Gasket	PTFE			-			-
O ring	-			EPDM		FKM	
Diaphragm	PTFE						

SUS316 : Stainless steel

SCS14 : Stainless steel casting (equivalent to SUS316)

HC : Hastelloy C276

PVC : Hard vinyl chloride

PTFE : Ethylene tetrafluoride resin

EPDM : Ethylene-propylene rubber

FKM : Fluororubber

2. Temperature range of liquid: SUS Type: 0~100°C

PVC Type: 0~50°C

3. Ambient temperature: 0~40°C

4. Standard coating color: Munsell 2.5BG 4.5/6 (excluding motor, which is in manufacturer's standard color)

5. Motor:

Standard: Flange type (IEC Standard)

Others: Various lateral types (common base directly connectable via couplings)

※ Please note that for betterment, sizes are subject to change without notice.

5 Description of Pump Mechanism & Points to Note During Operation

■ Description of Pump Mechanism

① Deceleration mechanism

The motor speed is reduced by a worm and a worm wheel. The standard reduction ratios are 1:30, 1:20, 1:15, and 1:12 (for 50Hz only).

② SL crank mechanism

The SL crank is a mechanism designed to adjust the stroke length. It consists of an eccentric disc of the same eccentricity, SL crank, and coupling disc.

Principle of SL crank mechanism

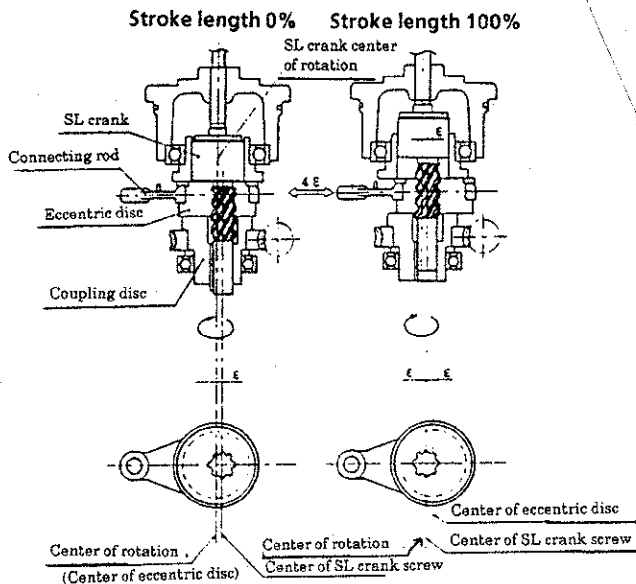

- When stroke length is set at 100% (SL crank is pulled up)
When the SL crank is pulled up, the eccentric disc starts rotation via the SL crank screw. At this moment, the eccentric disc is shifted from the center of SL crank rotation, resulting in a stroke length that is double the eccentricity degree. (The example shows that the eccentric disc has rotated 180° and the eccentricity degree is 2ϵ .)
- When stroke length is set at 0% (SL crank is pushed down)
The center of the eccentric disc is aligned with the center of SL crank rotation. The eccentricity degree ϵ of the SL crank against the center of eccentric disc rotation is offset to result in an eccentricity degree of 0.

③ Stroke length control

To set, increase or decrease the discharge rate, the length of stroke is changed, which is carried out by rotating the control handle of the pump.

④ Diaphragm

The diaphragm is spherical in configuration. It is not stretched when operated. Instead, it only flexes to provide the pumping action.

A spherical diaphragm (Iwaki's original) is used. It is reciprocated correspondingly to changes in configuration of the material (spherical form). This prevents tensile stress from applying to the diaphragm and helps to extend its life compared to the conventional case.

⑤ Oil-feeding selector valve

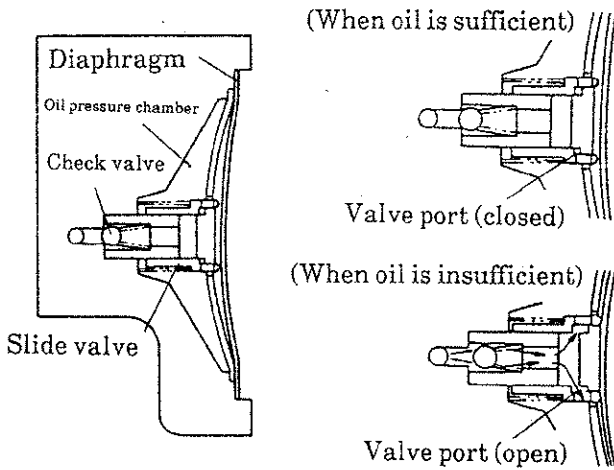

The oil-feeding selector valve unit consists of a slide valve and a check valve. When the oil is insufficient, it operates and feeds oil automatically to the oil pressure chamber, keeping the oil constantly at the required level. The diaphragm pushes the slide valve to open the valve port through which oil flows in.

⑥ Automatic air vent valve

For the prevention of air lock, this valve functions to automatically expel air produced in the hydraulic oil while the pump is in operation so as to maintain metering precision.

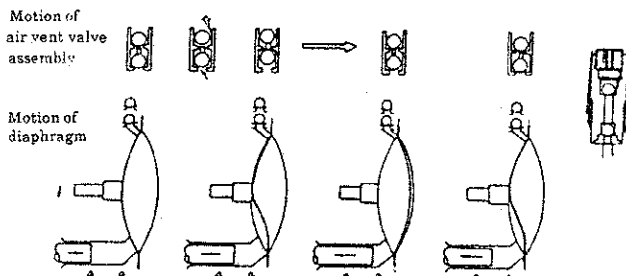

This valve assembly comprises two-layer ball valves provided with upper and lower sealed surfaces. In brief moments during a discharge stroke, when the ball valves move from the lower sealed surface to the upper one, air remaining in the oil pressure chamber is discharged together with a very small amount of oil.

⑦ Air breathers

They control pressure fluctuation in spaces in the driving unit and hydraulic unit. If plugs are not changed to air breathers in supplying oil, air cannot be expelled and an appropriate amount of oil cannot be let in. (See "Installation," Item 6.)

⑧ Relief valve

This valve is activated when the pressure in the pressure-oil chamber rises above a set level, and prevents damage to the diaphragm and the driving unit and an overload on the motor.

■ Notes on Operation

⑨ Cutoff operation prohibited

Never operate the pump without opening the valves in the piping on both the discharge and the suction sides. Do not throttle or close the valves in the discharge and suction piping while the pump is in operation.

② Influence of change in temperature

Although the performance of the pump is not affected by a change in temperature, the liquid handled changes in viscosity, steam pressure, corrosion resistance, etc., as the temperature varies. Therefore, close attention should be paid to changes in the properties of the liquid handled likely to be caused by thermal variation.

▶ Temperature range of liquid handled by pump: 0~100°C (0~50°C for PVC types)

* For the recommended temperature ranges of chemical liquids, refer to the table of corrosion resistance data. If you have any further questions, please contact the dealer you placed your order with.

▶ Temperature range of atmosphere in which the pump is operated: 0~40°C

③ Effect of viscosity on performance

When an AX hydraulic diaphragm pump transfers a viscous liquid, the discharge tends to decrease slightly compared to clear water. In order to maintain precise metering, try to minimize a change in the viscosity through careful control of the temperature of the liquid. As the viscosity of the liquid rises, NPSHr increases. Accordingly, NPSHa should be set at a sufficiently high level if a viscous liquid is transferred.

④ Handling of slurry

Please note that when a slurry is handled, a precision similar to that for clear water is not expected. A short stroke has to be avoided when a slurry is pumped. Otherwise, the precipitation of mud, etc., causes the valves to malfunction and the transfer of the slurry becomes impossible. It should also be noted that in a slurry transfer, solid contents wear away the diaphragm to reduce its expected life.

6 Installation, Piping, and Wiring

■ Recommended Piping

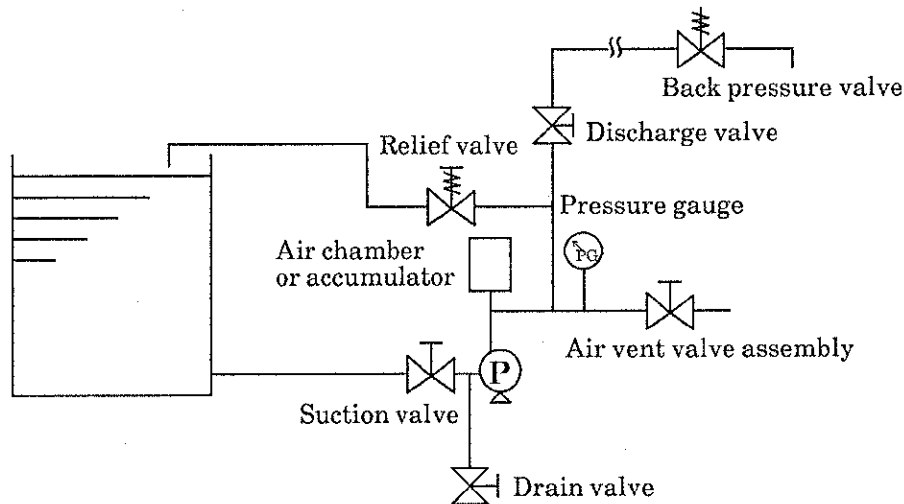

The piping system should be designed to fully meet the requirements for suction and discharge. Well-planned piping is a must particularly when a precipitable slurry is handled.

■ Installation Site

- ① Position the pump as close to the suction side tank as possible, and lower than the lowest liquid surface of the tank. Choose the position that requires the shortest possible length of suction piping.
- ② For ease of maintenance, have enough space around the installation. Take measures to prevent the danger of damage to the motor and power distribution equipment in disasters such as a flood.
- ③ The pump should be installed in a flat place, that is not subjected to the vibrations caused by other machines.

■ Foundation Work

- ① As a concrete floor on soft ground tends to subside or incline, it is necessary to have a space wide enough to bear the weight of the pump and deep enough to prevent the pump from freezing in winter.
- ② For the foundation bolts to be driven into the concrete floor, make holes as marked in the drawing or on the product. Level the floor surface as far as possible. Start installation only after the concrete has set fully.

■ Installation

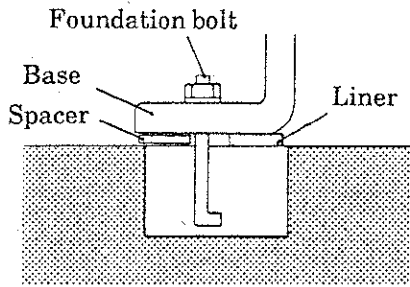

Liner: When the nut is tightened, remove the liner.

- ① After preparing the foundation, position the pump on the concrete.
- ② Insert the liner between the pump base and the concrete foundation to make a gap for mortar grouting. At this time, make sure the liner is inserted evenly (and horizontally) so that the base is not distorted.
- ③ Attach a nut at the head position of the screw of the foundation bolt and leave it hanging down in the hole for the foundation bolt hole in the base.
- ④ Grout mortar into the foundation bolt hole. Leave the mortar for a few days to harden. The surface of the grouted mortar must be at the same level as the surface of the concrete foundation. Use a level to check that the surface is horizontal.
- ⑤ After the mortar has hardened, remove the liner from the base and place a level on the surface of the discharge side flange (or discharge port) to check the levelness again. Next, fasten the nut on the foundation bolt. If it is not level, insert a spacer at the bottom of the base to obtain levelness. Then, fasten the nut to set the pump.
- ⑥ Remove the plugs of the driving units and the hydraulic unit, and mount the air breathers provided (ones with sealing tape wound round them). To mount an air breather, turn its upper hexagonal portion with a wrench.

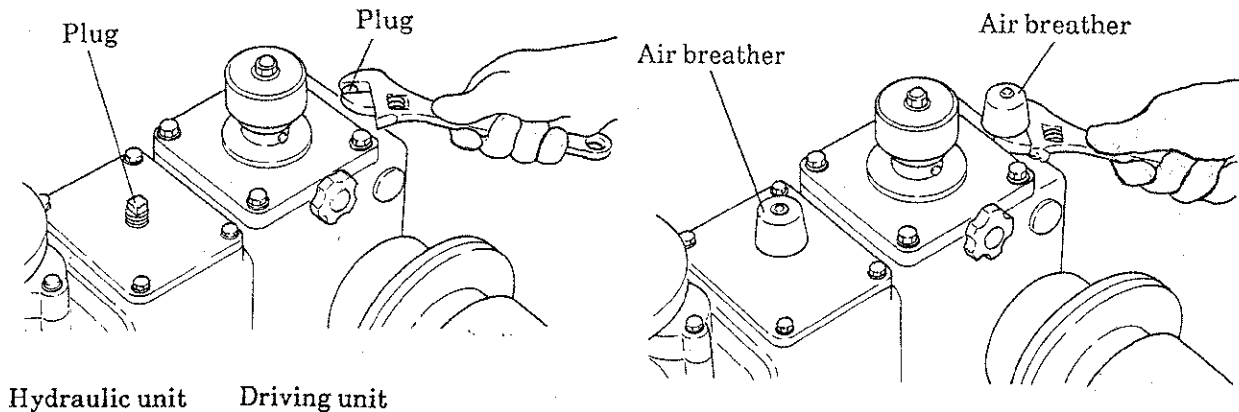

■ Piping (General Matters to be Attended to)

- ① The piping should be as short and with as few bends as possible. Do not make any protrusions, so as to prevent any air from remaining in it.
- ② Provide a support to prevent the piping from applying a load to the pump. Particular care should be taken in this handling in case the liquid-contacting sections are made of PVC.
- ③ If the pump is used to transfer a high or low-temperature liquid, the piping should be designed to protect it from the influence of thermal expansion/contraction.
- ④ If a precipitable slurry is to be transferred, the piping should not have a U-shaped section. It is also necessary to provide a drain plug in the lowermost section of the piping.
- ⑤ If a viscous or toxic liquid, or a liquid likely to stick, is to be transferred, provide piping for flushing to facilitate maintenance and inspection.
- ⑥ When selecting the piping material, take into account corrosion resistance to the liquid to be handled and pressure to be applied to the piping.
- ⑦ Before installing the pipes, clean their insides thoroughly. To prevent foreign matter from entering, blind covers are provided at the inlet and outlet of the pump. Remove them before starting piping work.
- ⑧ If there is a risk of the liquid freezing in the piping, the piping has to be kept warm. To discharge the liquid remaining in the piping, the suction piping should be equipped with a drain cock.
- ⑨ If a PVC pipe is used in the discharge side piping of the pump, care should be taken not to let an adhesive flow into the pump.

■ Suction Piping

- ① The press-in method must be used to install suction-side pipes. Use pipes which are larger in diameter than the pump inlet.
- ② Care must be taken when attaching joints to suction piping, so as not to allow air to be sucked in. If air gets inside the suction piping, the discharge rate will become unstable.

■ Discharge Piping

- ① The pump has a built-in relief valve in the hydraulic chamber. For the protection of the pump, however, make sure to provide a safety valve in the discharge piping, in a position close to the pump. The discharge valve should be attached behind the relief valve.
- ② The discharge piping has to have a pressure above that set for the safety valve. Take special care in fitting joints.
- ③ It is recommended to provide an air chamber as a means to suppress pulsation and to get rid of inertia resistance.
- ④ It is recommended to provide a back pressure valve so as to prevent overfeed as a result of insufficient pressure.
- ⑤ Install a pressure gauge for routine checks of discharge pressure.

■ Wiring

For wiring, use good quality materials and comply with the technical standard for electric installation and the indoor wiring regulations. Strict observance of the following is requested:

Example of Circuit Diagram

power supply

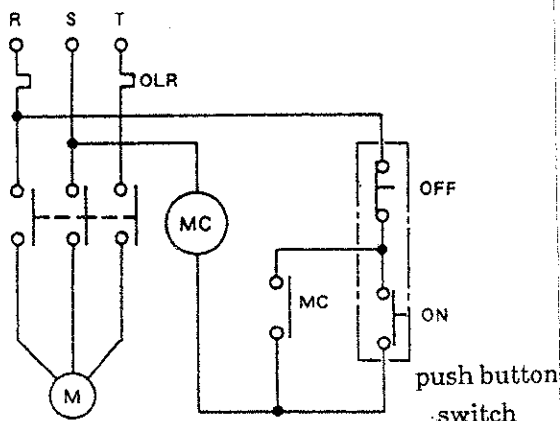

M	motor
MC	electromagnetic switches
ON	push button switches
OFF	push button switches
OLR	Overload relay

- ① Use an electromagnetic switch suitable for the specifications of the motor of the pump.
- ② If the pump is used outdoors, wire it so as not to expose the switches to rainwater, etc.
- ③ The electromagnetic switch and push button switches must be installed securely, in a place away from the pump.
- ④ Wire so that the motor can rotate in the direction indicated by the arrow on the plate (clockwise when viewed from the fan cover side of the motor). When you confirm the direction, make sure to set the stroke at 0% before turning the power switch on.
- ⑤ An ampere meter must be installed to monitor the operation of the pump.

7 Operation

■ Stroke Adjustment

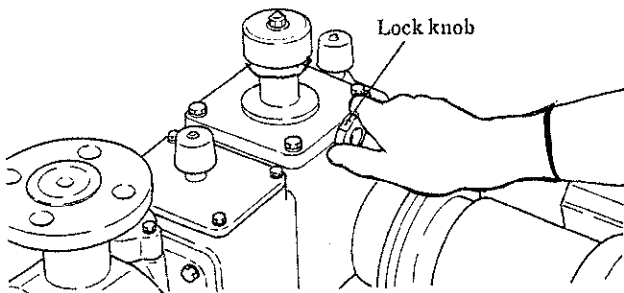
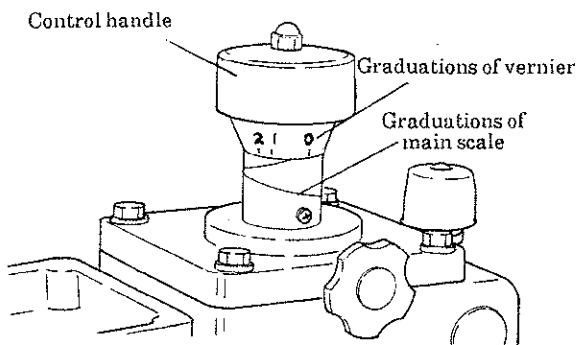

<Manual Operation>

A dial-type control handle is used to adjust the stroke. Adjustment is possible regardless of whether the pump is in or out of operation, but it is preferable to make it while the pump is in operation.

- ▶ Turning to the right (clockwise) decreases the stroke length to reduce the discharge.
- ▶ Turning to the left (counterclockwise) increases the stroke length to raise the discharge.

- ① Select a suitable stroke from the standard performance curve of the pump or the table of test results. The graduations show strokes in %.
- ② Loosen the lock knob. (The control handle is freed.)
- ③ Set the dial at the value of the intended stroke length. The total of the figure on the main scale and the one on the vernier represents stroke length (%).
- ④ After setting the stroke length, tighten the lock knob firmly. Then, try to move the control handle to confirm that it does not move.

<Electric servo or air servo operation>

Please refer to the electric servo/air servo instruction manual.

■ Preparation for Start-Up

During the initial run of the pump after its installation, the following points should be checked.

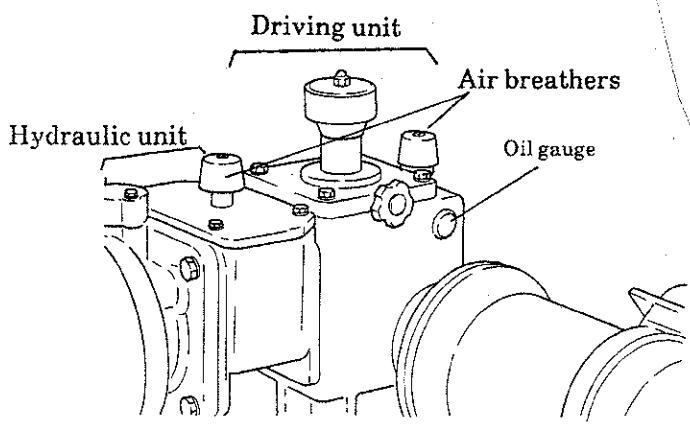

- ◇ Is there any damage, loosened bolt, or oil leakage in the pump?
- ◇ Have the plugs in the driving and hydraulic units been replaced by the air breathers provided? (See "Installation," Item 6.)
- ◇ Confirm by means of the oil gauge in the driving unit that the driving and hydraulic units have the prescribed amounts of oil. (The red label in the middle position of the gauge indicates the prescribed amount.)
- ◇ Make sure that the attachments needed for pump operation, liquid to be handled, and power supply are ready.

■ Operation

Following is the operation procedure of the pump when it is run for the first time after installation.

	Procedure	Points to be Checked/Noted
1	○ Fully open valves in discharge and suction piping.	
2	○ Set stroke at 0%.	
3	○ Turn on power switch of motor, to activate pump.	● Confirm that motor rotates to right (clockwise) when viewed from fan cover side of motor.
4	○ Run pump with stroke at 0% for 10 minutes for break-in. During this period, confirm that everything is in order in all sections of pump.	● In cold weather, overload (amperage above rating) may be observed for a while after start-up. This phenomenon is due to low temperature of oil in pump. If this happens, keep running pump in that no-load condition until oil temperature rises.
5	○ Let air out of pump, as follows. ○ Open drain valve in discharge piping to pour liquid into pump, or increase stroke gradually so as not to apply force.	● In case of AXJ 07, 11 or 15, air should always be vented by pouring liquid into pump.
6	○ Set stroke at 100% while avoiding pressurizing discharge side by making use of, for example, drain valve on discharge piping, and carry out break-in for approx. 10 mins.	
7	○ If everything is found to be in order in break-in, close drain valve gradually and feed liquid to predetermined pipeline.	● In this step, confirm that discharge pressure remains below max. pressure level, that amperage stays within rating, and that there is nothing out of order in all sections of pump. (Refer to the nameplates of pump and motor.)

	Procedure	Points to be Checked/Noted
8	<p>[Checking of discharge]</p> <ul style="list-style-type: none"> ○ If pump has no problem, check discharge under actual working conditions by using a gauge such as measuring cylinder. (Pump is in order if repeatedly measured discharges change little and linearity of discharges to strokes is maintained.) ○ For setting discharge, graph relation between discharges and strokes under actual working conditions. 	<ul style="list-style-type: none"> ● If discharge is increased or decreased by changing stroke, wait for a minute or so before measuring it. ● If requested while placing order for pump, table of pump test results is supplied. Table shows results of tests on clear water at normal temperature (not on actual liquid or through actual piping).

■ Notes on Operation

	Precautions	Remarks
1	<ul style="list-style-type: none"> ○ Do not forget to open valves in piping both on suction and discharge sides before starting up pump. 	
2	<ul style="list-style-type: none"> ○ Take care not to operate with motor rotating in reverse. 	<ul style="list-style-type: none"> ● Confirm that motor rotates clockwise when viewed from fan cover side.
3	<ul style="list-style-type: none"> ○ Since operating pressure of relief valve is set according to specification of product ordered, please refrain from changing it. 	<ul style="list-style-type: none"> ● If substantial change in conditions under which pump is used is planned, please contact us to check whether it is possible.
4	<ul style="list-style-type: none"> ○ In case air chamber is provided Air should be fed regularly to air chamber. For details, see instruction manual of air chamber. 	<ul style="list-style-type: none"> ● Because liquid and air are directly in contact with each other in air chamber, a small amount of compressed air absorbs into the liquid. ● Thus, air keeps decreasing as time goes by, and it becomes difficult for the air chamber to fulfill its functions. To avoid this, air should be supplied at regular intervals.

■ Stoppage of Operation and Restarting

- ◇ When operation is resumed after a brief stoppage (within a week), the pump can be run with any length of stroke.
- ◇ If the pump has been out of operation for a longer period (more than a week), the stroke should be set at 0% and about ten minutes' run in a no-load condition must be carried out. Do not start up the pump immediately for regular operation. Prior to that, an air vent run should be made with gradually increased stroke lengths after the inside of the driving unit is fully lubricated.
- ◇ If the pump is put out of operation in cold weather (even briefly), open the drain piping on the suction side and run the pump without feeding liquid, to get rid of liquid from the piping and the pump chamber. This is to protect the pump from damage likely to be caused by frozen liquid.
In case operation is interrupted temporarily and liquid cannot be drained, the pump should be kept warm by a band heater, etc., to prevent the liquid inside from freezing.

8

Maintenance and Inspection

■ Routine Operation

No.	Checkpoint	Checking Method
1	• Is pump running smoothly?	<ul style="list-style-type: none"> ● By flow meter or visually ● Amperage of motor
2	• Is there any change in discharge or discharge pressure?	<ul style="list-style-type: none"> ● By flow meter, pressure gauge or the like. ● Compare with figures on nameplate
3	• Is there any leakage from liquid-contacting parts?	<ul style="list-style-type: none"> ● Examine sealed sections visually.
4	<ul style="list-style-type: none"> • Does oil in decelerator and hydraulic/driving units run short? • Does oil leak, or is it soiled? 	<ul style="list-style-type: none"> ● By oil gauge ● Visually

■ Periodic Inspection

If there is a spare pump, run it from time to time. It should be serviced so as to be always ready for use.

No.	Item	Remarks
1	<ul style="list-style-type: none"> ● Inspection of discharge and suction valves ▶ Inspect them semiannually. 	<ul style="list-style-type: none"> ● If unusual scratch or abrasion is found in any of them, replace it. ● For replacement, follow instructions in “Disassembly, Reassembly and Adjustment” section.
2	<ul style="list-style-type: none"> ● Inspection of diaphragm ▶ Inspect it semiannually. 	<ul style="list-style-type: none"> ● Diaphragm is an expendable part. Although its life depends on how it is used, it should be checked once every six months and be replaced if deformed. To replace it, follow instructions in “Disassembly, Reassembly and Adjustment” section.

No.	Item	Remarks
3	Oil change in driving and hydraulic units ▶ ① Replacement period: at least once a year ▶ ② Quantity and brand of replacement oil ● Make sure to fill oil up to red label of oil gauge (middle position).	Oil in driving and hydraulic units must be changed more than once a year. In first run which causes initial wear, replace oil when pump is operated for 500 hours. If emulsification or any other harmful phenomenon is observed, replace oil immediately.

● Quantity of Oil to be Changed (for reference)

Model Driving Unit – Piston	Head Size	Quantity of Oil (ℓ)		
AXJ – 07 11 15	D3	1.4		
			D15	1.4
AXK – 22 30	D35	2.2		
			D90	2.7
AXA – 42 52	D90	4.2		
			D170	4.2
100	D250	4.7		
			AXB – 52 68 85	D90
D170	9.7			
		D250		
100 122	D500		11	

The quantities shown in the table are the total amounts of oil in the driving and the hydraulic units, which are interconnected.

● Suitable Oil Brands

Company	Product Name
Idemitsu Kosan	Apolloil ATF D-2
Showa Shell Sekiyu	Gelco ATF
Nihon Sekiyu	Pan ATF Amenity
Mitsubishi Sekiyu	Diamond ATF II
Cosmo Sekiyu	Cosmorio ATX
Esso Sekiyu	Esso ATF
Mobil Sekiyu	Mobil ATF200
Kignus Sekiyu	Burn ATF-K
Kyodo Sekiyu	Kyoseki 21 ATF Special
※Nihon Sun Sekiyu	Sunoco ATF (Note 1)

Iwaki uses the oil marked with ※.

Note 1: Sunoco ATF was formerly called Sunoco Transmatic Fluid DEXRON II-D.

■ Oil Change Procedure

As the driving unit and the hydraulic unit are connected, the oil in both is changed at the same time.

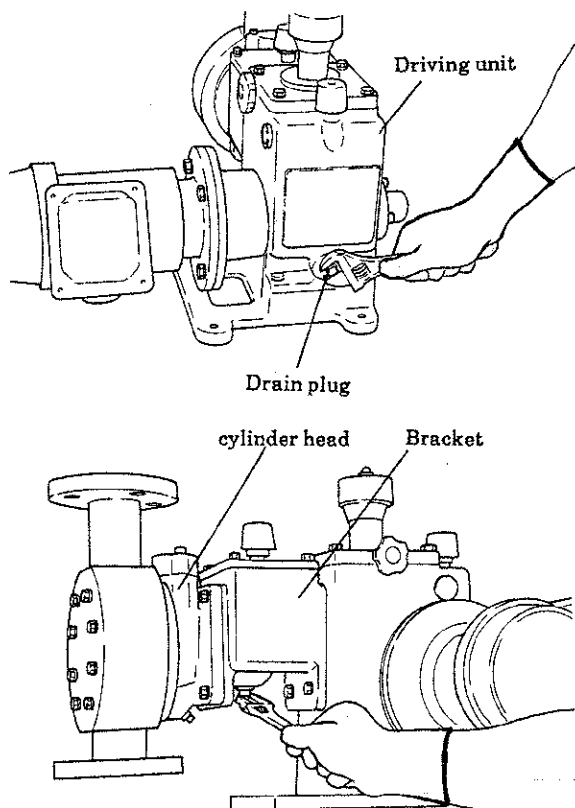

- ① Stop the pump and release it from pressure, for example, by opening the drain valve in the piping.
- ② Remove the drain plugs of the cylinder head, the bracket, and the driving unit and let the oil out.

- ③ Remove the bracket cover and the air vent cover, and remove the relief valve and the air vent valve assembly by means of a wrench. In Model AXA-DL (WL) 100 and AXB-DL (WL) 85~122, remove the oil feed plug and the air vent valve assembly. The relief nut (151) of the relief valve should not be loosened. Remove them as assembled.

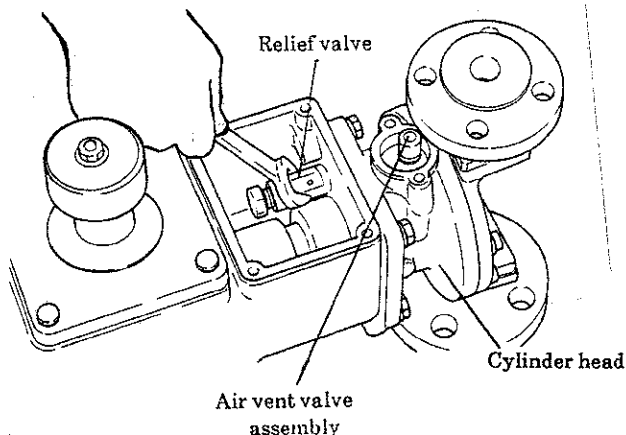

Name	Nominal Size of Wrench
Relief valve (RV-1A)	17
Relief valve (RV-2A)	24
Oil feed plug	17
Air vent valve assembly	13

Model AXA-100 and AXB-85~122

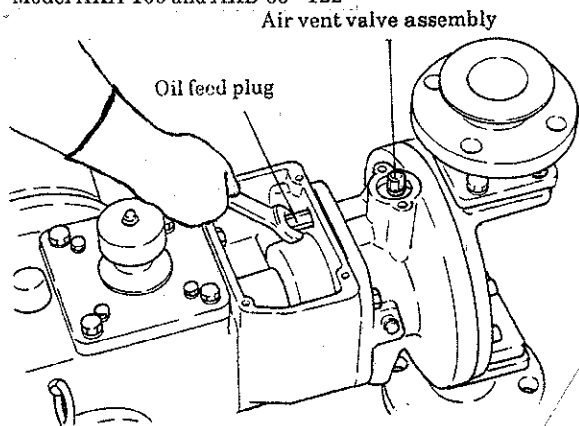

- ④ Clean the inside with new oil.
- ⑤ Wind sealing tape around the drain plugs and attach them to the bracket, cylinder head and driving unit.
- ⑥ Set the stroke at 0%.
- ⑦ Slowly inject suitable oil into the bracket, so as not to cause foaming. Fill oil up to the mid-position of the oil gauge of the driving unit and leave it as it is for about 5 minutes.
Please note that if the plug of the driving unit is not replaced by the air breather provided, oil cannot flow into the driving unit via the connecting hole. (See "Installation," Item 6.)

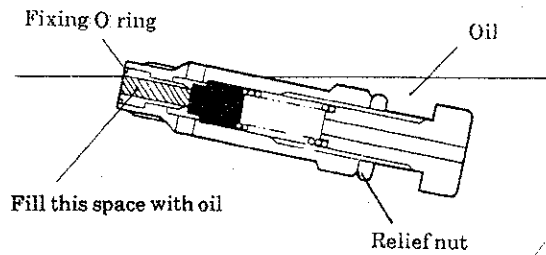

- ⑧ Attach the relief valve (or the oil feed plug in the Model AXA-100 and AXB-85~122).

Make sure to fit the relief valve only after filling in oil in its tip portion.

Tighten the relief valve (or the oil feed plug in the Model AXA-100 and AXB-85~122) with a wrench, until it reaches the innermost position. At that time, make sure to insert the O ring.

- ⑨ Install the air vent valve assembly. After confirming that it is attached with the O ring, tighten it with a wrench until it reaches the innermost position.

- ⑩ All the steps for oil change have now been completed, but the pump should be run for adjustment in order to let residual air in the pressure-oil chamber out through the automatic air vent assembly. For the run for adjustment, see the "Adjustment" section on page 36.

■ Inspection and Change of Seal Liquid in Insert Chamber (Double diaphragm type)

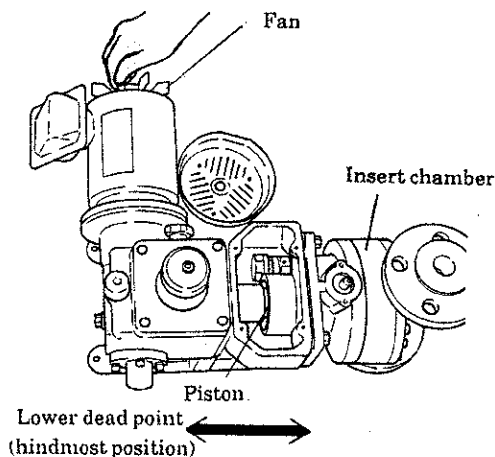

Usually, seal liquid in the insert chamber need not be checked or changed. If it becomes necessary to check or change the seal liquid, take the following steps without removing the pump head and the first diaphragm.

- ① Stop the pump and take measures to prevent pressure from being applied to the pump. Next, set the stroke at 100%.
- ② Detach the drain plug from the bracket and let the oil out.
- ③ Remove the fan cover of the motor and turn the fan by hand, or remove the motor and rotate the coupling by hand to bring the piston to lower dead centre (its hindmost position).
- ④ Remove drain plug (upper) and drain plug (lower) of the insert chamber and drain the seal liquid.

- ⑤ Firmly fit drain plug (lower) wound with sealing tape into the insert chamber.
 - ⑥ Inject seal liquid slowly into the hole for drain plug 1 to fill the insert chamber with seal liquid (up to the upper side of the screw hole) and leave it as it is for about 15 minutes. If the liquid surface lowers while waiting, oil should be added to make up for the decrease.
 - ⑦ Firmly fit drain plug (upper) wound with sealing tape.
 - ⑧ Attach the drain plug to the bracket, and pour a prescribed amount of oil into it. (See “Quantity of Oil to be Changed” on page 21.)
 - ⑨ After completing steps 1 to 8 above, run the pump for about 5 minutes.
To remove the pump head and the first diaphragm in order to change a diaphragm or the piston O ring, follow the instructions in the “Disassembly, Reassembly and Adjustment” section.
- To replace the O ring for piston or diaphragm, or to remove the pump head or first diaphragm, do it as instructed in “Disassembly, Reassembly and Adjustment” on page 27.

Problem	Motor does not move.	Discharge is insufficient or excessive.	Discharge is unstable.	Amperage of motor exceeds rating.	Liquid is not discharged.	Discharge pressure does not rise.	Liquid leaks.	Excessive vibrations and/or noise	Oil leaks.	High temperature of driving unit	Remedy
Cause											
Motor out of order.	<input type="checkbox"/>			<input type="checkbox"/>							Replace it.
Breaks or faulty connection	<input type="checkbox"/>			<input type="checkbox"/>							Connect or replace wire.
Power fuse melted.	<input type="checkbox"/>			<input type="checkbox"/>							Find out cause and take suitable action.
Voltage lowered.	<input type="checkbox"/>			<input type="checkbox"/>							Find out cause and take suitable action.
Insufficient NPSH (cavitation)	<input type="checkbox"/>	<input type="checkbox"/>	<input type="checkbox"/>	<input type="checkbox"/>	<input type="checkbox"/>			<input type="checkbox"/>			Review suction requirements.
Abrasion of valve seat	<input type="checkbox"/>	<input type="checkbox"/>	<input type="checkbox"/>	<input type="checkbox"/>	<input type="checkbox"/>						Replace it.
Valve blocked with foreign matter.	<input type="checkbox"/>	<input type="checkbox"/>	<input type="checkbox"/>	<input type="checkbox"/>	<input type="checkbox"/>						Disassemble and clean.
Suction piping and strainer blocked.	<input type="checkbox"/>	<input type="checkbox"/>	<input type="checkbox"/>	<input type="checkbox"/>	<input type="checkbox"/>						Disassemble and clean.
Stroke setting dial out of place.	<input type="checkbox"/>	<input type="checkbox"/>	<input type="checkbox"/>	<input type="checkbox"/>	<input type="checkbox"/>						Readjust.
Liquid overfeed due to insufficient differential pressure.	<input type="checkbox"/>	<input type="checkbox"/>	<input type="checkbox"/>	<input type="checkbox"/>	<input type="checkbox"/>						Increase the differential pressure.
Fluctuation in no. of strokes of pump	<input type="checkbox"/>	<input type="checkbox"/>	<input type="checkbox"/>	<input type="checkbox"/>	<input type="checkbox"/>						Examine power source, motor and gear reducer.
Overload (excessive discharge pressure)	<input type="checkbox"/>	<input type="checkbox"/>	<input type="checkbox"/>	<input type="checkbox"/>	<input type="checkbox"/>				<input type="checkbox"/>		Examine discharge piping system.
Improper specifications of power supply	<input type="checkbox"/>	<input type="checkbox"/>	<input type="checkbox"/>	<input type="checkbox"/>	<input type="checkbox"/>						Investigate.
Air sucked by suction side piping.	<input type="checkbox"/>	<input type="checkbox"/>	<input type="checkbox"/>	<input type="checkbox"/>	<input type="checkbox"/>						Inspect piping and mend it.
Liquid handled changed.	<input type="checkbox"/>	<input type="checkbox"/>	<input type="checkbox"/>	<input type="checkbox"/>	<input type="checkbox"/>			<input type="checkbox"/>			Review pump specifications.
Pressure gauge defective.	<input type="checkbox"/>	<input type="checkbox"/>	<input type="checkbox"/>	<input type="checkbox"/>	<input type="checkbox"/>						Replace it.
Mouth of pressure gauge clogged with dirt.	<input type="checkbox"/>	<input type="checkbox"/>	<input type="checkbox"/>	<input type="checkbox"/>	<input type="checkbox"/>						Clean it.
Leak from safety valve	<input type="checkbox"/>	<input type="checkbox"/>	<input type="checkbox"/>	<input type="checkbox"/>	<input type="checkbox"/>						Readjust set pressure of safety valve.
Improper lubricating oil used for driving unit.	<input type="checkbox"/>	<input type="checkbox"/>	<input type="checkbox"/>	<input type="checkbox"/>	<input type="checkbox"/>			<input type="checkbox"/>			Check amount, type and cleanliness of oil.
Oil seal/O ring out of order.	<input type="checkbox"/>	<input type="checkbox"/>	<input type="checkbox"/>	<input type="checkbox"/>	<input type="checkbox"/>				<input type="checkbox"/>		Replace them.
Valve gasket or gasket of fitting out of order.	<input type="checkbox"/>	<input type="checkbox"/>	<input type="checkbox"/>	<input type="checkbox"/>	<input type="checkbox"/>						Replace it.
Improper amount of seal liquid (only for WL models)	<input type="checkbox"/>	<input type="checkbox"/>	<input type="checkbox"/>	<input type="checkbox"/>	<input type="checkbox"/>						Check and seal liquid again.
Diaphragm deformed.	<input type="checkbox"/>	<input type="checkbox"/>	<input type="checkbox"/>	<input type="checkbox"/>	<input type="checkbox"/>						Replace it.
Oil leaks from relief valve.	<input type="checkbox"/>	<input type="checkbox"/>	<input type="checkbox"/>	<input type="checkbox"/>	<input type="checkbox"/>						Check and repair or replace it.
Malfunctioning of oil feed valve assembly	<input type="checkbox"/>	<input type="checkbox"/>	<input type="checkbox"/>	<input type="checkbox"/>	<input type="checkbox"/>						Check and repair or replace it.
Air not let out of pressure-oil chamber.	<input type="checkbox"/>	<input type="checkbox"/>	<input type="checkbox"/>	<input type="checkbox"/>	<input type="checkbox"/>						Let air out.
Malfunctioning of automatic air vent mechanism	<input type="checkbox"/>	<input type="checkbox"/>	<input type="checkbox"/>	<input type="checkbox"/>	<input type="checkbox"/>						Disassemble and clean or replace it.
Improper tightening torque of pump head fastening bolts	<input type="checkbox"/>	<input type="checkbox"/>	<input type="checkbox"/>	<input type="checkbox"/>	<input type="checkbox"/>				<input type="checkbox"/>		Retighten it with prescribed torque.

10 Disassembly, Assembly and Adjustment

While disassembling, reassembling or adjusting the pump, refer to the “Structure and Names of Parts” section. Since the driving unit was completely adjusted when it was assembled, do not disassemble it. If the need to disassemble it arises, please call us.

■ Disassembly

- ◇ Let the liquid out of the suction side and discharge side pipes and close the valves. Then remove the pipes. At that time, watch for liquid dripping.
- ◇ Detach the inlet and outlet, and take out the valves. If unusual scratches or abrasions are seen on the suction valve, discharge valve, etc., it should be replaced. While disassembling, be careful as liquid remaining in the pump chamber and inside the valves comes out and some types of liquid do harm to persons and parts.

Pump Head Size	SUS Type	PVC Type
D3·D15	Detach valve caps.	Remove inlet and outlet. (Loosen them by hand or with belt wrench.)
D35·D90	Remove fastening bolts of setting flange.	Screw two M6 bolts into valve retainer to loosen it, and inlet and outlet are ready to be removed.
D170·D250		
D500		Remove inlet and outlet. (Loosen them by hand or with belt wrench.)

<SUS type> Models D3 and D15

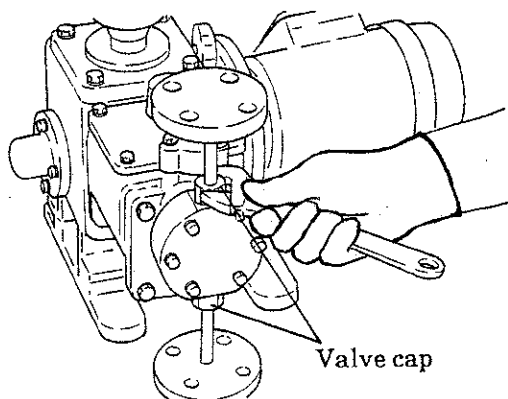

<SUS type> Models D35~D500

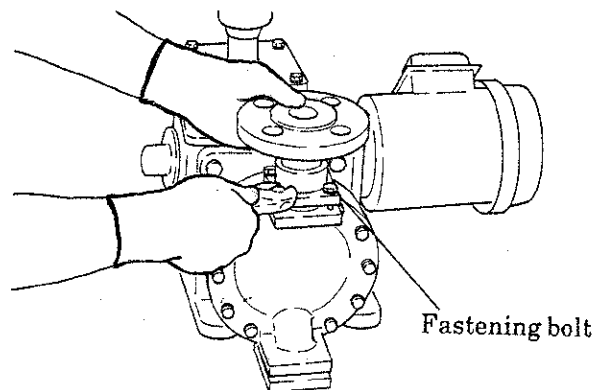

<PVC type> Models D3~D90 and D500

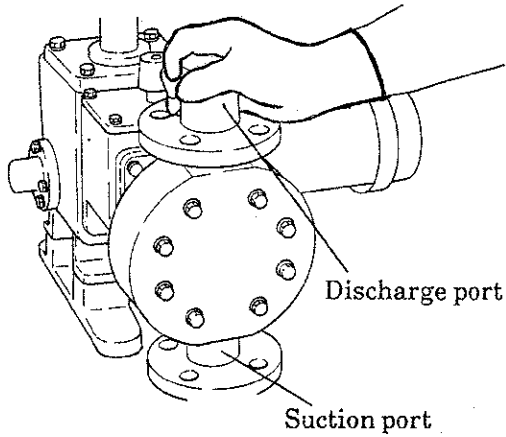

<PVC type> Models D170 and D250

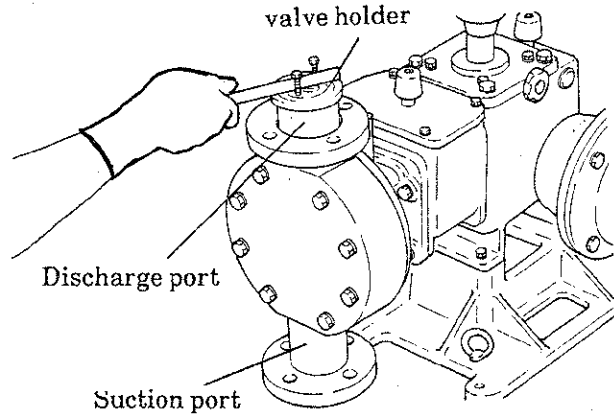

- ④ Remove the drain plugs of the cylinder head and bracket, and drain the oil. Prior to draining oil, place polyethylene vessel or the like under the drain plug to collect oil.

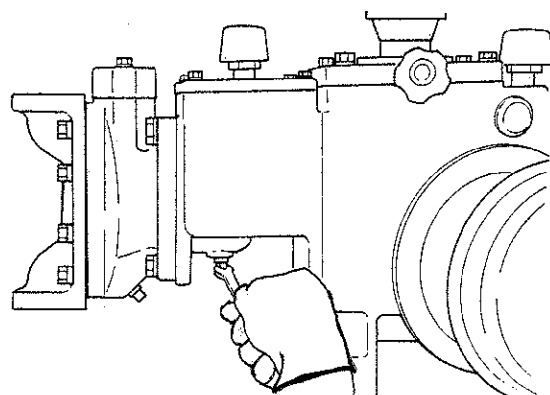
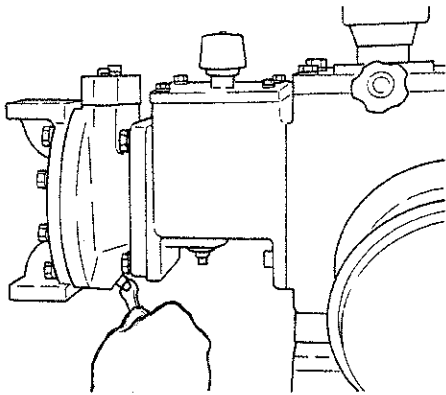

*④ (This applies only to the double diaphragm type WL models.)

Detach drain plug (upper) and drain plug (lower) of insert chamber and drain the sealed liquid in the chamber. Put polyethylene vessel or the like under the insert chamber to collect liquid.

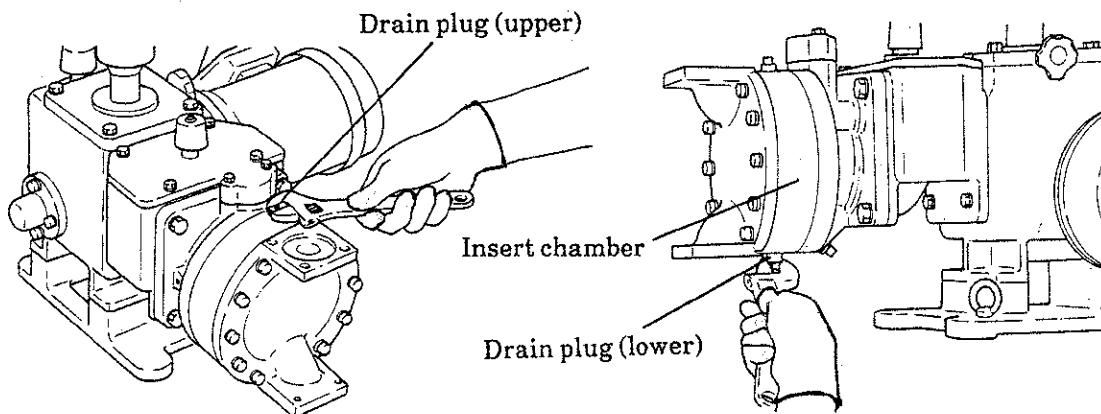

- Description marked with ※ applies to the WL models only. Disregard it in the case of DL models.

- ◇ Loosen the fastening bolts (16) of the pump head and detach the pump head (1).

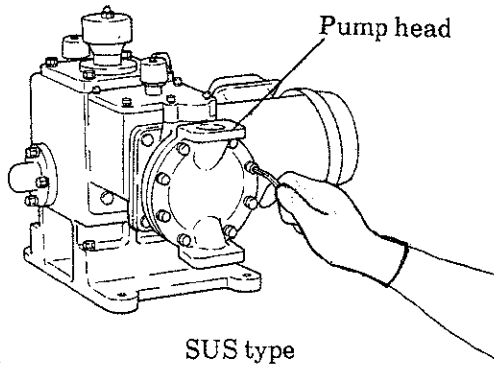

Please note that the front plate (25) in the SUS Type DI models (single diaphragm), or the pump head spacer (26) in the WL models (double diaphragm) comes off together with the pump head. Note: take care so as not to damage the diaphragm seal portion of the pump head.

- ◇ Remove the diaphragm (first diaphragm in the DL models) (111). Be careful not to damage it. If scratches or other abnormalities are found in the diaphragm, it should be replaced with a new one.

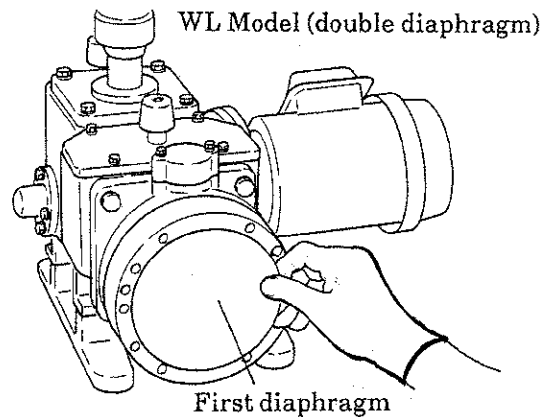
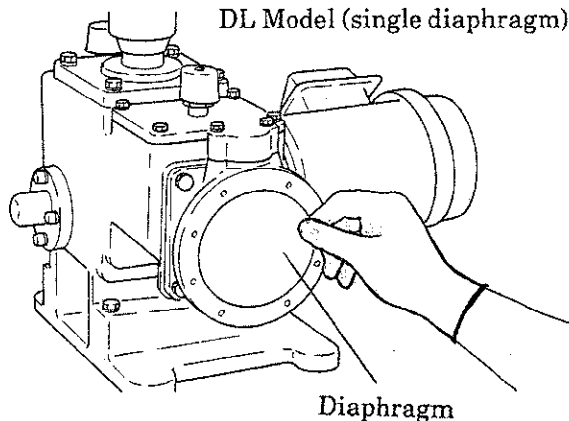

- *◇ In a WL model, loosen the fastening bolts (115) of the insert chamber, and remove the insert chamber (114). Be careful because the front plate (25) comes off together with it.

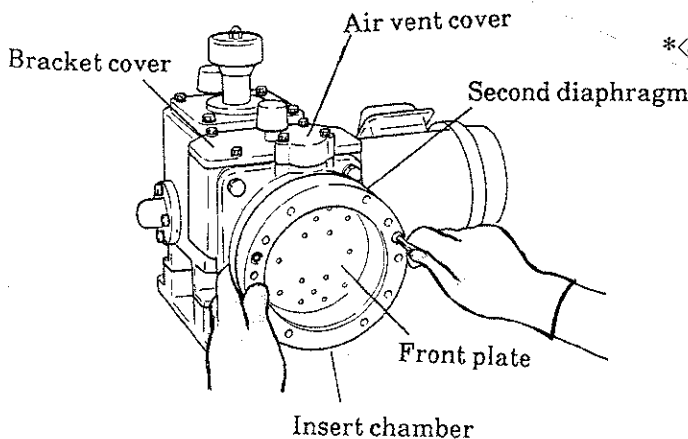

- *◇ Remove the second diaphragm (111) in the same manner as the first diaphragm.

- Description marked with ※ applies to the WL models only. Disregard it in the case of DL models.

- ◆ Remove the bracket cover (162) and the air vent cover (134), and remove the relief valve and the air vent valve assembly using a wrench.

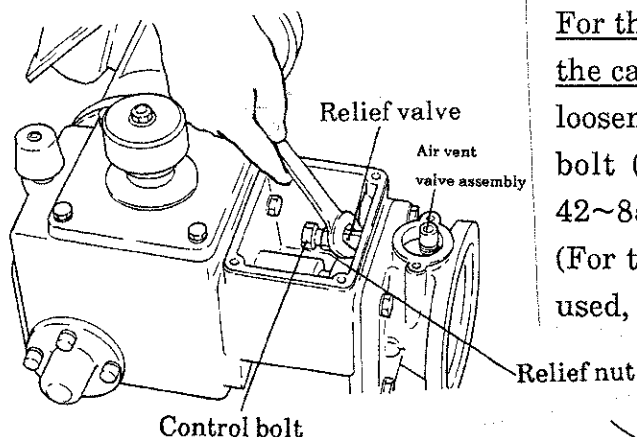

For the removal of the relief valve, loosen the casing and detach it as a unit. Do not loosen the relief nut and pressure control bolt (the cap in AXK-52~68, AXA-42~85, and AXB-52~68).

(For the nominal size of the wrench to be used, see "Oil Change Procedure," Item 3.)

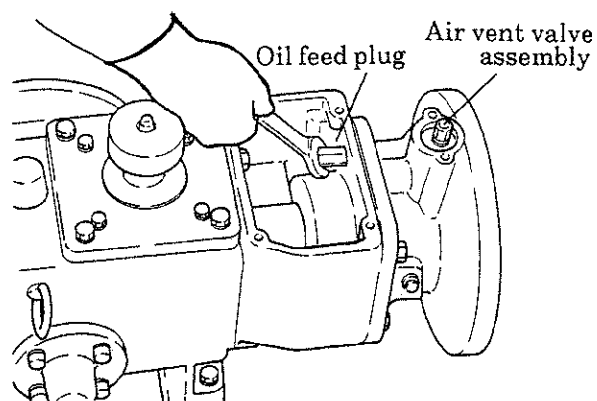

- ◆ Remove the cylinder head (101). The supply switching valve assembly need not be detached.

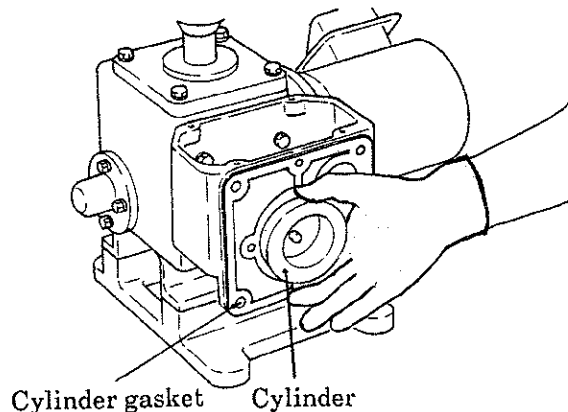
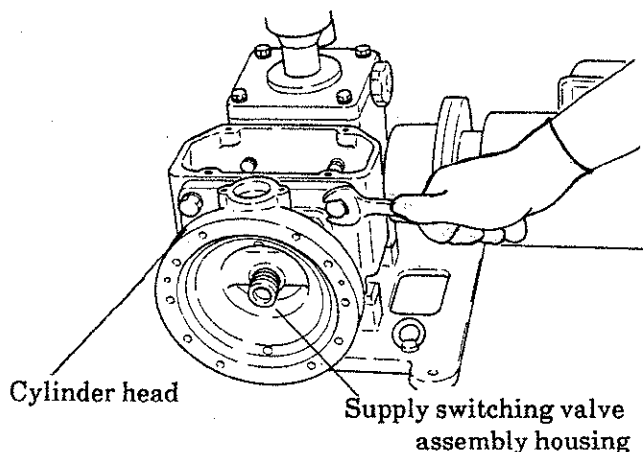

- ◆ Remove the cylinder gasket. Draw out the cylinder while rotating it. Take care not to scratch the sliding portion of the piston.

- ◆ For models AXJ-42, AXK-42~68, AXA-52~100, and AXB-68~122.
Remove the piston. At that time, do not detach the switching valve for supply assembly.
Check the piston O ring, and replace it if it is damaged or worn away.

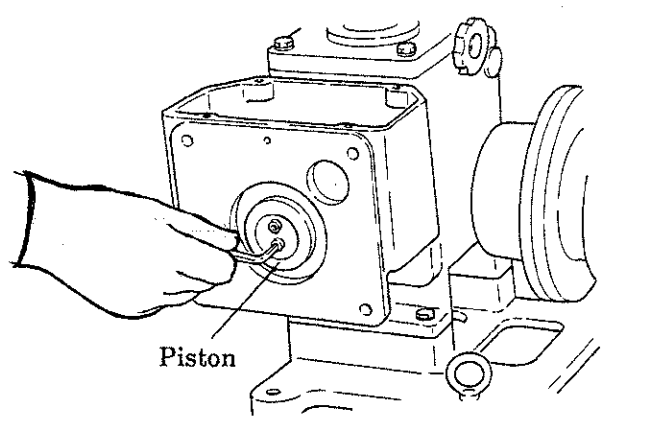

■ Reassembly

For reassembly, follow the steps of disassembling the other way around.

- ① Wash the parts, and wipe off the dirt and oil.
- ② Wind the drain plugs with sealing tape and attach them to the bracket and cylinder head.
- ③ Models AXJ-42, AXK-42~68, AXA-52~100, and AXB-68~122
Attach the piston to the crosshead (119). At that time, clamp the hexagon socket head bolt (121) fully so that it will not become loose. Do not forget to mount the piston O ring (118) and the crosshead O ring (120).
- ④ Apply oil to the sliding surfaces of the piston and the cylinder, and mount the cylinder and the cylinder gasket. For this, the cylinder gasket should be positioned relative to the four screw holes in the bracket, and fixed. Put the cylinder-fixing O ring (127) in the hole for cylinder insertion to prevent it from slipping off.
- ⑤ Mount the cylinder head (attached with the replenishment switching valve for supply assembly). Use fastening bolts of the strength classification 8T (JIS B1051 "8" is marked on the head of the hexagon bolt). Confirm that the slide valve (139) of the supply switching valve assembly slides smoothly when pressed with the finger, and position it so that one of its holes faces upward.

- ⑥ Fit the rear plate (110) into the groove of the cylinder head. The mounting orientation is as shown in the diagram below. One of the holes on the outermost periphery of the spherical surface should be positioned on the center top.

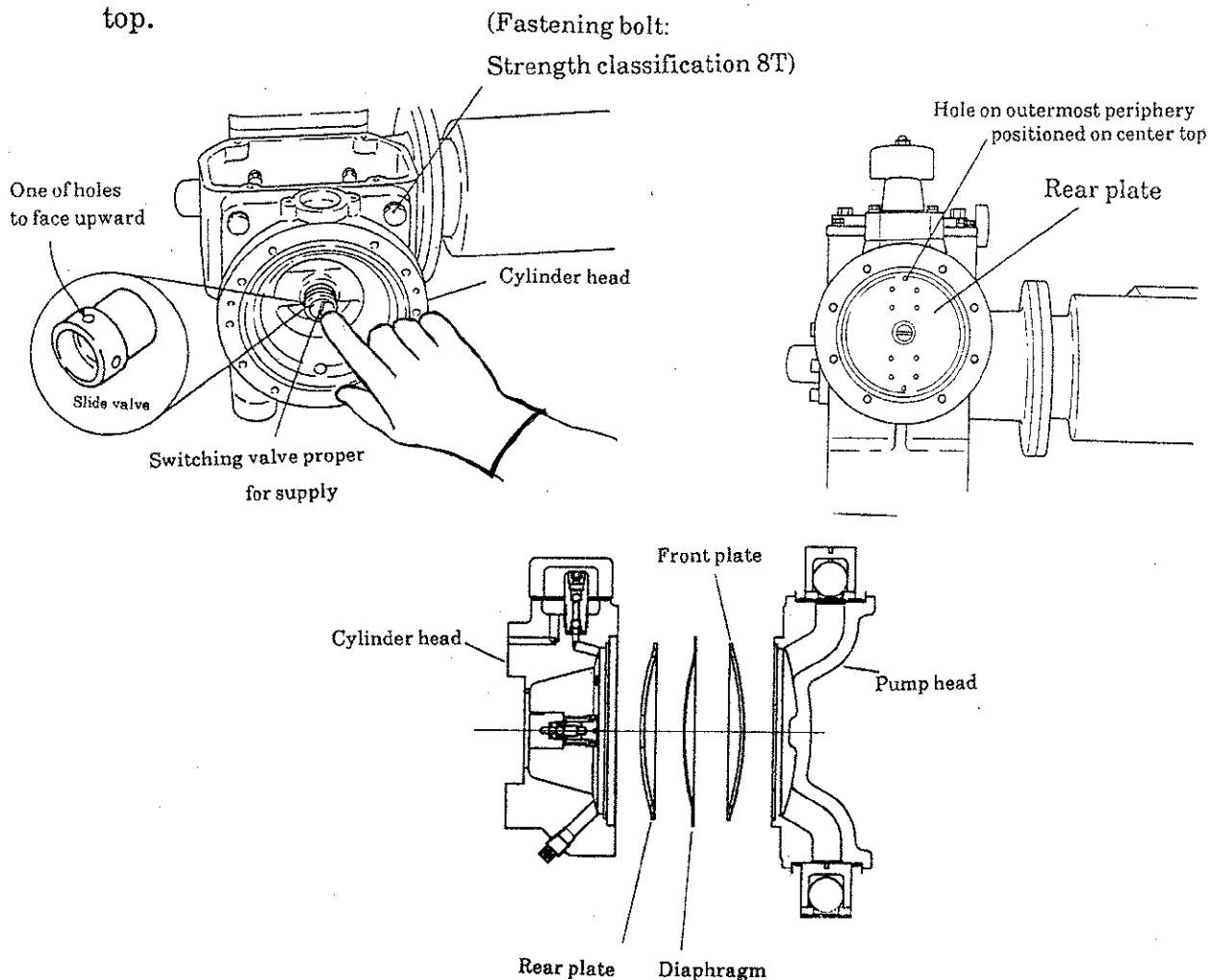

- ⑥ Fit the diaphragm (second diaphragm in the double diaphragm type) into the hole of the cylinder head (114).

- *⑥ Attach the drain plug (171 lower one, wound with sealing tape) into the insert chamber (114).

(Note) Press the drain plug in firmly. Drain plugs 1 and 2 are identical.

- The items marked with * apply to the WL models only. Disregard them in the case of DL models.

- *⑥ Fit the front plate (25) into the groove of the insert chamber, and mount the insert chamber on the cylinder.

- ① Tighten the insert chamber fastening bolts (115) uniformly to avoid a one-sided clamp.

- ② The mounting orientations of the diaphragms, rear and front plates, and how they are assembled are shown below. Make sure that one of the holes on the outermost periphery of the spherical surface of each plate is positioned on the center top.
- ③ If a diaphragm is damaged or deformed, replace it with a new one.
- ④ If the spherical surface of a diaphragm has slight creases and unevenness, smooth them out with the hands or dip the diaphragm in water with a temperature of 70~80°C for 30 seconds and cool it in cold water to reshape the spherical surface before the diaphragm is assembled. If a creased or damaged diaphragm is used, the insert chamber cannot hold the correct amount of sealed liquid and an accurate discharge cannot be expected.

*◆ Fit the first diaphragm into the hole of the insert chamber. ②, ③ and ④ of Item ◆ apply to the first diaphragm, too.

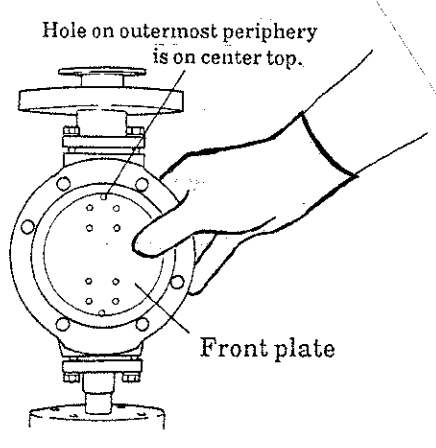
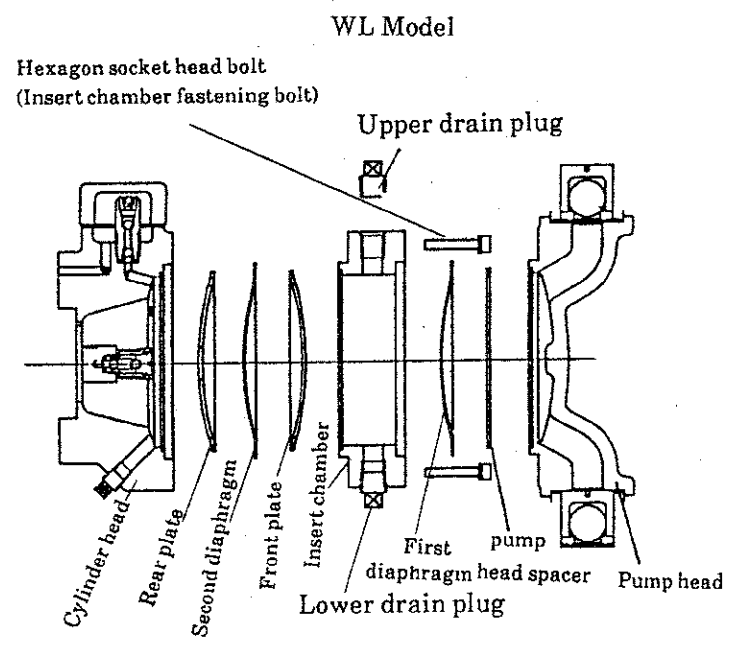

◆ Fit the front plate (25) into the groove of the stainless steel pump head (pump head spacer (26) in the case of the double diaphragm type). The mounting orientation of the front plate is as illustrated below. Make sure that one of the holes on the outermost periphery of the spherical surface is positioned on the center top.

◆ Assemble the pump head and the cylinder head (insert chamber in the case of the double diaphragm type) together and fix it by tightening the bolts (16) uniformly. The tightening procedure is as follows:

- ① First, tighten them lightly by the use of a hexagon rod wrench in the SUS types (or a wrench in the PVS types).
- ② Then, tighten further until a torque in the following table is reached. (Additional tightening should be done dividedly in four or five times to reach a proper level.)

Note: The bolts should be tightened diagonally in the numerical order shown below.

Note: Note that excessive tightening will damage the diaphragm or cause other problems.

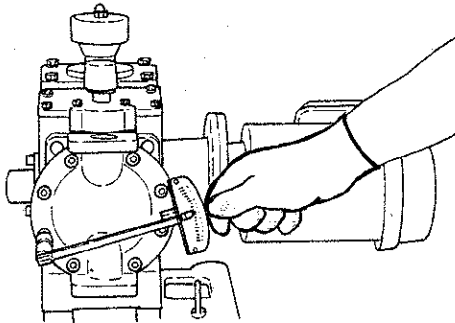

• Tightening Torque Unit: N·m
(Common to DL and WL) {kgf·cm}

Pump Head Size \ Pump Type	S6, VH, VS, VC	TC
D3, D15	2.5 {25}	
D35, D90	7.4 {75}	
D170, D250	15.2 {155}	
D500	23.5 {240}	

● Order for clamping

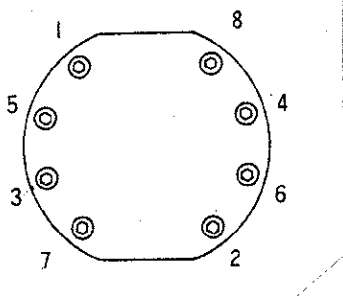

*◆ Gradually pour seal liquid into the hole for drain plug (171 upper) of the insert chamber (114) to fill the insert chamber with liquid (up to the upper side of the screw hole). Leave it as it is for about 5 minutes, during which if the liquid surface lowers, add liquid to fill the insert chamber and then press drain plug (171 upper, wound with sealing tape) into the insert chamber.

Quantity of Sealed Liquid (Estimate) (Unit: ml)

Pump Head Size \ Pump Type	D3	D15	D35	D90	D170	D250	D500
	W L	36	88	220	470	690	1050

◆ Attach the suction valve, discharge valve, inlet and outlet valves to the pump head, paying attention to the following points:

- Assemble the suction valve and the discharge valve as shown in the exploded view of the pump head unit (see pages 40 and 41). The orientations and order of mounting the valve seat and the valve guide need particularly close attention.
- In a stainless steel type pump head whose inlet and outlet are fixed by a setting flange, make sure that the bolts are uniformly fixed to avoid a one-sided clamp.
- In a PVC type pump (VS, VH or VC model), the inlet and the outlet have to be pressed in reliably by hand or with a belt wrench to reach the A surface of the pump head.

In a pump with a pump head size of D170 or D250, attach the valve retainer (20) reliably by hand with two bolts (M6) screwed into the tapped holes.

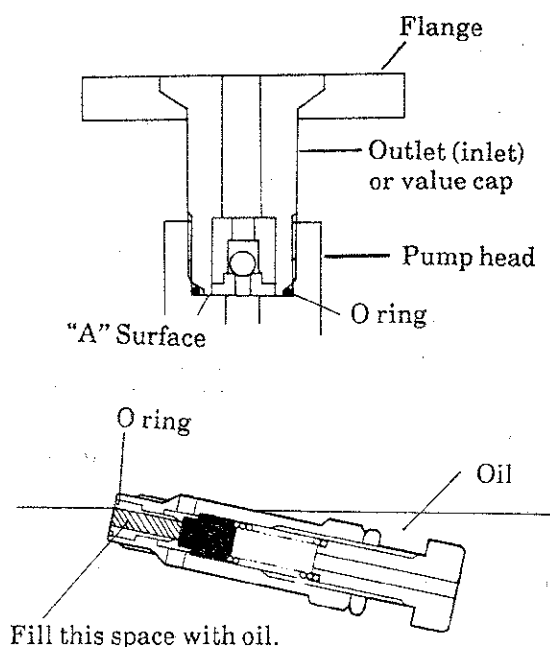

◆ Set the stroke at 0%.

◆ Slowly inject suitable oil into the bracket to avoid causing it to foam. Add oil until it comes to the middle position of the oil gauge of the driving unit, and leave it as it is for about 5 minutes. (For the suitable types of oil, see the "Periodic Inspection" section.) It should be noted that if the plug of the driving unit is not replaced by the air breather provided, oil does not flow into the driving unit via the connection hole. (See "Installation," Item 6.)

- ◆ Attach the relief valve to the cylinder head (or the oil feed plug in the case of Model AXA-100 and AXB-85~122).

The relief valve should always be installed after it is immersed in oil to be filled with oil. Tighten the relief valve (or the oil feed plug) with a wrench until it comes to the innermost position. At that time, do not forget to insert the O ring. (For the nominal size of the wrench, see "Oil Change Procedure," Item 3.)

- ◆ Fit the air vent valve assembly.

Make sure to insert the O ring and tighten the assembly with a wrench (nominal size: 13) until it reaches the innermost position.

■ Adjustment of the Amount of Hydraulic Oil

After completing reassembling, the pump should be run for adjustment to let the residual air in the pressure-oil chamber out through the automatic air vent valve assembly so that oil can be at a prescribed level. A thorough adjustment run is highly recommended. Without it, the metering precision may be noticeably reduced. Make an adjustment run before laying pipes, in a no-load condition.

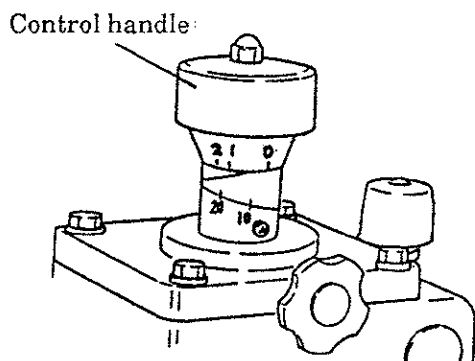

- ◆ Set the stroke at 100% and make a run for 2~3 minutes.
Turn the control handle and set it at 100%.
- ◆ Decrease the stroke to 30% and run the pump for 2~3 minutes.
- ◆ Reset the stroke at 100% and run the pump for 2~3 minutes.
- ◆ Repeat an adjustment run with changed strokes more than three times.
- ◆ When the above steps have been completed, confirm that oil is discharged from the automatic air vent assembly. (See the diagram below.)

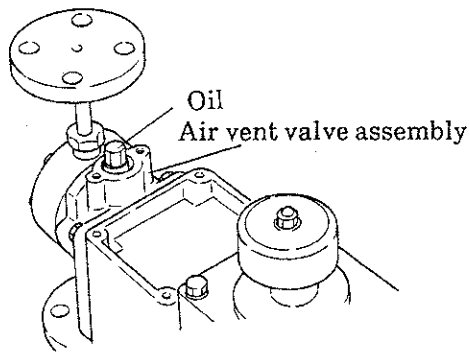

- ◇ If the oil level decreases after being checked, add oil up to the middle position of the oil gauge of the driving unit and attach the bracket cover and the air vent cover.
- ◇ Next, make another no-load run for about 10 minutes under a no-load condition, with the stroke at 100%. The adjustment procedure has now been completed.
- ◇ Lay the suction and discharge pipes and put the pump in full operation. While the pump is running, never throttle or close the valve on the suction side.

■ Handling of Relief Valve

Since the relief valve has been set in accordance with the discharge pressure of requested specifications, the relief nut (151) should never be loosened. When oil is changed or the relief valve is removed for inspection, the assembly has to be removed intact.

- Avoid using the pump under a discharge pressure different from the value specified at the time of purchase.
- If a change in specifications is planned, please call us. For an increased discharge pressure, comprehensive reconfirmation, including such items as pressure tightness of the liquid-contacting parts, power for the motor and loads on both ends of the mechanical parts is required.

11 Wear Parts

When the pump is operated continuously for a long period of time, appropriate spare parts are needed. It is recommended that you always have expendable parts ready. When parts are ordered, we need the following information:

- ① the name of the product and product no. (as per the diagrams in this instruction manual)
- ② the model code and manufacturing no. of the pump (written on the nameplate)
- ③ if approved diagrams have been submitted to you, the diagram no.

No.	Name	Expected Life (Reference Value)	DL-WL	DL-WL	DL-WL	DL-DL	DL-WL	DL-WL	DL-WL
			3S6	15S6	35S6	90S6	170S6	250S6	500S6
			Quantity						
3	Valve	1 year	2						
2	Valve seat		2						
5	Valve gasket		6	2					
24	Fitting gasket		2						
111	Diaphragm		1 (2 for WL)						

No.	Name	Expected Life (Reference Value)	DL-WL	DL-WL	DL-WL	DL-DL	DL-WL	DL-WL	DL-WL
			3VHVC	15VHVC	35VHVC	90VSVC	170VSVC	250VSVC	500VSVC
			Quantity						
3	Valve	1 year	2						
2	Valve seat		2						
12	O ring		2						
21	O ring		2						2
111	Diaphragm		1 (2 for WL)						

Piston O rings (no. 118)

Piston Diameter	Expected Life (Reference Value)	O Ring Size
07	1 year	JIS B 2401 P4
11		JIS B 2401 P8
15		JIS B 2401 P11
22		JIS B 2401 P18
30		JIS B 2401 P24
42		JIS B 2401 P36
52		JIS B 2401 P46
68		JIS B 2401 P58
85		JIS B 2401 P75
100		JIS B 2401 P90
122		JIS B 2401 P122

Note: The lives of spare parts depend on the pressure, temperature, properties and the like of liquid to be handled. The values in the above table are estimates from continuous operation with clean water at the normal temperature. Use these figures as a guideline.

12 Parts Description and Exploded View

■ Pump Head Unit

● PVC types
(pump head sizes
D3, 15, 35 and 90)

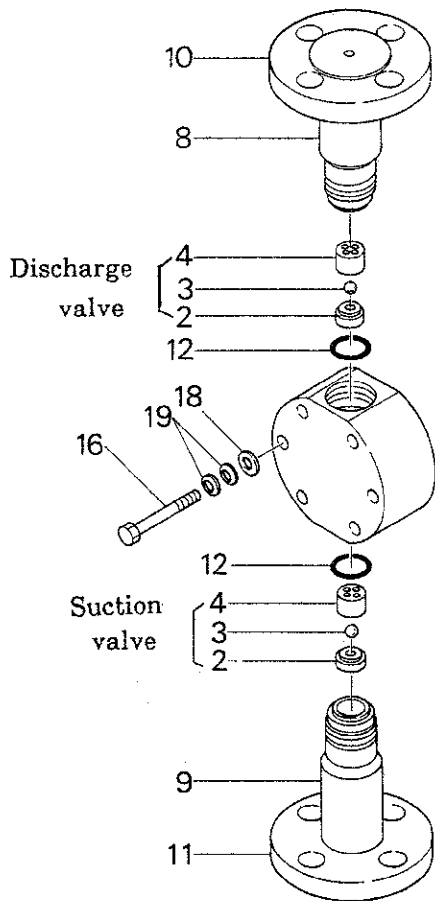

● PVC types
(pump head sizes
D170 and 250)

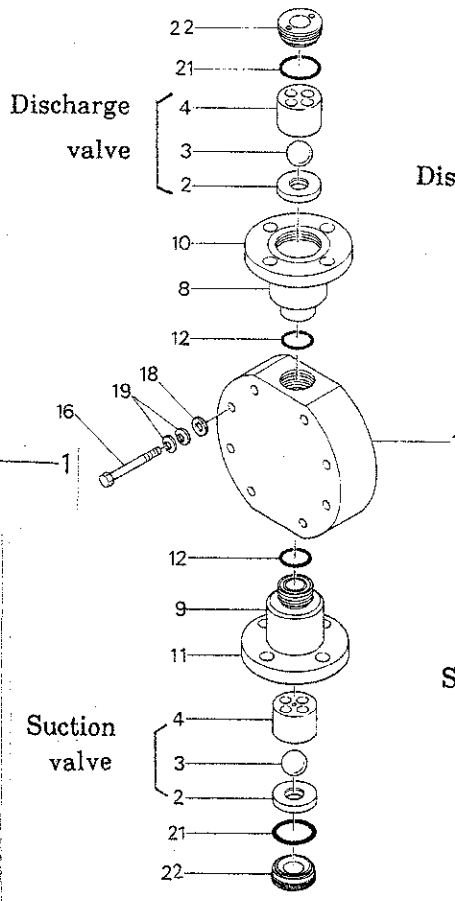

● PVC types
(pump head sizes
D500)

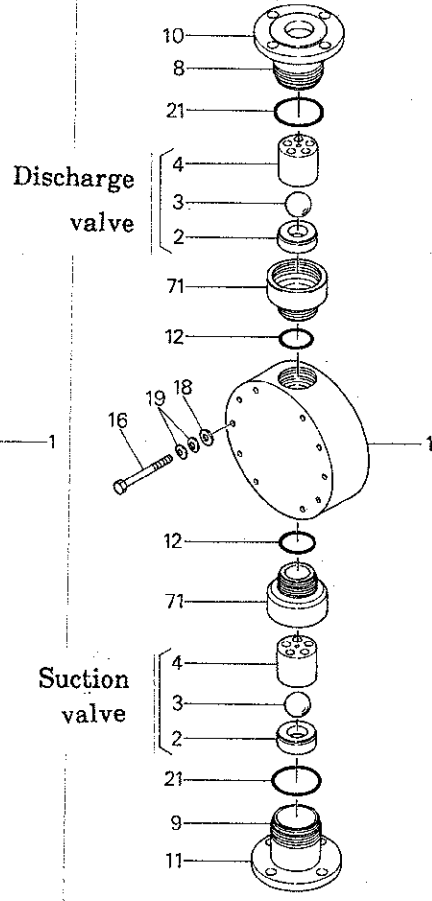

No.	Name	Quantity
1	Pump head	1
2	Valve seat	2
3	Valve	2
4	Valve guide	2
8	Outlet	1
9	Inlet	1
10	Flange	1

No.	Name	Quantity
11	Flange	1
12	O ring	2
16	Hexagon head bolt	8 (Note 1)
18	Plate washer	8 (Note 1)
19	Coned disk spring	16 (Note 2)
21	O ring	2
22	Valve retainer	2
71	Valve case	2

Note 1: Six in pump head size D3 and ten in D90, 250, and 500.

Note 2: Twelve in pump head size D3 and twenty in D90, 250, and 500.

● SUS types (pump head sizes D3 and 15)

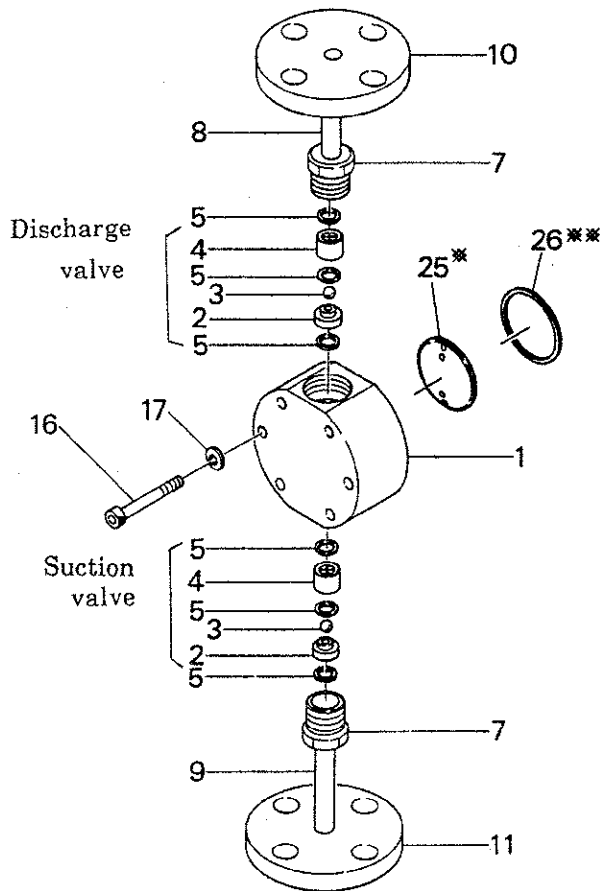

● SUS types (pump head sizes D35, 90, 170, 250 and 500)

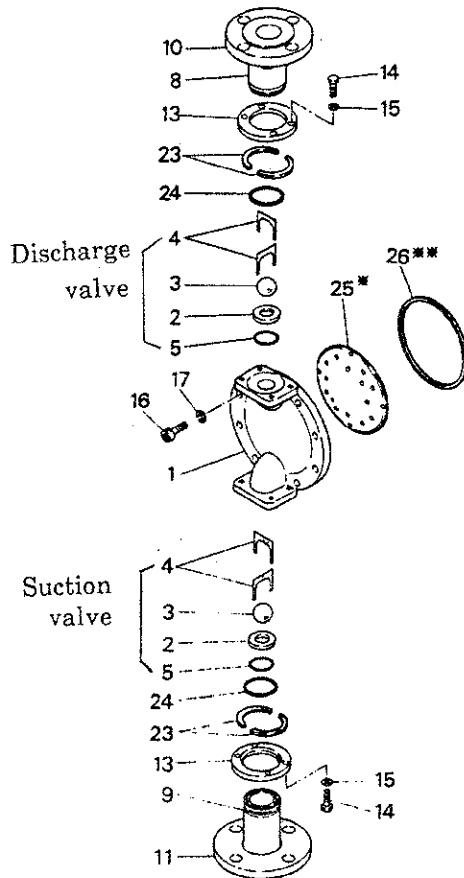

(Note) * 25 for DL types

** 26 for WL types

No.	Name	Quantity
1	Pump head	1
2	Valve seat	2
3	Valve	2
4	Valve guide	2 (sets)
5	Valve gasket	(6)
7	Valve cap	2
8	Outlet	1
9	Inlet	1
10	Flange	1
11	Flange	1

No.	Name	Quantity
13	Retaining flange	2
14	Hexagon bolt	8
15	Spring washer	8
16	Hexagon socket (head) bolt	8 (Note 1)
17	Spring washer	8 (Note 1)
23	Split ring	4
24	Fitting gasket	2
25	Front plate	1
26	Pump head spacer	1

Note 1: Six in pump head size D3 and ten in D90, 250 and 500.

■ Hydraulic Unit

The illustration shows completely disassembled condition to easily explain the construction, however, the pump must be disassembled to the extent which is instructed on the items "Maintenance and Inspection" and "Disassembly, Assembly and Adjustment" of this manual.

- AXJ-07~30, AXK-30 and AXA-42 types
- AXA-42 type

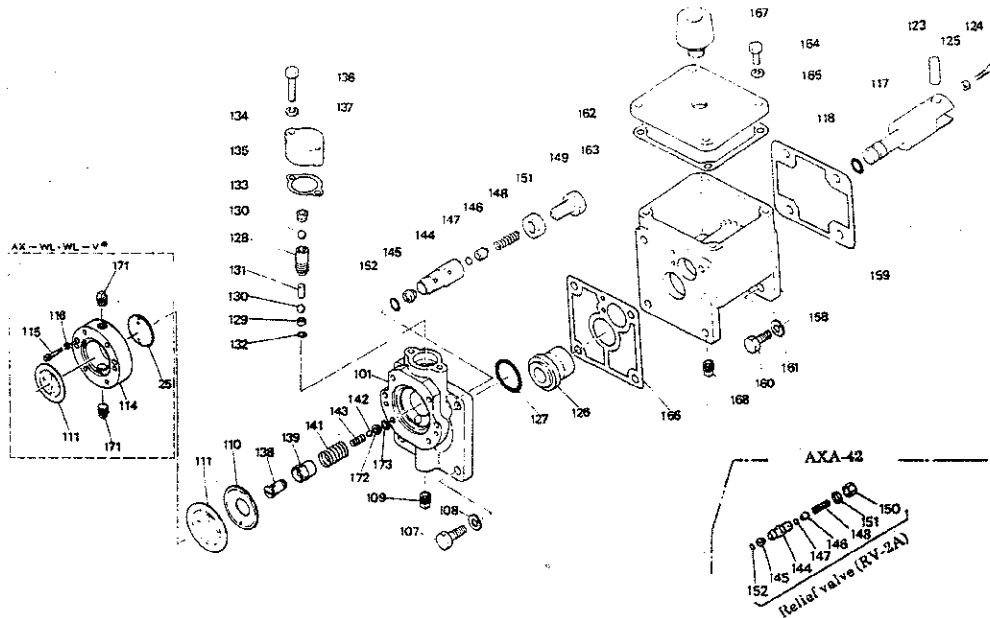

No.	Name	Quantity	No.	Name	Quantity	No.	Name	Quantity
*25	Front plate	1	129	Valve seat	1	149	Pressure control bolt	1
101	Cylinder head	1	130	Air vent valve	2	150	Cap	1
102	Hexagon socket set screw	1	131	Separate pin	1	151	Relief nut	1
107	Hexagon head bolt	4	132	O ring	1	152	O ring	1
108	Spring washer	4	133	Air vent plug	1	158	Bracket	1
109	Drain plug	1	134	Air vent cover	1	159	Case gasket	1
110	Rear plate	1	135	Air vent cover gasket	1	160	Hexagon head bolt	4
111	Diaphragm	1 (2 in WL)	136	Hexagon head bolt	2	161	Spring washer	4
*114	Insert chamber	1	137	Spring washer	2	162	Bracket cover	1
*115	Hexagon socket head bolt	2	138	Supply switching valve assembly housing	1	163	Cover gasket	1
*116	Spring washer	2	139	Slide valve	1	164	Hexagon head bolt	4
117	Piston	1	141	Spring	1	165	Spring washer	4
118	O ring	1	142	Check valve	1	166	Cylinder gasket	1
123	Crosshead pin	1	143	Check valve spring	1	167	Air breather	1
124	Hexagon head bolt	1	144	Case	1	168	Drain plug	1
125	Hexagon nut	1	145	Valve seat	1	*171	Drain plug	2
126	Cylinder	1	146	Valve base	1	172	Valve seat	1
127	O ring	1	147	Gasket	1	173	O ring	1
128	Air vent assembly housing	1	148	Spring	1			

Those marked by * are only for WL (double diaphragm) models.
102 is used only in AXJ-22~30, AXK-30 and AXA-42.

The illustration shows completely disassembled condition to easily explain the construction, however, the pump must be disassembled to the extent which is instructed on the items "Maintenance and Inspection" and "Disassembly, Assembly and Adjustment" of this manual.

- AXK-52~68, AXA-52~85, and AXB-68 types
- AXJ-42 types, AXK-42 types

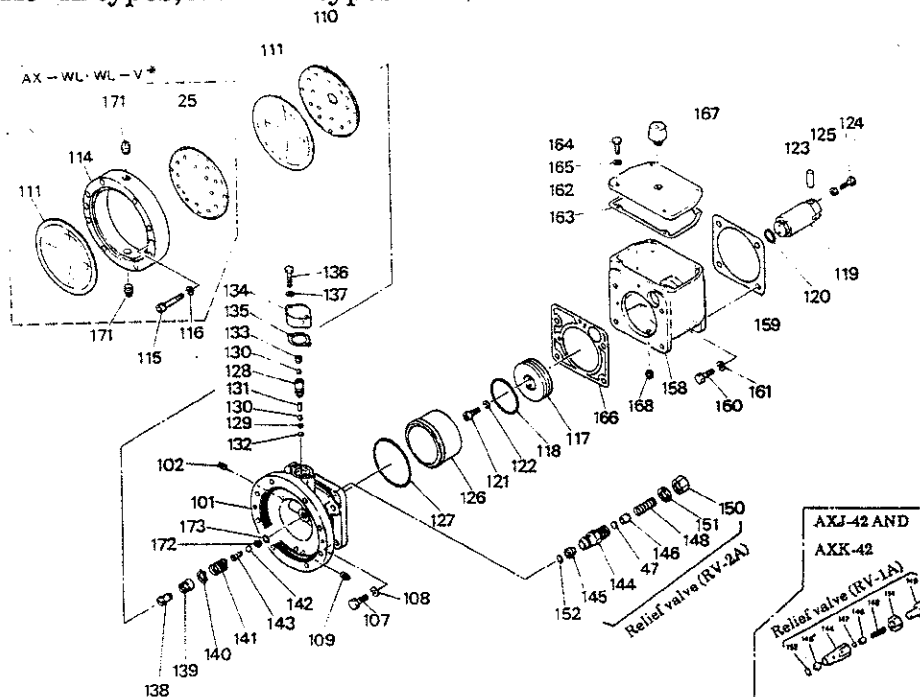

No.	Name	Quantity	No.	Name	Quantity	No.	Name	Quantity
*25	Front plate	1	127	O ring	1	148	Spring	1
101	Cylinder head	1	128	Air vent assembly housing	1	149	Pressure control bolt	1
102	Hexagon socket set screw	1	129	Valve seat	1	150	Cap	1
107	Hexagon head bolt	4	130	Air vent valve	2	151	Relief nut	1
108	Spring washer	4	131	Separate pin	1	152	O ring	1
109	Drain plug	1	132	O ring	1	158	Bracket	1
110	Rear plate	1	133	Air vent plug	1	159	Case gasket	1
111	Diaphragm	1 (2 in WL)	134	Air vent cover	1	160	Hexagon head bolt	4
*114	Insert chamber	1	135	Air vent cover gasket	1	161	Spring washer	4
*115	Hexagon socket head bolt	2	136	Hexagon head bolt	2	162	Bracket cover	1
*116	Spring washer	2	137	Spring washer	2	163	Cover gasket	1
117	Piston	1	138	Supply switching valve assembly housing	1	164	Hexagon head bolt	4
118	O ring	1	139	Slide valve	1	165	Spring washer	4
119	Crosshead	1	140	Stop ring	1	166	Cylinder gasket	1
120	O ring	1	141	Spring	1	167	Air breather	1
121	Hexagon socket head bolt	2	142	Check valve	1	168	Drain plug	1
122	Spring washer	2	143	Check valve spring	1	*171	Drain plug	2
123	Crosshead pin	1	144	Case	1	172	Valve seat	1
124	Hexagon head bolt	1	145	Valve seat	1	173	O ring	1
125	Hexagon nut	1	146	Valve base	1			
126	Cylinder	1	147	Gasket	1			

Those marked by * are only for WL (double diaphragm) models.

The illustration shows completely disassembled condition to easily explain the construction, however, the pump must be disassembled to the extent which is instructed on the items "Maintenance and Inspection" and "Disassembly, Assembly and Adjustment" of this manual.

● AXA-100, and AXB-85~122 type

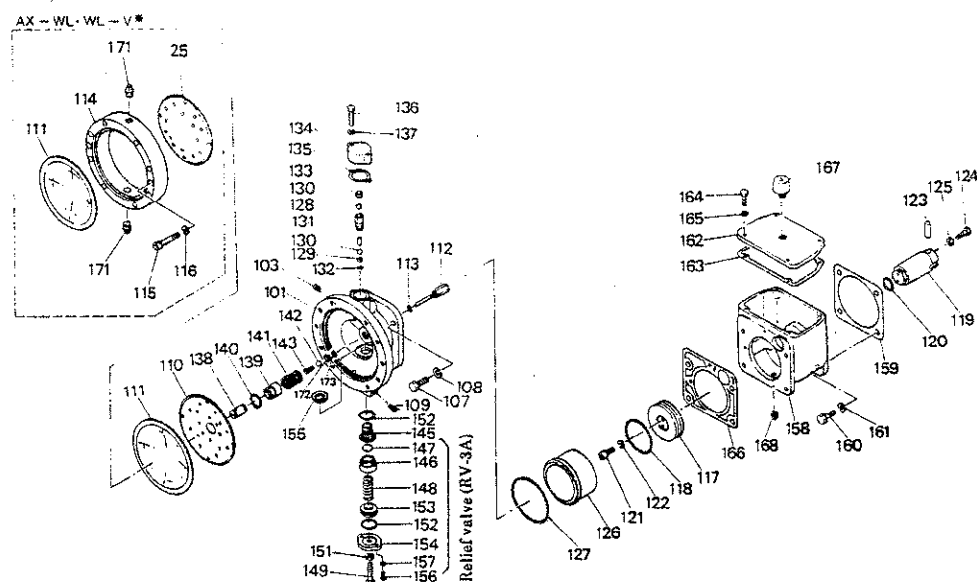

No.	Name	Quantity	No.	Name	Quantity	No.	Name	Quantity
*25	Front plate	1	126	Cylinder	1	149	Pressure control bolt	1
101	Cylinder head	1	127	O ring	1	151	Relief nut	1
103	Drain plug	1	128	Air vent assembly housing	1	152	O ring	2
107	Hexagon head bolt	4	129	Valve seat	1	153	Spring seat	1
108	Spring washer	4	130	Air vent valve	2	154	Relief valve cover	1
109	Drain plug	1	131	Separate pin	1	155	Bearing nut	1
110	Rear plate	1	132	O ring	1	156	Hexagon head bolt	2
111	Diaphragm	1 (2 in WL)	133	Air vent plug	1	157	Spring washer	2
112	Oil feed plug	1	134	Air vent cover	1	158	Bracket	1
113	O ring	1	135	Air vent cover gasket	1	159	Case gasket	1
*114	Insert chamber	1	136	Hexagon head bolt	2	160	Hexagon head bolt	4
*115	Hexagon socket head bolt	2	137	Spring washer	2	161	Spring washer	4
*116	Spring washer	2	138	Supply switching valve assembly housing	1	162	Bracket cover	1
117	Piston	1	139	Slide valve	1	163	Cover gasket	1
118	O ring	1	140	Stop ring	1	164	Hexagon head bolt	4
119	Crosshead	1	141	Spring	1	165	Spring washer	4
120	O ring	1	142	Check valve	1	166	Cylinder gasket	1
121	Hexagon socket head bolt	2	143	Check valve spring	1	167	Air breather	1
122	Spring washer	2	145	Valve seat	1	168	Drain plug	1
123	Crosshead pin	1	146	Valve base	1	*171	Drain plug	2
124	Hexagon head bolt	1	147	Gasket	1	172	Valve seat	1
125	Hexagon nut	1	148	Spring	1	173	O ring	1

Those marked by * are only for WL (double diaphragm) models.