

IWAKI
PNEUMATIC-DRIVEN BELLOWS PUMP

CFD-8T-B TYPE

Instruction Manual

⚠ Read this manual before use of product

Thank you for having purchased the Iwaki Bellows Pump Model: CFD-8T-B. This pump is designed for use in metering strong acids, etc.

- (1) This instruction manual deals with the correct handling, maintenance and inspection, and troubleshooting methods for the pump. To ensure safe and efficient operation, please read this manual carefully before actually handling or operating the pump.
- (2) The use of this pump involves the handling of considerably dangerous liquids such as strong acids. Be sure to take adequate safety measures before operation.
- (3) The APD-3 type controller and other safety devices are used to operate this pump. Please read the respective instruction manuals carefully to ensure safe and efficient operation.

Contents

■ Item	■ Page
① Unpacking and Inspection.....	1
② Specifications.....	1
③ Handling Instructions.....	2
④ Installation, Piping, and Wiring.....	4
⑤ Operation, Adjustment, and Alarms.....	8
⑥ Maintenance and Inspection.....	11
⑦ Wear Parts.....	11
⑧ Troubleshooting Guide.....	12
⑨ Parts Description and Exploded View.....	13

1 Unpacking and Inspection



After unpacking the pump, check the following points to verify that the contents are exactly as you ordered. If you find any discrepancy, please contact your dealer.

- (1) Does the model on the nameplate conform to your order?
- (2) Has the pump been damaged in transit?

2 Specifications

■ Pump Specifications

Specifications		CFD-8T-B Type	
General specifications	Discharge	mℓ	8
	Max. pressure	MPa (PSi)	0.05 (7.11)
	Max. stroke	spm	30
	Supply air pressure	MPa (PSi)	0.15~0.3 (21.3~43)
	Temperature range of liquid handled	°F (°C)	68~140 (20~60)
	Air consumption	Nℓ/shot	0.18
	Liquid end material		PTFE, PFA
	Pump connection port diameter		1/4" tube (ø6.34×ø4.35mm)
	Supply air connection port diameter		M5
	Mass	kg (1b)	1.5 (3.3)
Sensor specifications	Type		Transmission type photo microsensor
	Power source voltage		DC5V
	Output current		Max. 50mA
	Length of lead wire		5m (PVC multicore cable, 4 cores of 6.5mm ²) with round terminal

3 Handling Instructions

External Dimensions

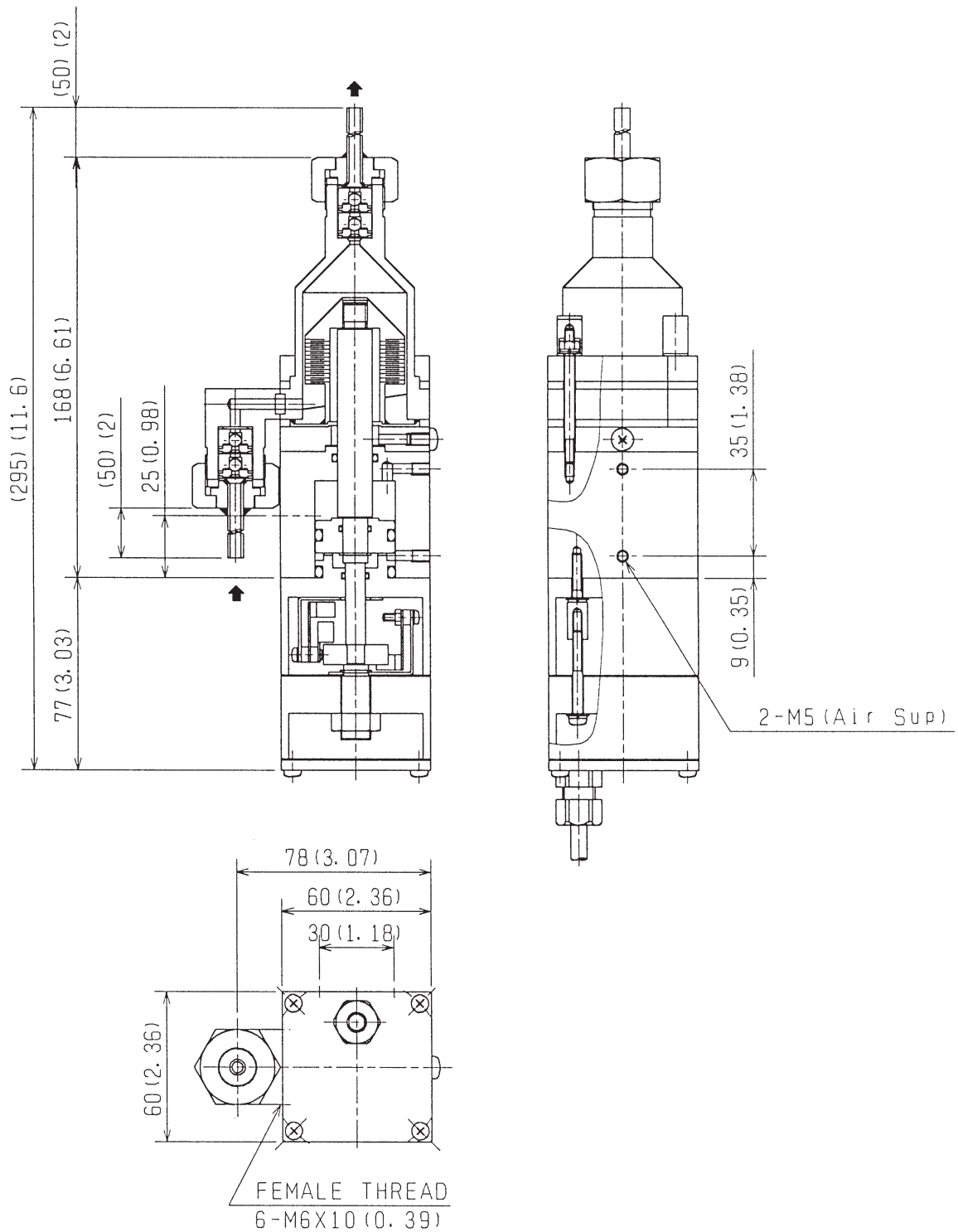

-
- (1) Use this pump together with the APD-3 type controller.
 - (2) Prepare the solenoid valve, which changes air direction to operate the pump, and regulator to keep steady air pressure.
 - (3) Never operate the pump with the discharge side closed. This will raise the pressure in the pump excessively, resulting in faulty operation.
 - (4) Handle the photo sensor lead wire carefully. Note that forcibly twisting the cord during the wiring process or readjusting on site may result in damage or poor connection in the soldered section for the inner element and the cord.

**DANGER**

When using a liquid that could injure workers or damage machinery in the vicinity, take appropriate protective measures against possible pump malfunctioning. Never fail to carry out daily and other periodic inspections.

**CAUTION**

To prevent malfunctioning due to a mixture of water, oil, dust, etc., use humidity- and dust-free, clean instrumentation air as the air supply.

**CAUTION**

If pump operation is suspended for a long period (more than one week), remove all chemicals from inside of the pump and fill with pure water. Some chemicals (HCl etc) can penetrate the PTFE bellows and metallic shafts can be corroded, if chemicals stay inside of the pump while pump operation is suspended for a long period. As a result, pump operation would be damaged.

4 Installation, Piping, and Wiring

Installation

- (1) Install the pump as close to the liquid tank as possible.
- (2) Orient the discharge port upward and the suction port downward, and make sure the bellows in the pump moves up and down. If the pump is not positioned vertically, its performance will be affected.
- (3) Use M6 screws to mount the pump firmly.

Connection

Carry out the connection of the pump, air-operated valves, and controller in accordance with the Basic Connection Diagram.

Basic Connection Diagram

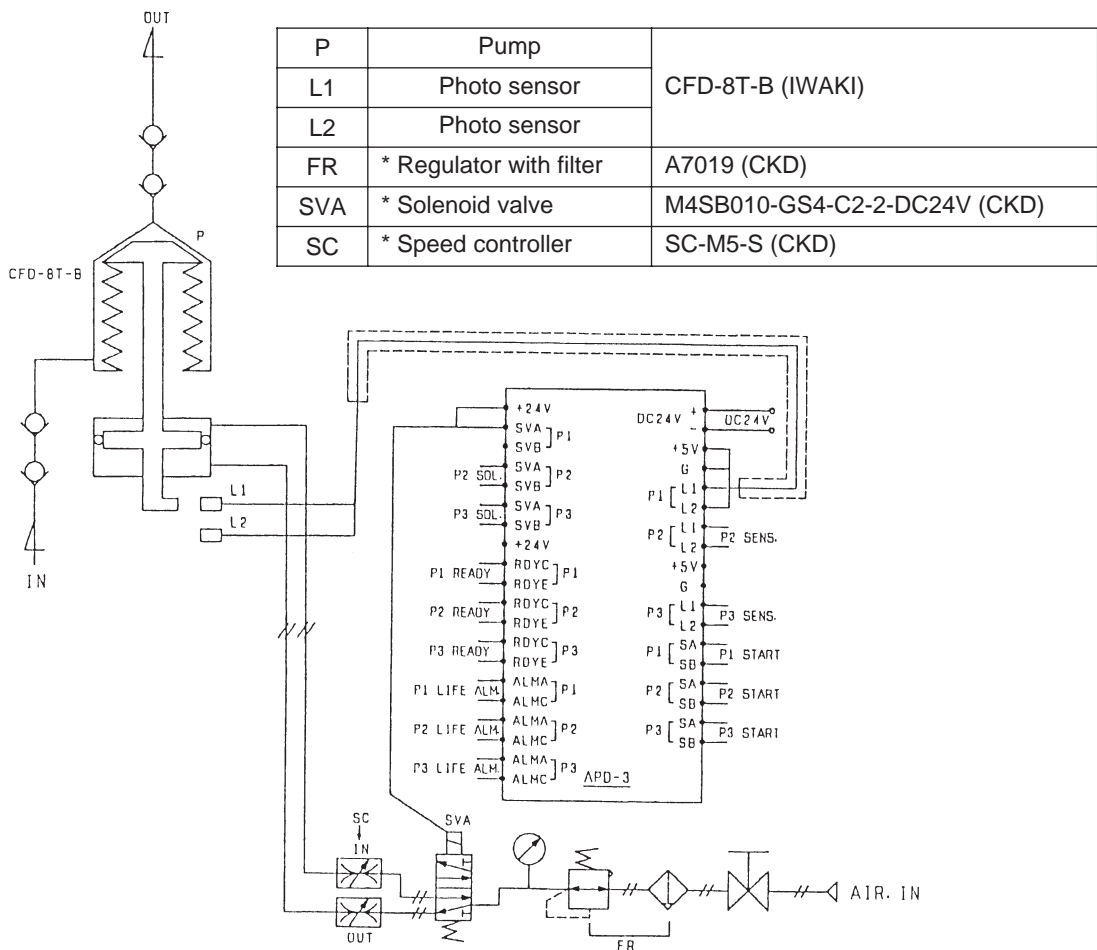

Note

* The user should prepare the regulator with filter, solenoid valve, and speed controller. The model and maker are given here as examples. If you use products by any other manufacturer, please select the respective equivalent items.

■ Pump Piping

PFA tubes are used for the standard discharge and suction ports. Observe the following piping procedures.

- (1) Joints available in the market may be used. However, select those that assure a leakproof connection, considering corrosion resistance and the pressure of the operating liquid.
- (2) The joints must be fastened firmly so that no air suction or liquid leakage can occur.
- (3) The piping must be as short as possible. In addition, the number of bends, joints, cocks, and solenoid valves that increase piping resistance must be kept to a minimum.
- (4) The diameter of the pipe must be larger than that of the pump discharge and suction ports.
- (5) In case of self-priming application

Recommended flow chart

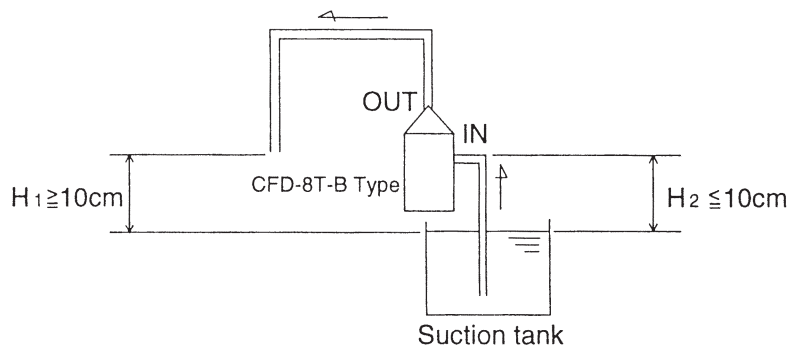

- a) Minimum differential height between discharge end and liquid level at suction tank (H_1) must be 10cm or more.
- b) Differential height between pump and liquid level at suction tank (H_2) should be kept within 10cm. If this value is too big, some chemicals create bubbles by their property and liquid temperature condition. And this decreases pump performance. For detail, please contact IWAKI.

(6) In case of flooded suction

Example of flooded suction

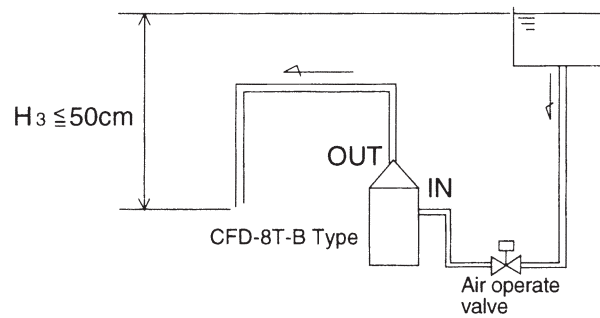

In case the end of discharge port is below the tank level, siphon phenomenon happens.

This pump is equipped with anti-siphon mechanism but attention must be paid to:

- a) When the pump is stopped, the air must be supplied and kept to the direction of discharge.
- b) The distance between the end discharge port and the tank level must be kept within 50cm. If it exceeds 50cm, flow rate increases and discharge accuracy goes down, also the leakage can not be avoided while pump is stopped.

*50cm is value for clear water ($\delta=1.0$)

When high specific gravity liquid is handled, value is changed. In order to get value, please use following formula. Max. differential height=50/specific gravity (cm)

- c) Pump speed must be fixed between 30 - 20spm. If the speed is slower than 20spm, discharge flows increases thus accuracy goes down.
- d) When the pump is stopped more than 24hours, a slight leakage happens. To avoid any leakage, air-operated valve must be installed at suction side piping.

■ Air piping

Use M5 thread for connecting the pipe to the pump air supply port. Observe the following piping procedures.

- (1) Use a $\phi 6 \times \phi 4$ mm tube to connect the air pipe with air instruments.
- (2) Carry out sufficient flushing inside the pipe to eliminate rust, burrs, and other foreign matter prior to installation.
- (3) Use humidity- and dust-free, clean instrumentation air as the air supply.
- (4) Extend the pipe from the secondary side of the regulating valve to the "P" port of the solenoid valve.
- (5) Connect the pump (CFD-8T-B) and the solenoid valve by connecting OUT with "A" port and IN with "B" port on the solenoid valve and the pump.

** Refer to the 'APD-3 Type Controller Instruction Manual' for details.*

■ Electrical Wiring

Faulty wiring may cause failure or malfunctioning of the photo sensor built into the pump or controller.

- (1) Connection with power source
Connect a power source of DC 24V $\pm 10\%$ with the DC 24V (+, -) terminals.
- (2) Connection with lead wire
Connect the pump lead wires (+5V, G, L1, L2) of the pump with the IN (+5V, G, L1, L2) terminals respectively.
- (3) Connection with external control systems
Connect each system with each terminal on the controller, such as LIFE ALM (ALMA ALMC), READY (RDYC, RDYE), and START (SA, SB).

Note: *Refer to the 'APD-3 Type Controller Instruction Manual' for details.*

5 Operation, Adjustment, and Alarms

■ Operation

- (1) Supply power (DC 24V \pm 10%) to the APD-3 type controller.
- (2) Set the pressure at 0.2 to 0.3 MPa {2 to 3 kgf/cm²} (28 to 43 PSi) by adjusting the regulating valve on the air pipe.
- (3) Fully rotate the speed controller clockwise on air piping.
- (4) Set the ON LINE/OFF LINE selector switch to 'OFF LINE' and press the MANU. START button. The pump operates only for the set shot number and then stops. Adjust the action speed of the pump by setting the speed controller.
- (5) Set the ON LINE/OFF LINE selector switch to 'ON LINE' when activating the pump via the external input method. When the start signal has been input, the pump starts operation.

■ Adjustment of Discharge

The discharge is controlled by a dual system, i.e.; adjustment of the number of strokes through the APD-3 type controller and adjustment of the length of stroke through the built-in adjusting screw of the pump itself.

[1] Method of Control

The number of strokes is adjusted by the speed controller on air piping in a range from 0 to 30 spm. As the pump is set at 8 mℓ/shot by the factory, this means that the discharge can be controlled in a range from 0 to about 240 mℓ/min.

○ Adjustment of the length of stroke

This method is used to change the range of discharges (i.e., to increase or decrease the discharge per shot). The length of stroke is adjusted by means of the control screw provided in the pump. For this adjustment, the pump should not be operating. It must be stopped.

Range of adjustment (guideline) : 7~10mℓ (Set at 8mℓ by factory)

<Control screw>

The control screw is turned by the use of a minus driver. (The length of stroke is changed by 1mm when the screw is rotated to make a full turn.)

Range of adjustment: 0~about 5 turns (0~5mm in stroke length)

- ▶ Turn to the right (clockwise) decreases the stroke length to reduce the discharge.
- ▶ Turn to the left (counterclockwise) increases the stroke length to raise the discharge.

※ When accurate adjustment is intended, do it while measuring the discharge per shot.

○ Adjustment of the number of strokes

For adjusting the number of strokes, the APD-3 controller is used.

※ For the procedure of this adjustment, see the instruction manual of the Model APD-3 Controller.

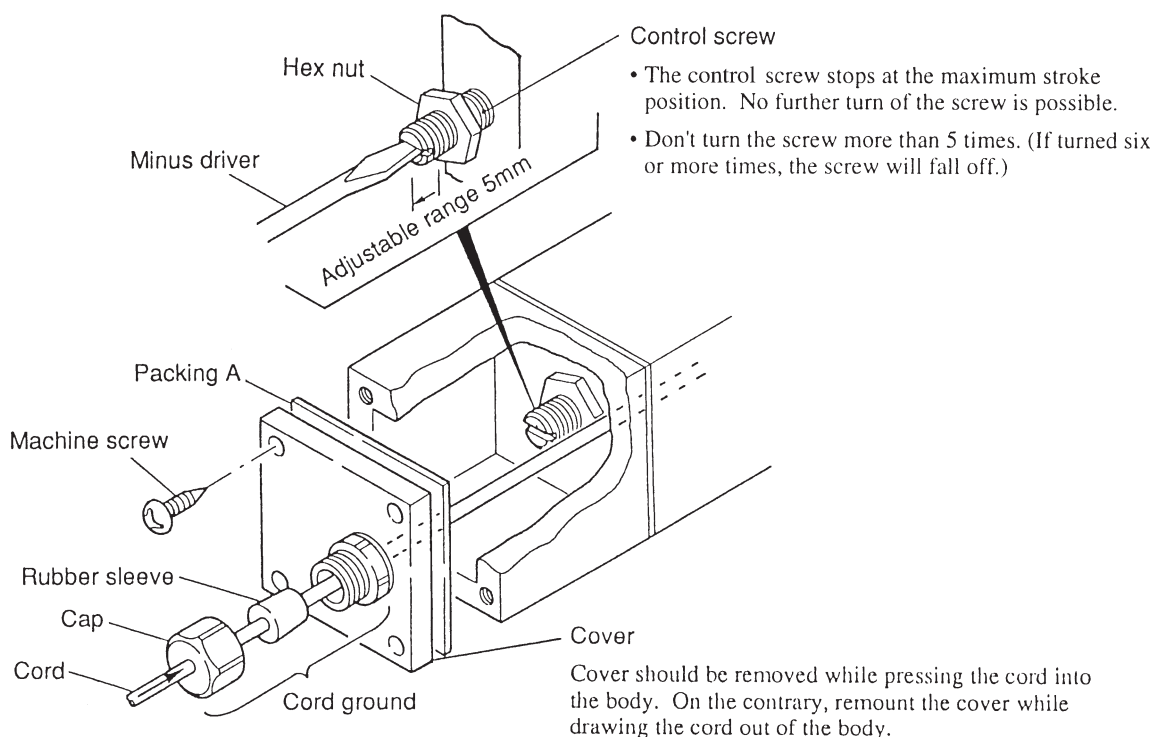

[2] Procedure for Adjusting Stroke Length

To adjust the stroke length, stop the pump and follow the steps described below, referring to the exploded view on page 13 "Structure of Pump and Names of Parts".

- ① Detach the small machine screw (45) from the pump body and remove the cover (10).
 - The cord is fixed to the cord ground. Undo the cap and pull the rubber sleeve out.
 - Remove the cover while pressing the cord into the body.
- ② Hold a minus driver to the control screw (41) and loosen the hex nut (42).
 - The pump is set at 8mℓ/shot by the factory. Use this position of the screw as your reference (guideline).
- ③ Adjust the length of stroke.
 - If the reference position of the screw driver is not clear, turn it to the leftmost position first. The stroke length is adjustable up to 5 turns (5mm).
 - For a more accurate setting, measure the discharge per shot. The pump should be put out of operation during adjustment and should be activated only when you measure the discharge.
- ④ Upon completion of adjustment, tighten hex nut (42) and reattach the cover (10).
 - Tighten the hex nut while fixing the control screw lest the latter should get out of position.
 - When you attach the cover, take care not to allow packing A (11) to project or twist.

■ Alarms

(1) Life alarm

If the pump operation reaches the set total count (the number of strokes representing the pump service life), the LIFE ALARM LED (red) on the APD-3 controller turns on and the pump stops. At the same time, an alarm is generated.



CAUTION After inspecting the pump, air-operated valve, etc., replace worn components and reset the controller.

Note: Refer to the 'APD-3 Type Controller Instruction Manual' for the resetting procedure.

⑥ **Maintenance and Inspection**

■ Daily Inspection

Verify that the pump operates normally and that the following points are all satisfied.

- (1) The sealed sections of the air piping have no leakage.
- (2) The supply air is clean.
- (3) The air pressure is at a normal level.
- (4) The supply air amount is at a normal level.
- (5) No liquid leakage is detected.

⑦ **Wear Parts**

No.	Part Name	Qty.	Remarks	Replacement Period
2	Bellows	1		1 yr.
19	O ring	1	P-8	
20	O ring	1	P-10	
21	O ring	1	P-14	
22	O ring	2	P-26	
52	VALVE GASKET	10		
54	VALVE	4	3/16"	
55	VALVE SEAT	4		

Note 1. *The number of parts indicated is for a single pump.*

Note 2. *The replacement period is for reference, not a guaranteed period.*

Note 3. *The durability of the expendable parts depends upon the temperature, pressure, and characteristics of the applied liquid. The replacement period is a guideline.*

8 Troubleshooting Guide

Problem	Causes	Countermeasures
Pump does not start.	Faulty setting of photo sensor Bellows is damaged. (Alarm output) Supply air pressure or amount is lowered. <ul style="list-style-type: none"> • Compressor is out of order. • Pressure set for reducing valve is insufficient. • Air filter, etc., is clogged. • Air leaks from pipe. • Speed controller is set to excessively low speed. • Switching action of solenoid valve is affected. Controller is out of order. <ul style="list-style-type: none"> • Faulty wiring or disconnection Faulty wiring Faulty piping	Reset or replace photo sensor. Replace pump. Inspect and repair compressor. Set pressure correctly. Clean or replace element. Repair pipe. Readjust controller. Inspect, repair, or replace valve. Inspect, repair, or replace valve. Inspect and set up normal wiring. Inspect and set up normal piping.
Pump starts but does not discharge liquid.	Valve is clogged with foreign matter. Air enters via suction pipe.	Inspect, clean, or repair valve. Further tighten pipe joints.
Discharge volume is reduced.	Supply air pressure or amount is lowered. Valve is clogged with foreign matter. NPSHa is insufficient. Discharge pressure is raised. O ring in drive section is worn out.	See 'Pump does not start' column. Inspect, clean, repair, or replace valve. Check suction condition and take necessary measures. Check discharge condition and take necessary measures. Inspect and replace O ring.

9 Parts Description and Exploded View

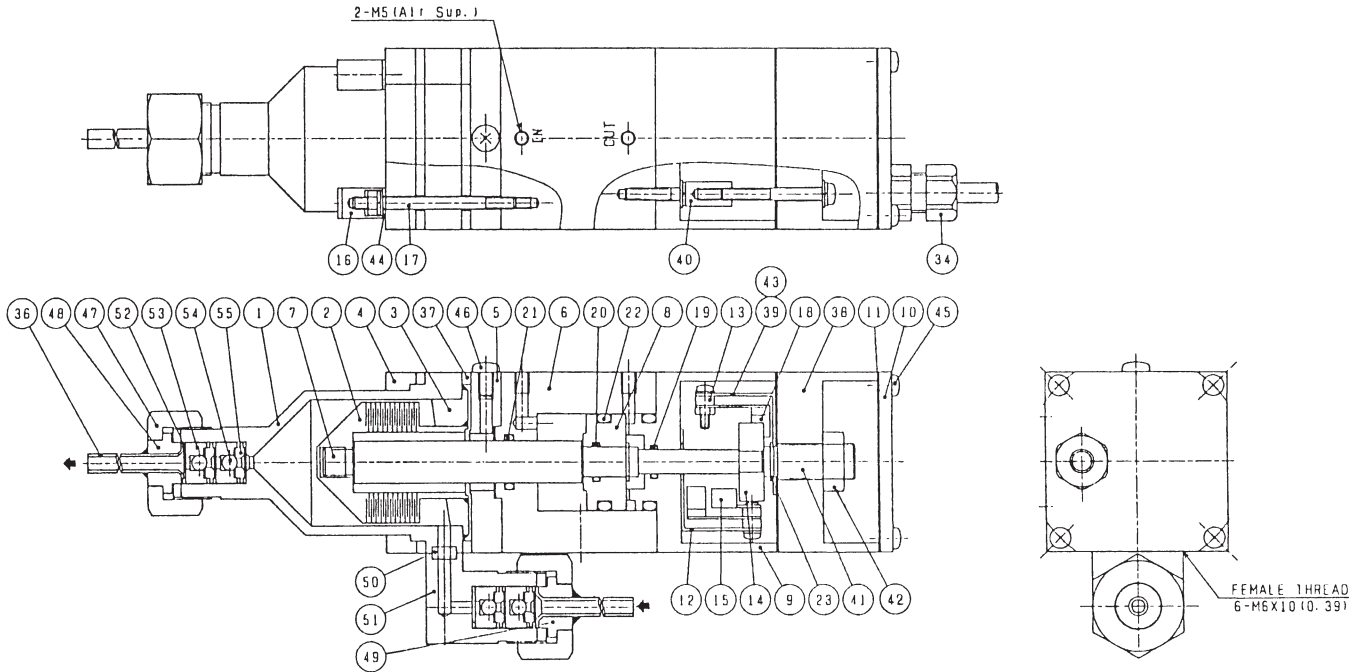

No.	Parts Name	Q'ty	Material	Remarks
1	PUMP HEAD	1	PTFE	
2	BELLOWS	1	PTFE	
3	BELLOWS RING	1	PTFE	
4	FLANGE A	1	PVC	
5	FLANGE B	1	PVC	
6	CYLINDER	1	PVC	
7	PISTON ROD	1	SUS304	
8	PISTON	1	POM	
9	CYLINDER COVER	1	PVC	
10	COVER	1	PVC	
11	PACKING A	2	SILICON RUBBER	
12	INSTALLED BASE A	1	SUS304	
13	SPACER	3	PVC	
14	GUIDE PLATE	1	PVC	
15	GUIDE	1	SUS304	
16	NUT A	4	PVC	
17	STUD BOLT	4	SUS304	
18	SENSOR	2		
19	O RING	1	FKM	P-8
20	O RING	1	FKM	P-10
21	O RING	1	FKM	P-14
22	O RING	2	FKM	P-26

No.	Parts Name	Q'ty	Material	Remarks
23	STOP RING	2	SUS304	S-10
34	CORD GROUND	1	PP	SCL-6B
36	TUBE	2	PFA	1/4B
37	PACKING B	2	SILICON RUBBER	
38	CONTROL CASE	1	PVC	
39	INSTALLED BASE B	1	SUS304	
40	FIXED BOLT	4	SUS304	
41	CONTROL SCREW	1	SUS304	
42	HEX NUT	1	SUS304	
43	SPRING PIN	1	SUS304	
44	GASKET	4	PTFE	
45	SCREW	4	POLYCARBONATE	M4×8
46	SCREW	1	POLYCARBONATE	M5×8
47	VALVE CAP	2	PP	
48	DISCHARGE PORT	1	PTFE	
49	SUCTION PORT	1	PTFE	
50	GASKET A	1	PTFE	
51	VALVE CASE	1	PTFE	
52	VALVE GASKET	10	PTFE	
53	VALVE GUIDE	4	PTFE	
54	VALVE	4	PTFE	3/16
55	VALVE SEAT	4	PTFE	



IWAKI CO.,LTD. 6-6 Kanda-Sudacho 2-chome Chiyoda-ku Tokyo 101-8558 Japan
 TEL:(81)3 3254 2935 FAX:3 3252 8892(<http://www.iwaki-pumps.co.jp/>)

()Country codes

Germany	: IWAKI EUROPE GmbH	TEL: (49)2154 9254 0 FAX:2154 1028	Singapore	: IWAKI Singapore Pte. Ltd.	TEL: (65)763 2744 FAX:763 2372
Italy	: IWAKI Italia S.R.L.	TEL: (39)02 9903931 FAX:02 99042888	Indonesia	: IWAKI Singapore (Indonesia Branch)	TEL: (62)21 392 8288 FAX:21 392 8088
Denmark	: IWAKI Pumper A/S	TEL: (45)48 24 2345 FAX:48 24 2346	Malaysia	: IWAKIm Sdn. Bhd	TEL: (60)3 703 8807 FAX:3 703 4800
France	: IWAKI France S.A.	TEL: (33)1 69 63 33 70 FAX:1 64 49 92 73	Taiwan	: IWAKI Pumps Taiwan Co.,Ltd.	TEL: (886)2 2776 5900 FAX:2 2740 2812
Switzerland	: IWAKI (Schweiz) AG	TEL: (41)32 3235024 FAX:32 3226084	Thailand	: IWAKI (Thailand) Co.,Ltd.	TEL: (66)2 322 2471 FAX:2 322 2477
U.K.	: IWAKI PUMPS (UK) LTD	TEL: (44)1743 231363 FAX:1743 366507	Hong Kong	: IWAKI Pumps Co.,Ltd.	TEL: (852)2 607 1168 FAX:2 607 1000
Sweden	: IWAKI Sverige AB	TEL: (46)8 511 72900 FAX:8 511 72922	China	: IWAKI Pumps Co.,Ltd. (Shanghai office)	TEL: (86)21 5234 0776 FAX:21 5234 0775
Finland	: IWAKI Suomi Oy	TEL: (358)9 2742714 FAX:9 2742715	China	: IWAKI Pumps Co.,Ltd. (Beijing office)	TEL: (86)10 6442 7713 FAX:10 6642 7712
Austria	: IWAKI (Austria) GmbH	TEL: (43)2236 33469 FAX:2236 33469	China	: IWAKI Pumps Co.,Ltd. (Guangzhou office)	TEL: (86)20 8130 0605 FAX:(86)20 8130 0601
Norway	: IWAKI Norge AS	TEL: (47)66 80 66 86 FAX:66 80 66 87	Australia	: IWAKI Pumps Australia Pty. Ltd.	TEL: (61)2 9899 2411 FAX:2 9899 2421
Holland	: IWAKI Holland B.V.	TEL: (31)297 241121 FAX:297 273902	U.S.A.	: IWAKI WALCHEM Corporation	TEL: (1)508 429 1440 FAX:508 429 13864
Spain	: IWAKI Iberica Pumps,S.A.	TEL: (34)943 630030 FAX:943 628799			
Belgium	: IWAKI Belgium n.v.	TEL: (32)1430 7007 FAX:1430 7008			