

IWAKI Magnetic Drive Pump

Model MDH-(F)

Instruction Manual (Asian Edition)

 Read this manual before use of product

This product is protected by patent.

Thank you for selecting the Iwaki Magnetic Drive Pump type MDH, MDH-F. This instruction manual has been prepared to ensure correct and safe handling of the pump. Please read this manual carefully and thoroughly prior to operating the pump. Pay special attention to the "Safety Instruction to Prevent Personal Injuries," "Warning," and "Caution" messages included in this manual. This instruction manual should be kept by each end user and within reach of the actual operator, for quick reference when needed.

Contents

IMPORTANT INSTRUCTIONS	1~5
Safety Instructions to Prevent Personal Injuries	
OUTLINE OF PRODUCT	6~14
1. Before Using Pump	7
2. Operating Principle	7
3. Identification Codes	8
4. Specifications and Outer Dimensions	9
5. Names of Parts	12
PUMP OPERATION	15~29
1. Handling Instructions	16
2. Installation	20
3. Piping	21
4. Wiring	25
5. Operation Step	26
MAINTENANCE	30~43
1. Causes of Trouble and Troubleshooting	31
2. Maintenance and Inspection	34
3. Spare Parts	38
4. Disassembly and Assembly	39



Please contact the Iwaki sales office or Iwaki dealer for any inquiries or questions regarding this product.

IMPORTANT INSTRUCTIONS

Important notes and statements for safe operation, preventing physical injury, and property damage, are included on the body of the product and in the attached instruction manual.

Always Observe These Safety Instructions!

Safety Instruction to Prevent Personal Injuries

 Warning	Ignoring this message can lead to improper handling resulting in death or serious injury to the operator.
 Caution	Ignoring this message can lead to improper handling resulting in injury to the operator or damage to the product.

Safety Section

WARNING

- **Damaged or deteriorated tools are very dangerous.** Use qualified and suitable tools only.
- **Use of protectors:** When disassembling, assembling, and conducting maintenance or when handling a dangerous type of liquid or a liquid of unknown property, be sure to wear safety gloves, a helmet, and protective shoes. In addition, when handling wet-end parts, always wear protective goggles, masks, etc.
- **To prevent death or injury from a falling pump,** make sure the rope or chain used for lifting the pump is not accidentally cut or disconnected during installation. Make sure the rope or the chain used to lift the pump has sufficient strength in relation to the pump load. Also, be sure not to stand underneath a lifted or suspended pump.
- **When fixing the pump with rope or chain,** be sure to use special bolts (or rings) for lifting. Never use any other points for lifting the pump.
- **Always turn off the power supply prior to servicing the pump.** Make special provisions so that no other operator mistakenly turns on the power supply while someone is working on the pump. In a noisy or poor visibility environment, display a sign near the power supply switch to notify others that someone is "WORKING" on the pump. Power supply mistakenly turned on during maintenance may lead to personal injury. Each operator must be especially careful of power supply operation.
- **To ensure greater safety, check and make sure that there is no one near the pump when switching on the power supply.** The pump is not equipped with an ON/OFF switch. Connecting the power cable supplies the power to the pump and starts the operation.
- **Run the pump at the specified power supply voltage on the nameplate only.** Otherwise, fire or electric shock may result.
- **If the pump operation is stopped due to a power failure or closure of discharge wire,** turn off the power switch at once. After normal conditions return, turn the switch on again.
- **Do not use the pump for anything that it is not designed to do.** User's failure to observe this instruction exempts Iwaki from any responsibility for personal injury or damage to the equipment or facility caused by the pump's misuse.
- **When handling a toxic or odorant liquid,** ventilate the working area well. In addition, the operator must wear protector gear (such as a safety mask, safety goggles, and protective gloves).



Safety Section

WARNING

- **Do not allow toxic substances such as lubricants, solvents, or similar substances to flow into the local sewage system or river systems.**

Do not drain hazardous liquids such as chemical solutions discharged out of the pump directly onto the ground. Instead, drain such liquids into some kind of container. Observe the laws and regulations related to the application, handling, and processing of hazardous substances.



Prohibited

- **Do not pass under a raised pump**

Never pass under a raised pump. A serious injury could occur if the pump is accidentally dropped.



- **No remodeling**

Remodeling of the pump by the user may result in serious personal injury, electric shock, or damage to the pump. Do not attempt remodeling as it is very dangerous.



No Remodeling

- **Cautions when dangerous liquids are transferred.**

When the pumps are used to transfer the dangerous liquids mentioned as below, the pumps always must be checked and watched so that the liquids can not be leaked. The operation of the pumps leaking the liquids may result in personal injury and/or explosion, fire accidents.



- Explosive, fire-spreading and inflammable liquids
- Corrosive and stimulus toxic liquids
- Liquids detrimental to health

CAUTION

- **Qualified operators only**

The pump operator and pump operation supervisor must not allow any operators who have little or no knowledge of the pump to run operate the pump. Pump operators must have a sound knowledge of the pump and its operation.



- **For specified application only**

The pump is designed and manufactured to the specifications agreed upon by the user and Iwaki. The use of a pump in any application other than those clearly specified may result in injury or damage to the pump. Use the pump strictly in accordance with the pump specifications and application range. If you change any specification, contact Iwaki or your dealer.



Prohibited

- **Ventilate**

Poisoning may result during an operation which involves toxic or odorous liquid. Ventilate the operating site sufficiently.



Caution

Safety Section

CAUTION

- **Spill-out prevention measures**

Appropriate protective measures should be taken against any spill-out accidents involving the operating liquid as a result of unexpected damage to the pump or the piping. Never discharge hazardous liquid, including, but not limited to, chemical liquid, over the ground or floor on the pump operating site. Follow local rules and regulations in disposing of hazardous substances.



- **Do not operate the pump dry.**

Do not run the pump dry (without liquid inside the pump). Heat generated as a result of abrasion between elements inside the pump during operation without liquid may damage the inside of the pump. Operating the pump with the suction valve fully closed will result in dry operation.



- **Keep away from heat or flame.**

Do not place any open flame or flammable object near the pump.



- **Do not stand on the pump.**

Do not stand on the pump or use the pump as a step under any circumstances. Otherwise, you may experience a serious injury.



- **Do not touch the pump.**

When the pump is used to feed a hot liquid, do not touch the pump or the piping with your bare hands during and immediately after operation as their surfaces are dangerously hot.



- **Arrange grounding**

Do not operate the pump without connecting the grounding wire. Otherwise, an electrical shock may result. Make sure the grounding wire is connected with the grounding terminal.



- **Install an earth leakage breaker**

The operation of a pump without using an earth leakage breaker may cause an electrical shock. Please install an optional leakage breaker in the system.

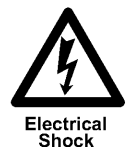

- **Do not install or store the pump in the following places.**

- Places where flammable gas, dust or material is used or placed.
- Places where corrosive gas (chlorine gas or the like) is generated.
- Places where the ambient temperature is extremely high (40 °C or higher) or extremely low, 0 °C or lower.
- Places where the pump is exposed to extreme dust or humidity. (Excluding the outdoor type)
- Places where vibrations occur.



Safety Section

CAUTION

- **Pump start-up**

When connecting a power supply to the pump, make sure there is no person around the pump. The pump has no ON/OFF switch. The pump starts operation when the power is supplied by connecting the power supply cable.



- **Foreign matter**

Should foreign matter enter the pump, turn off the power at once and remove the obstruction. Using the pump with foreign matter inside may cause damage to the pump or a malfunction.



- **Disposal of used pump**

Disposal of used or damaged pumps must be done in accordance with local laws and regulations. (Consult a licensed industrial waste products disposing company.)



- **Handling of magnet coupling**

The magnet used in the pump has a very high magnetic power. Be careful not to allow your fingers to be seized by the magnet or to allow the magnet near any electronic device which may be affected by the magnet's power.



- **Suspending pump operation for a prolonged period**

When suspending pump operation for a prolonged period, drain the pump and clean inside the pump. Take appropriate measures to prevent the entrance of foreign matter into the pump. If the pump is not operated for a period longer than one year, replace the O ring and inspect inside the pump.



- **Countermeasure for static electricity**

When low electric conductivity liquid such as ultra-pure water and fluor inactive liquid(e.g.Fluorinert™) are handled, the static electricity may be generated in pump, which may cause static discharge and break down. Take countermeasure to avoid and remove static electricity.



OUTLINE OF PRODUCT

1. <i>Before Using Pump</i>	7
2. <i>Operating Principle</i>	7
3. <i>Identification Codes</i>	8
4. <i>Specifications and Outer Dimensions</i>	9
5. <i>Names of Parts</i>	12

1. Before Using Pump

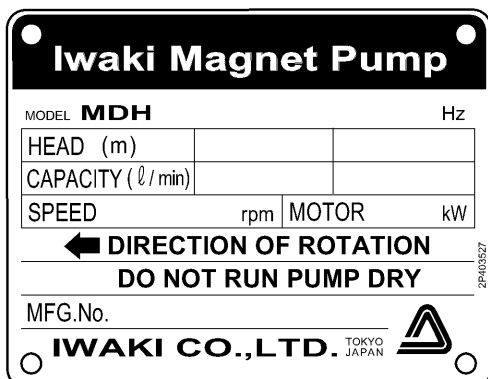

After unpacking, check the following points to confirm that the delivered product and its accompanying parts and elements are exactly what you ordered.

When lifting the pump please follow the procedure mentioned "2. Installation" of "Pump operation".

- [1] Do the model and frequency indicated on the nameplate conform to your order?
- [2] Has the pump unit or any part of it been damaged or have bolts and nuts been loosened during delivery?
- [3] Prior to the installation of the MDH-(F)□KK pump (using SiC parts), remove the cardboard pad inserted inside the suction port.
- [4] The third numeral of MFG.No. shows the year the product was manufactured.
(e.g.) xx5xxx
"5" shows the product was manufactured in the year 1995.

If you find anything wrong, please refer to the dealer you placed your order with.

2. Operating Principle

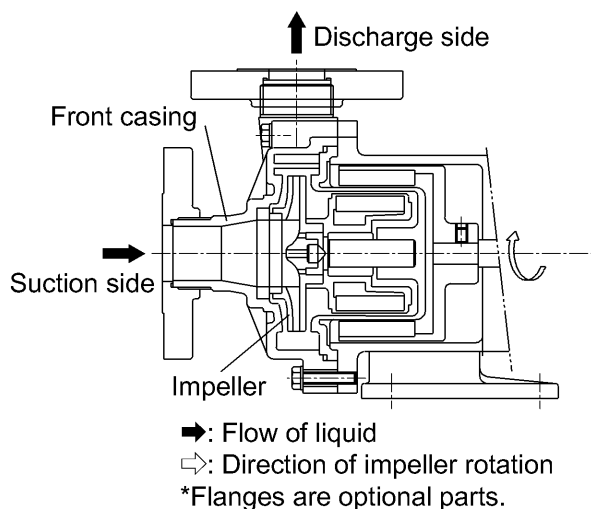

The MDH-(F) pump is a magnet-driven centrifugal type pump developed for various applications. The impeller inside the pump chamber (front casing) is rotated by magnetic force to transfer liquid from the suction side to the discharge side. The MDH-(F) type pump features excellent corrosion resistance, durability, and safety, and serves as a chemical pump for various processes. Most chemicals can be handled by the pump.

3. Identification Codes

Example:

<div style="text-align: center;"> <u>MDH - F 40 0 CV 5 C - D</u> ① ② ③ ④ ⑤ ⑥ ⑦ ⑧ </div>		
①	Series	MDH Type Series
②	Material of casing	No mark: GFRPP F: CFRETFE
③	Size of pump	Shows discharge port diameter. (42 shows 40mm)
④	Motor output	0: 0.4kW 1: 0.75kW 2: 1.5kW 3: 2.2kW 5: 3.7kW
⑤	Material of Bearing / Spindle / O ring	<div style="display: flex; justify-content: space-between;"> <div style="border-left: 1px solid black; border-right: 1px solid black; padding: 5px;"> CV: Carbon/Alumina ceramics/FKM RV: PTFE/Alumina ceramics/FKM FE: Carbon/High purity alumina ceramic </div> <div style="border-left: 1px solid black; border-right: 1px solid black; padding: 5px;"> MDH </div> </div> <div style="display: flex; justify-content: space-between;"> <div style="border-left: 1px solid black; border-right: 1px solid black; padding: 5px;"> CFV: High density carbon/ High purity alumina ceramics/FKM AAV: Alumina ceramics/Alumina ceramics/ FKM (For 400 and 401 types)/ High purity alumina ceramics/ High purity alumina ceramics/ FKM (For 422 and 423 types) </div> <div style="border-left: 1px solid black; border-right: 1px solid black; padding: 5px;"> MDH-F </div> </div>
⑥	Code of impeller	MDH: 5 (50Hz) / 6 (60Hz) MDH-F: T, V, W (50Hz) / X, Y, Z (60Hz)
⑦	Type of motor	No symbol : Totally enclosed fan cooled, indoor type C : Totally enclosed fan cooled, outdoor type
⑧	Construction code	D, E: Pin-point contacting bearing system

4. Specifications and Outer Dimensions

■ Standard specifications

Model	Port Connection inch (Port Diameter mm) Suction Port × Discharge Port	Impeller Code	Standard Performance m-l / min		Motor Output kW
			50Hz	60Hz	
MDH-400	G1 1/2 × G1 1/2 (40 × 40)	5/6	8.5 - 150	8.5 - 150	0.4
MDH-401		5/6	12 - 200	12.5 - 200	0.75
MDH-422	G2 × G1 1/2 (50 × 40)	5/6	18 - 200	17.5 - 200	1.5
MDH-423		5/6	20.5 - 300	19.5 - 300	2.2
MDH-425		5/6	25.5 - 400	26.5 - 400	3.7
MDH-F400	G1 1/2 × G1 1/2 (40 × 40)	T/X	8 - 150	7 - 150	0.4
		V/Y	6.5 - 150	5 - 150	
		W/Z	3.5 - 150	3 - 150	
MDH-F401		T/X	9.3 - 200	9.5 - 200	0.75
		V/Y	8 - 200	6.5 - 200	
		W/Z	5 - 200	3.5 - 200	
MDH-F422	G2 × G1 1/2 (50 × 40)	T/X	17 - 200	16.5 - 200	1.5
		V/Y	14 - 200	13 - 200	
		W/Z	10 - 200	9.5 - 200	
MDH-F433		T/X	19.5 - 300	19 - 300	2.2
		V/Y	15.5 - 300	14.5 - 300	
		W/Z	11.5 - 300	10.5 - 300	

■ Outer dimensions

· MDH-(F) 400 and 401

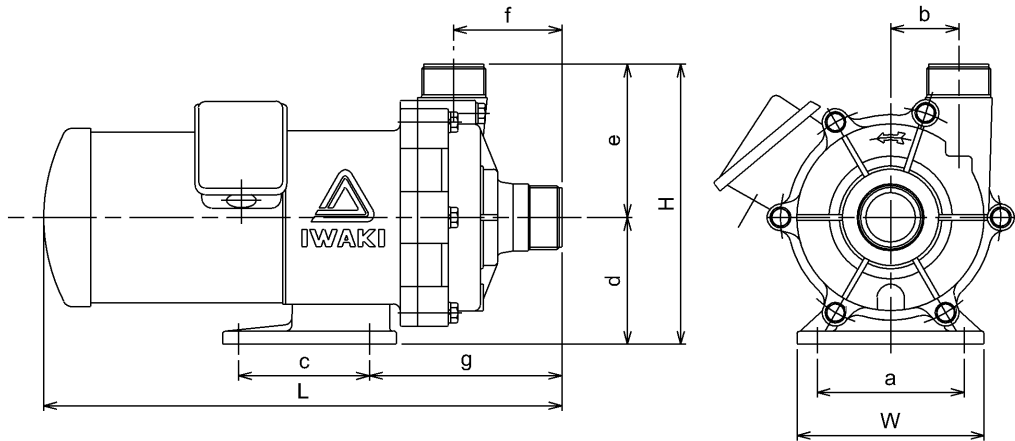

Model	W	H	L	a	b	c	d	e	f	g	i
MDH-(F) 400	140	210	388	110	51	98	95	115	81	144	φ12
MDH-(F) 401	160	248	488	130	57.5	130	115	133	96.5	178	φ12

· MDH-(F) 422 and 423

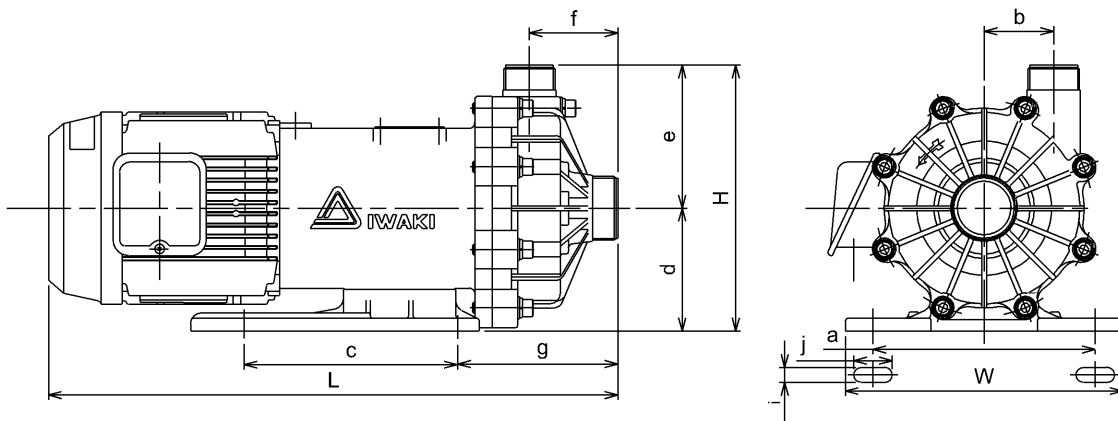

· MDH-(F) 425

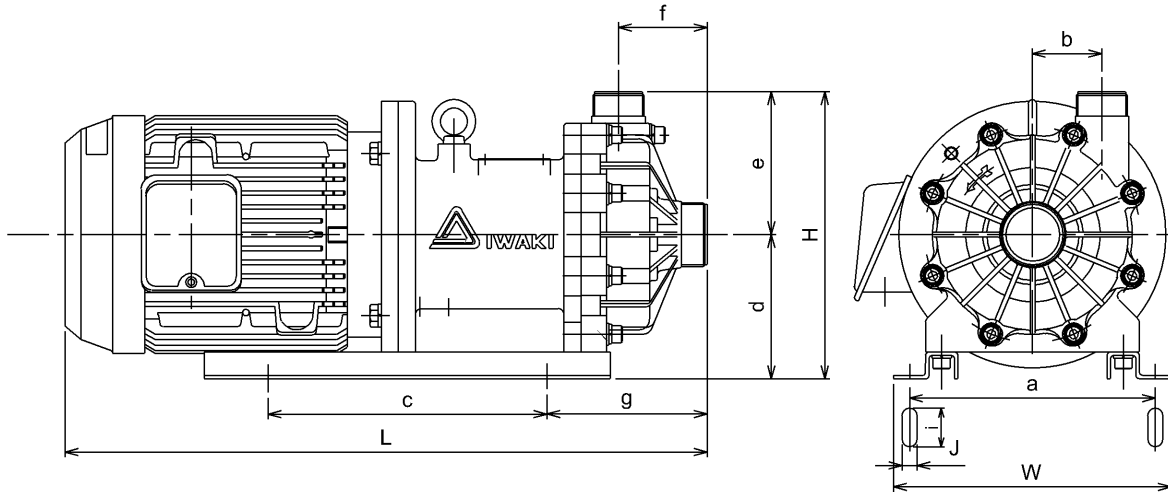

Model	W	H	L	a	b	c	d	e	f	g	i	j
MDH-(F) 422	260	249	533	208	65	200	115	134	83	150	14	36
MDH-(F) 423		269	601	230		261	135				36	14
MDH-425												

■ Mass

Model	400	401	422	423	425
MDH	14 kg	19 kg	31 kg	32 kg	50 kg
MDH-F	15 kg	20 kg	32 kg	33 kg	

5. Names of Parts

Names of Parts

- MDH-(F) 400 and 401

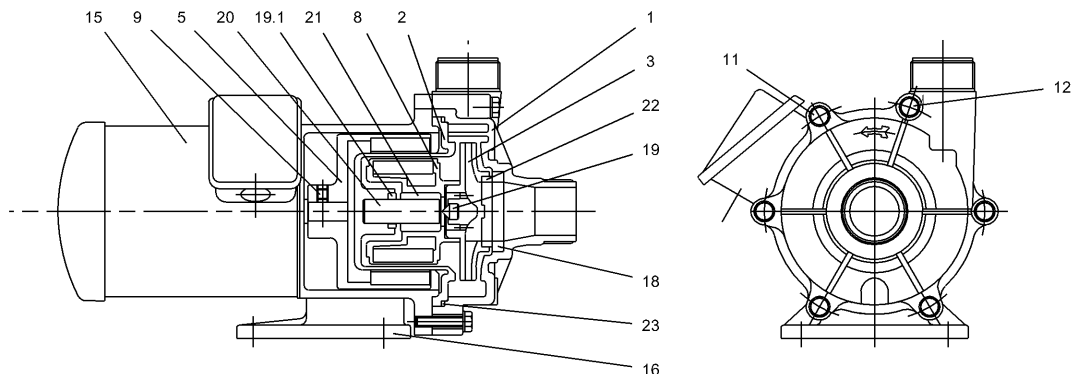

No.	Parts name	Q'ty	Material		Remarks	
			MDH	MDH-F	Model 400	Model 401
1	Front casing	1	GFRPP	CFRETFE		
2	Rear casing	1	GFRPP	CFRETFE		
3	Impeller	1	GFRPP	CFRETFE		
5	Drive magnet unit	1	FERRITE MAGNET+ ALUMINUM ALLOY			
8	Magnet capsule	1	PP	CFRETFE		
9	Hex. socket set screw	2	STEEL		M8 × 10	M8 × 10
11	Hex. head bolt		STNLS STL		M8 × 35, WITH PW, SW, Q'TY4	M8 × 40, WITH PW, SW, Q'TY6
12	Hex. head bolt		STNLS STL		M8 × 55, WITH PW, SW, Q'TY2	M8 × 65, WITH PW, SW, Q'TY2
15	Motor	1				
16	Base	1	GFRPP			
17	Adapter	1	FC200			

No.	Parts name	Q'ty	Material					Remarks			
			Model MDH		Model MDH-F			Model			
			CV-D	RV-E	FE-D	CFV-D	AAV-E	MDH 400	MDH-F 400	MDH- 401	MDH-F401
18	Liner ring	1	Alumina ceramic		High purity alumina ceramic	Alumina ceramic					
19	Impeller thrust	1	Alumina ceramic		Carbon	High purity alumina ceramic					
19.1	Rear thrust	1	High purity alumina ceramic								
20	Spindle	1	Alumina ceramic		High purity alumina ceramic	Alumina ceramic					
21	Bearing	1	Carbon	PTFE	Carbon	High density carbon	Alumina ceramic				
22	Mouth ring	1	PTFE								
23	O ring	1	FKM		EPDM	FKM		JIS B 2401 G135	AS568-252	JIS B 2401 G160	

• MDH-(F) 422 and 423

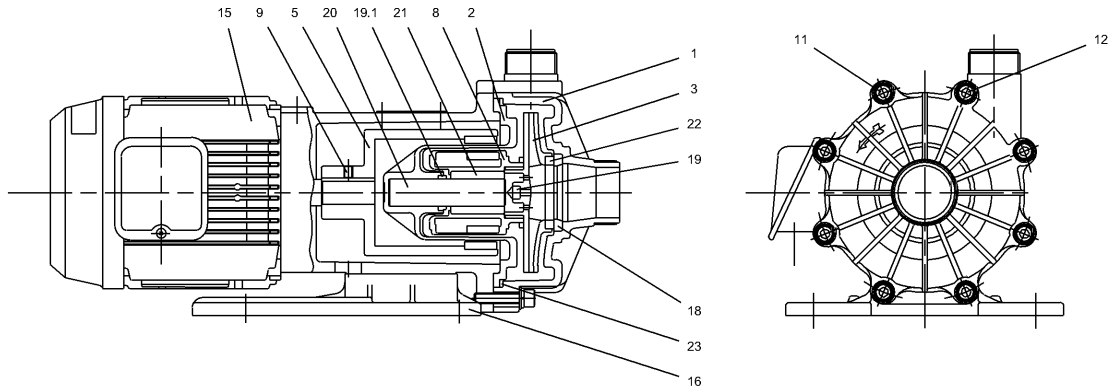

• MDH-425

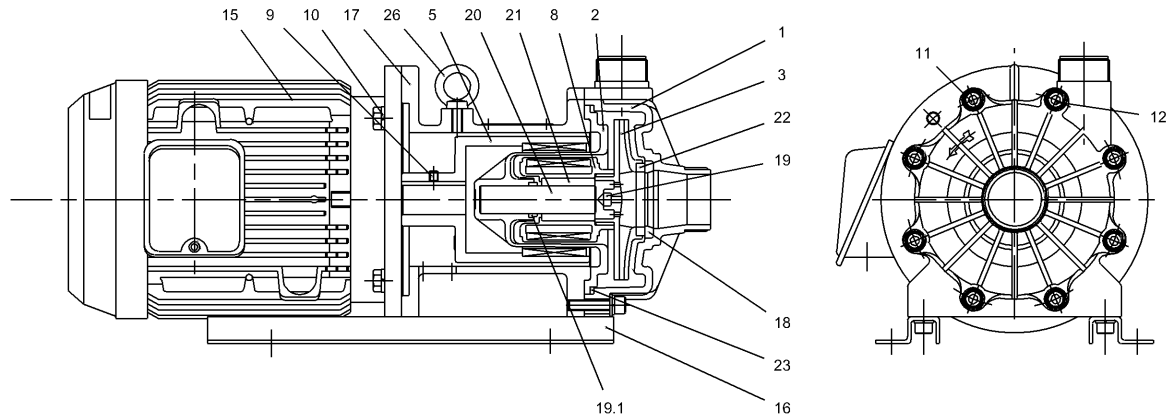

No.	Parts name	Q'ty	Material		Remarks
			Model MDH	Model MDH-F	
1	Front casing	1	GFRPP	CFRETFE	
2	Rear casing	1	GFRPP	CFRETFE	
3	Impeller	1	GFRPP	CFRETFE	
5	Drive magnet unit	1	RARE EARTH MAGNET + FCD450		
8	Magnet capsule	1	PP	CFRETFE	
9	Hex. socket set screw	2	STEEL		M8 × 10
11	Hex. socket head bolt	6	STNLS STL		M10 × 45 WITH PW, SW
12	Hex. socket head bolt	2	STNLS STL		M10 × 85 WITH PW, SW
15	Motor	1			
16	Base		422, 423:GFRPP, Q'ty 1	425:SPCC, Q'ty 2	
17	Adapter	1	FC200		Only model 425

No.	Parts name	Q'ty	Material					Remarks
			Model MDH			Model MDH-F		
			CV-D	RV-E	FE-D	CFV-D	AAV-E	
18	Liner ring	1	Alumina ceramic		High purity alumina ceramic	Alumina ceramic		
19	Impeller thrust	1			Carbon	High purity alumina ceramic		
19.1	Rear thrust	1	High purity alumina ceramic					
20	Spindle	1	Alumina ceramic		High purity alumina ceramic			
21	Bearing	1	Carbon	PTFE	Carbon	High density carbon		
22	Mouth ring	1	PTFE					
23	O ring	1	FKM		EPDM	FKM	JIS B2401 G165	

■ Description on Main Unit Body and Label

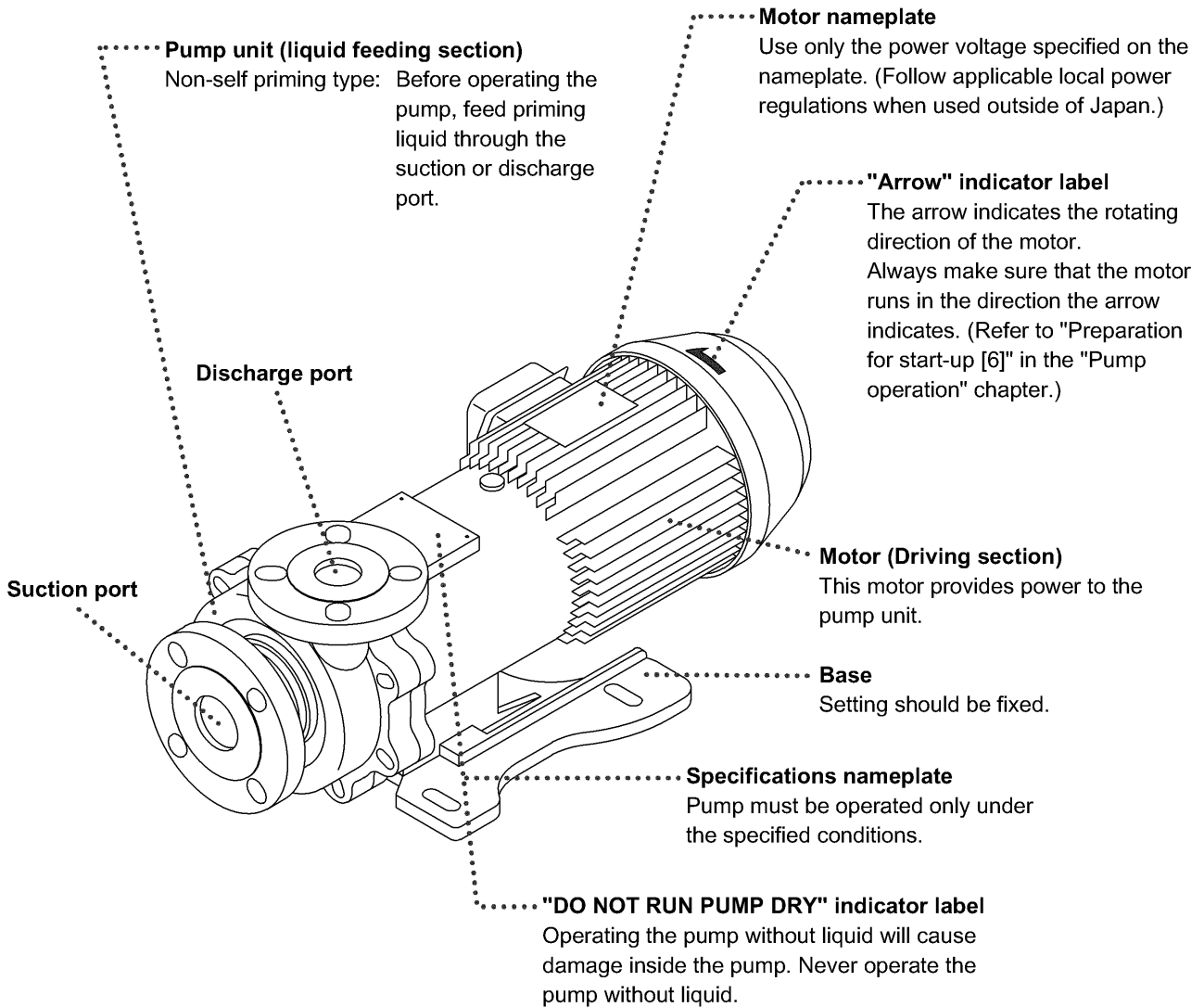

*Flanges are optional parts.

CAUTION

When cleaning the pump, be careful not to wipe the labels or the pump body with solvent.

PUMP OPERATION

1. <i>Handling Instructions</i>	16
2. <i>Installation</i>	20
3. <i>Piping</i>	21
4. <i>Wiring</i>	25
5. <i>Operation Step</i>	26

1. Handling Instructions

(Observe all the following instructions to prevent injuries and accidents.)



Caution

- **Read the following information prior to installing the pump.**
- **Protective wear:**
When operating the pump or working near it, with the pump system loaded with chemical liquid, always wear protective clothing, face guard, goggles, and gloves. Further precautionary measures must be taken depending upon the type of liquid used.
- **Operating the pump dry (without supplying liquid to it) may cause seizure on wear of the inside of the pump section.**
- **Do not repair the pump beyond the range specified in this instruction manual.**
The pump must be repaired by trained and qualified operators only.

[1] Handle the pump carefully.

A strong impacts caused by dropping the pump on the floor or striking it may result in damage or faulty performance.

[2] Priming water

Be sure to fill the pump unit with feeding liquid as priming water before pump operation.

[3] Do not operate the pump in the following places.

- Places where the temperature falls below 0 °C
- Places where corrosive gas or explosive gas (such as chlorine gas) is generated
- Places exposed to splashing water
- Places where the ambient temperature is 40 °C or above
- Places where the humidity is excessively high. (Permissible humidity: 35~85%RH)
- Places filled with or likely to be filled with explosive or corrosive atmosphere.
- Danger due to dust, fire, earthquake and/or any externally imposed shock.
- Do not position the motor unit in a confined environment. The relative humidity should be 85% or below. Be careful not to allow dust and water inside the motor unit. The motor should not be splashed with water, otherwise it may short-circuit or burn.

[4] Keep the pump away from fire.

To prevent fire and explosions, do not place dangerous or inflammable substances near the pump.

[5] If pump is damaged

Do not operate a damaged pump, otherwise there may be electricity leakage or electric shocks.

[6] No remodeling

Never try to remodel the pump. This may cause a serious accident or damage.

[7] Limitation to disassembly or repair

Users are allowed to disassemble and repair the pump to the degree of the given description in "Disassembly and Assembly" in this manual.

[8] No dry running operation

Dry operation of the pump (pump operation without liquid inside) may cause damage to the pump internally. Never operate the pump dry. In the case of the MDH-(F), the sliding parts are self-lubricated and self-cooled. If the pump is operated dry or with the suction-side valve closed, damage may result.

* Countermeasures to be taken in case of dry operation

1. Turn off the power switch of the pump immediately and leave the pump as it is for more than 1 hour.

2. Prime the pump and fill the pump with liquid.

(Note that the pump should be supplied with liquid after leaving the pump empty for more than 1 hour.

Sudden supply of liquid may cause a crack in the part due to quenching effects.)

[9] Dry operation compatible type pump

The dry running operation compatible type pump (with D at the end of the model identification) can endure continuous dry running operation of not longer than 1 hour. Longer dry running operations, if repeated frequently, may result in wear of the sliding parts which rapidly affects the normal functioning of the inner part of the pump. The pump is designed so as not to develop cracks as a result of sudden cooling down with liquid immediately after dry operation. However, it is recommended that the pump be left as it is for about 20 minutes before running it with liquid.

* Pumps with E at the end of the model identification or without any symbol cannot endure dry running operation.

[10] Points to be noted when starting and stopping pump

Pay close attention to the following points to avoid water hammer action when starting and stopping pump operation. When the discharge-side piping is very long, extra attention is required.

(1) When starting the pump, first prime it. Then, close the discharge valve completely and turn on the power switch. After starting up the pump, open the discharge valve gradually and set it to the desired operation level.

(2) When stopping the pump, first close the discharge valve slowly. Turn off the power switch only after completely closing the discharge valve.

 **Caution**

In this procedure, never try to stop the pump quickly using a solenoid valve, etc. Quick closure may cause water hammer action, and the excessive pressure will destroy the pump.

[11] Allowable pressure limit

See the table 1~4 for allowable pressure limits of each model.

See that the discharge pressure does not exceed the allowable pressure limit.

Table 1

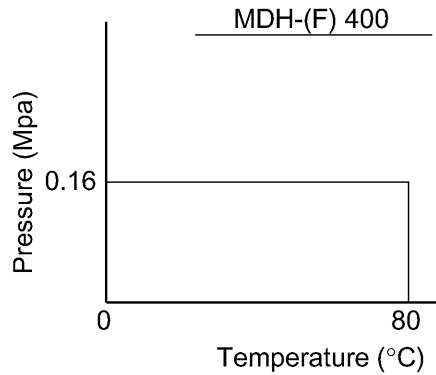

Table 2

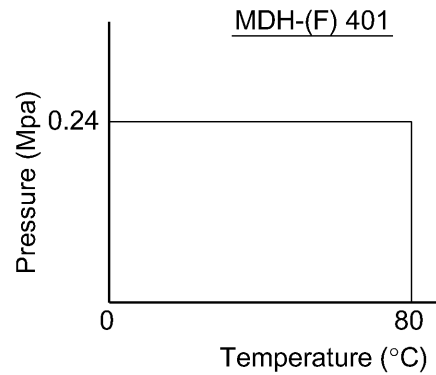

Table 3

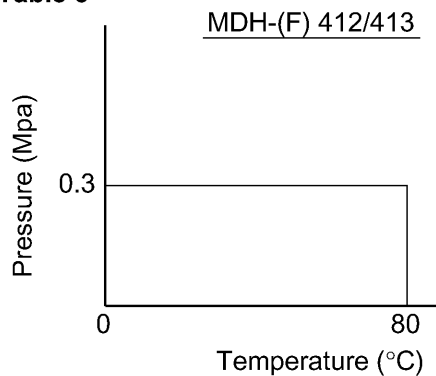
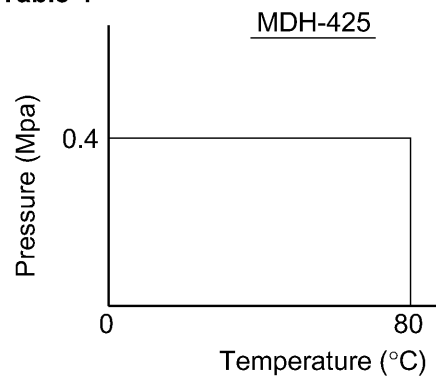

Table 4



[12] Use of slurry liquid

In principle, slurry liquid pumping is not possible. However, pumps with ceramic bearings (MDH-F AAV type only) can handle the pumping of slurry liquid with a density of 5wt% or less, grain size of 50 μm or less, and hardness of 80Hs or less. Prior to pumping such slurry liquid, be sure to confirm the operation feasibility with the supplier.

[13] Influence of specific gravity and viscosity of liquid on pump performance

If the specific gravity or viscosity of the liquid is higher than that of pure water, the shaft power, discharge volume, and pump head may vary somewhat. The delivered pump has been prepared to meet the specifications ordered by the user. To change the operating conditions after delivery, be sure to contact the supplier.

[14] Intermittent operation

Frequent start/stop switching considerably shortens the service life of the pump. Try to limit the switching frequency to six times or less per hour.

[15] Temperature humidity fluctuation

Temperature fluctuation may not change the performance of the pump itself. However, the liquid may change in terms of its viscosity, pressure, or corrosion resistance. Pay special attention to changes in liquid characteristics as a result of temperature fluctuation.

▶ Liquid temperature range: 0~80°C (pure water)
▶ Ambient temperature range: 0~40°C
▶ Humidity range: 35~85% RH

* Refer to the corrosion resistance table for the temperature ranges recommended for various types of liquid. For inquiries or consultation, contact the dealer you placed your order with.

[16] Disengagement of magnet coupling

Though the motor is running, the liquid is not circulated. (The pressure gauge on the discharge side points to "0" point approximately.)

When the magnet coupling disconnects, stop the pump within 1 minute. If operation is continued with the coupling in the disconnected mode, the power of the coupling will decrease considerably.

[17] Removal of grease (For MDH-F AAV type only)

Fluorocarbon grease is applied over the bearing in the MDH-F AAV type pumps. The grease may, depending on the type of liquid, melt into the liquid. Contact your dealer if you do not want the application liquid to be mixed with the grease.

2. Installation

[1] Installation position

- Install the pump as close to the suction tank as possible and in the lowest position available (for flooded suction).
- If the suction port of the pump is to be positioned higher than the suction tank (for suction lift), be sure to arrange for a foot valve in the priming pipe and suction pipe.
- * The lift head depends upon the liquid properties, temperature, and length of the suction piping. For details of the setup, consult Iwaki or your dealer.

[2] Indoor and outdoor use

The pump can be operated either indoors or outdoors. However, safety measures should be taken so as not to expose the motor and power distribution unit to flooding or other natural hazards.

[3] Installation site

Select an installation site that is flat and free of vibrations caused by nearby machines. Space sufficient for maintenance work should be provided.

■ Lifting

When lifting the pump, please pay attention to the following points.

- Do not hold, lift or carry the pump by gripping any parts made of plastic (such as the front casing and the flanges).
- The maximum weight of the pump is approximately 50 kg.
The pump should always be carried by two operators.
- Always place the pump horizontally with its base down.

■ Foundation preparation (before pump installation)

- [1] The area for anchoring the pump must be greater than the area of the base. If the anchoring area is not enough, the base may be destroyed due to a concentrated load on it.
- [2] If pump operation is to be subject to vibration (resonation with the piping, for example), provide an expansion joint between the pump and the piping. Otherwise, the piping, gauge, etc., may be damaged.
- [3] Installation advice
- Use anchor bolts to fasten the pump base firmly.
 - Install the pump horizontally.
 - Sufficient space is required to allow cool air from the motor fan to circulate.
 - Allow ample space around the pump for easy and efficient maintenance work.

3. Piping

Load of piping and momentum of piping for MDH-(F).

The permissible stress and moment applicable to pump connection arrangement are as shown below.

The piping should be designed and worked so that stress and moment, higher than those values indicated in the table, should not be applied to the pump.

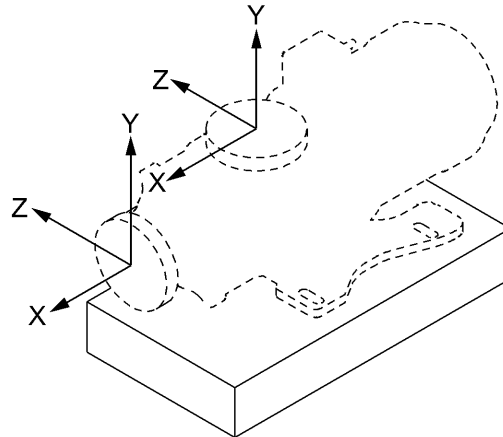

Table 9: Piping loadings

Forces of discharge piping

	Dia. of pipe (mm)
	40
	Load
Direction of load	kN
F _x	0.15
F _y : compression	0.20
F _y : tension	0.10
F _z	0.15

Forces of suction piping

	Dia. of pipe (mm)
	40, 50
	Load
Direction of load	kN
F _x	0.10
F _y	0.15
F _z	0.15

Moments of discharge piping

	Dia. of pipe (mm)
	40
	Load
Direction of load	kN·m
M _x	0.05
M _y	0.10
M _z	0.10

Moments of suction piping

	Dia. of pipe (mm)
	40, 50
	Load
Direction of load	kN·m
M _x	0.10
M _y	0.05
M _z	0.10

Example of piping

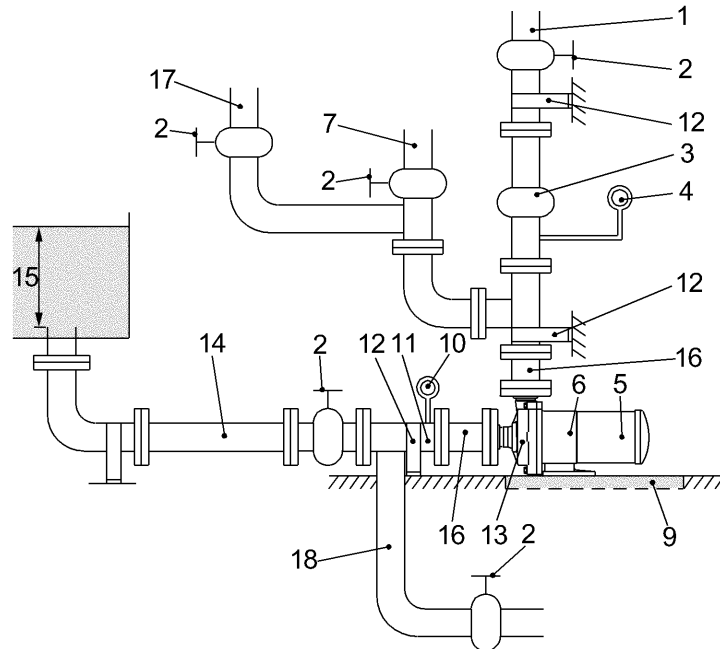

- | | |
|---|--|
| <ul style="list-style-type: none"> (1) Discharge pipe (Support the pipe to keep the pump free of piping load.) (2) Valve (3) Check valve (4) Pressure gauge (5) Motor (6) Pump (7) Air vent pipe (9) Drain ditch (10) Vacuum gauge | <ul style="list-style-type: none"> (11) Suction pipe (pipe diameter: D)
(The horizontal section should be as short as possible and there should be an ascending gradient of 1/100 toward the pump.) (12) Pipe support (13) Pump drain (14) Suction pipe (pipe diameter: D) (15) 2D, 500 mm or above (16) Expansion joint (17) Piping for flushing (Discharge side) (18) Piping for flushing (Suction side) |
|---|--|

■ Suction piping

- [1] The suction pipe should employ the flooded suction method if possible. The shortest pipe possible, with the minimum number of bends, should be used. Arrange a proper support under the suction pipe such as an expansion joint or the like so that the weight and thermal stress of the pipe are not applied to the pump.
- [2] Attach the coupling on the suction pipe carefully so as not to allow air inside the line. Air in the suction pipe may damage the system.
- [3] If suction is not good (e.g., the suction tank is a vacuum, the suction head is large, or the suction pipe is long), the condition $NPSHa > NPSHr + 0.5 \text{ m}$ should be established. For the $NPSHr$ level, refer to the standard performance curve.
- [4] When using an elbow pipe on the suction side, install a straight pipe with a length of at least 500 mm or 8 times the suction port diameter before the pump suction port. Provide the largest radius possible for the R of the bend.
- [5] Do not allow any projection where air may be trapped along the suction pipe. The suction pipe should have an ascending gradient of 1/100 toward the pump.

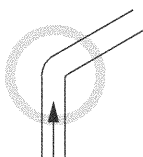
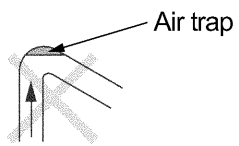
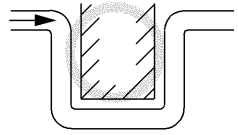
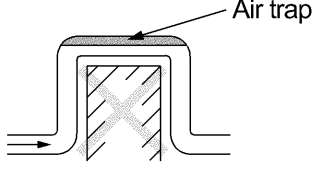
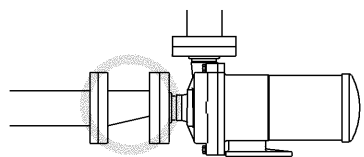
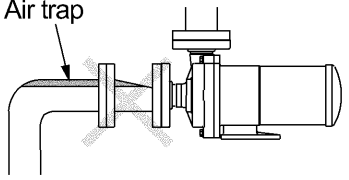
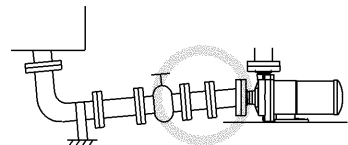
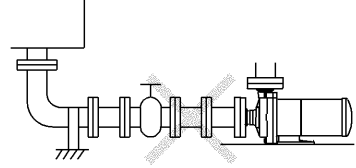
Good conditions		Unacceptable conditions	
○ good		✗ No good	
○ good		✗ No good	
○ good		✗ No good	
○ good		✗ No good	

-
-
- [6] If the diameters of the pump suction port and the suction pipe are different, use an eccentric reducer pipe. Connect the eccentric reducer pipe such that the upper surface is level. In any case, never use a suction pipe with a diameter smaller than that of the suction port.
- [7] It is also recommended, in the case of flooded suction, that a gate valve be installed on the suction pipe for easier overhaul inspection of the pump. Keep the gate valve fully open during ordinary pump operation; it is required to be closed only during an overhaul inspection.
- [8] When circulating a dangerous liquid, arrange the flushing pipes so that internal cleaning is possible when disassembling the pump.
- [9] The diameter of the suction pipe must be larger than that of the pump suction port.
- [10] The end of the suction pipe should be located 500 mm or more below the surface of the liquid.
- [11] A screen should be provided at the inlet in the suction tank to prevent the entry of foreign matter into the suction pipe. The end of the suction pipe should be 1~1.5 D (D: diameter of suction pipe) or more away from the bottom of the suction tank. Note that the entry of foreign matter may cause the pump to malfunction.
- [12] In the case of the suction lift method, install a foot valve on the suction pipe.

Note: The items [10], [11], and [12] above are applied to the suction lift method.

■ Discharge piping

- [1] Use a support so that the weight of the pipe is not applied to the pump as load.
- [2] If a method other than flooded suction is employed, install a priming pipe.
- [3] If the pipe is too long the piping resistance may increase, hampering the pump's performance. The diameter of the pipe should be determined by calculating the piping resistance.
- [4] A check valve should be installed if any one of the following conditions is present. When selecting the check valve, consider the check valve pressure limit (including the influence of water hammer or back flow onto the pump).
- ① The discharge piping is very long
 - ② The discharge lift exceeds 15 m
 - ③ The end of the discharge pipe is 9 m higher than the surface of the suction tank
 - ④ Several pumps are connected parallel to one another on the same piping

-
-
- [5] It is recommended that a valve be installed on the discharge pipe for the adjustment of discharge volume and for the prevention of overload onto the motor. When installing both a check valve and a valve, the check valve should be positioned between the pump and the valve.
 - [6] Do not fail to install a pressure gauge on the discharge piping.
 - [7] Install an air vent valve if the discharge pipe is very long horizontally.
 - [8] Install a drain valve for the drainage of liquid if there is a chance that the liquid in the discharge pipe might freeze.

4. Wiring

Electrical connections

ATTENTION

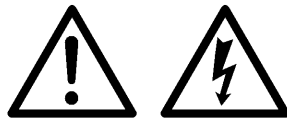

The electrical connection should be carried out by an authorized electrician in accordance with local regulations. Please make sure that the electrical data on the nameplate of the motor correspond to the electricity supply on which it will be used. Motors must be connected to a motor protection switch.

- [1] Use an electromagnetic switch that conforms with the specifications (voltage, capacity, etc.) of the pump motor.
- [2] If using the pump outdoors, waterproof the wiring to protect the switches from rainwater.
- [3] Electromagnetic switches and push buttons should be installed reasonably distant from the pump.

5. Operation Step

■ Operation instructions

- [1] Never operate the pump dry or with the suction-side valve closed. Otherwise, the inside of the pump will be damaged.
- [2] In the event of cavitation, stop the pump within a minute.
In addition, do not continue pump operation with the air mixed into the suction side.
- [3] If the magnet coupling disconnects, stop the pump within a minute. The power of the magnet coupling is reduced if operation is continued with the coupling disconnected.
- [4] The temperature fluctuation should not exceed 80 °C through the operation modes of starting, stopping, and operating the pump.
- [5] Before starting operation, close the discharge valve fully to prevent water hammer action upon start-up.
- [6] Note that pump operation with the discharge valve closed fully over a long time will raise the temperature of the liquid inside the pump and finally damage the pump.
- [7] In the event of a service power failure, turn off the power switch immediately and close the discharge valve.
- [8] Make sure that in allowable pressure levels are not applied to the pump. Refer to page 18 " [11] Allowable pressure limit" in "1. Handling Instruction."
- [9] Maximum pump surface temperature
The max. pump surface temperature of each model is shown in the table. Arrange protective measures in accordance with the temperature levels.

Model	Liquid temp (°C)	Maximum surface temperature when ambient temperature is at 40 °C. (°C)
MDH- (F) 400, 401, 422, 423 MDH-425	80	80

[10] Sound generated by pump

The level of sound generated by each type of pump is shown in the table. Arrange a muffling measures in accordance with the sound level. The procedure for sound measurement conforms to the EN 31201 (ISO11201).

(dB)

Model	MDH- (F) 400	MDH- (F) 401	MDH- (F) 422, 423	MDH-425
Sound Level	70	75	75	80

■ Preparation for start-up

Preparations should be made, as described below, in the case of initial operation after installation and in the case of restarting of operation after a long period of inactivity.

- [1] Thoroughly clean the inside of the pump and pipe. Then, supply liquid.
- [2] Tighten the flange connecting bolts and the installation bolts on the base.
- [3] After priming the pump, close the discharge valve fully.
Also, make sure the air-vent valve and flushing piping valve are closed.
- [4] In the case of the flooded suction method, measure the pressure in the flood pipe to confirm that the pump is filled with liquid.
- [5] In the case of the suction lift method, prime the pump.
- [6] Run the motor instantaneously to check for correct direction of motor rotation. The motor should run in the direction indicated with the arrow on the pump. If the direction is reversed, exchange any two wires of the three-phase power wires.

■ Operation

Operate the pump by following the steps given below.

No	Operation Step	Remarks
1	<ul style="list-style-type: none"> Close or open the valve. 	<ul style="list-style-type: none"> Suction valve—Fully opened Discharge valve—Fully opened
2	<ul style="list-style-type: none"> Prime the pump 	<ul style="list-style-type: none"> Confirm pump is filled with liquid. If pump is not filled with liquid, fill it in accordance with steps [5] and [6] of 'Start-up preparation'. After priming completely, close the discharge valve fully.
3	<ul style="list-style-type: none"> Check the motor for correct rotating direction. Switch on the power and then immediately switch off the power. 	<ul style="list-style-type: none"> Supply power immediately to run the pump only when checking the rotating direction of the pump. (Correct direction of pump operation is indicated with arrow on the pump. Check the direction of motor fan by looking at the fan through the fan cover.) Observe carefully to see if the motor fan slowly and smoothly stops rotating when the power switch is turned off. <p>Note: If the motor fan does not stop smoothly, the chances are that the pump is locked inside. In this case, contact your Iwaki dealer.</p>
4	<ul style="list-style-type: none"> Turn on the power and start the pump. Then, adjust the discharge pressure and discharge volume. <p>Following discharge volumes should be noted during pump operation.</p> <ul style="list-style-type: none"> ▶ MDH- (F) 400 and 401 : 10 l/min. or above ▶ MDH- (F) 422 and 423 : 20 l/min. or above ▶ MDH- 425 : 20 l/min. or above <ul style="list-style-type: none"> In case of automatic drive, too, close discharge valve before start-up and open valve slowly after start-up. <p>⚠ Caution Do not run pump longer than 1 minute against a fully closed discharge valve.</p>	<ul style="list-style-type: none"> Open valve carefully while paying attention to ampere meter, to prevent motor from being overloaded from excessive opening of valve. * Within 1 minute, open the discharge valve gradually and adjust the discharge pressure while checking the reading of the pressure gauge on the discharge side. (Otherwise, adjust the flow rate while checking the reading of the flowrate meter.) <p>⚠ Caution Total discharge pressure is increased to shut-off pressure after start of normal pump operation, open discharge valve gradually to set.</p>
5	<p>Points to be observed during operation.</p> <p>If pump enters continuous operation mode, check flow meter and confirm that pump operation is as per specifications.</p>	<ul style="list-style-type: none"> If flow meter is not available, check the values of discharge pressure, suction pressure, and electric current with reference to piping resistance.

■ Stoppage

	Check/Operation Step	Remarks
1	<ul style="list-style-type: none"> • Close discharge valve gradually. 	<ul style="list-style-type: none"> • Do not cause sudden closure with solenoid valve, etc., otherwise pump may be destroyed by water hammer action which is likely in case of long discharge piping.
2	<ul style="list-style-type: none"> • Turn off the power and stop pump operation. 	<ul style="list-style-type: none"> • Observe carefully whether the motor fan slowly and smoothly stops rotating. <p> Caution If not, check inside of pump.</p>
3	<p>Points to be observed when stopping pump</p> <ul style="list-style-type: none"> • If the pump operation is stopped during cold weather, liquid in pump may freeze and damage pump. When circulating a dangerous liquid, carry out internal cleaning by using flushing piping. Then drain the liquid fully. • Be sure to remove all liquid after stopping pump. In case of short-term suspension of operation, which does not allow for removal of liquid, use band heater, etc., to prevent liquid inside from freezing. • In event of power failure, turn off power switch and close discharge valve. 	

MAINTENANCE

1. <i>Causes of Trouble and Troubleshooting.....</i>	31
2. <i>Maintenance and Inspection</i>	34
3. <i>Spare Parts</i>	38
4. <i>Disassembly and Assembly</i>	39

1. Causes of Trouble and Troubleshooting

In the case of trouble, turn off the power supply immediately and refer to "1. Causes of Trouble and Troubleshooting".

Problem	Symptom on pump		Cause	Inspection and Measures
	With Discharge Valve Closed	With Discharge Valve Opened		
Liquid is not lifted.		Pressure gauge and vacuum gauge indicate 'zero'.	<ul style="list-style-type: none"> ● Not enough priming water ● Dry running. 	<ul style="list-style-type: none"> ○ Stop pump, feed sufficient priming water, and restart pump.
	Water goes down at once when priming is carried out.		<ul style="list-style-type: none"> ● Foreign matter is clogging foot valve. 	<ul style="list-style-type: none"> ○ Clean foot valve. ○ Check whether seat is clogged with foreign matter.
	Pressure is reduced if discharge valve is opened after start-up step.	Points of pressure gauge and vacuum gauge swing but return to zero at once.	<ul style="list-style-type: none"> ● Air enters through suction pipe or gasket section. 	<ul style="list-style-type: none"> ○ Check again whether connecting flange in suction piping is sealed airtight. ○ Check whether suction liquid level is abnormally lowered.
			<ul style="list-style-type: none"> ● Magnet coupling has disconnected. 	<ul style="list-style-type: none"> ○ Stop pump and use screwdriver to check for easy and smooth rotation of motor fan. ○ Measure electric current level to check for overload condition. ○ Check for foreign matter between impeller and casing. ○ Check whether the voltage level is normal.
	Pointer of pressure gauge never rises.	Pointer of vacuum gauge indicates a high value.	<ul style="list-style-type: none"> ● Speed of pump is too low. ● Pump rotates in reverse direction. 	<ul style="list-style-type: none"> ○ Check wiring and motor and make necessary repairs. ○ Exchange wires.
Discharge volume is small.		<ul style="list-style-type: none"> ● Strainer is clogged with foreign matter and liquid passage is blocked. 	<ul style="list-style-type: none"> ○ Eliminate the foreign matter in strainer. 	

Problem	Symptom		Cause	Inspection and Measures
	With Discharge Valve Closed	With Discharge Valve Opened		
Discharge volume is small.	Pointers of pressure gauge and vacuum gauge indicate normal values.	Pointer of vacuum gauge indicates extraordinarily high value.	● Air is trapped in suction pipe.	○ Inspect setup condition of suction pipe and modify it if necessary.
			● Inlet section of impeller unit is clogged with foreign matter.	○ Disassemble unit partially and eliminate foreign matter.
		Pointers of pressure gauge and vacuum gauge swing.	● Air enters through suction pipe or gasket section.	○ Check connecting section of suction pipe and tighten it if necessary.
			● Discharge side of pump is clogged with foreign matter.	○ Eliminate foreign matter in the pump. ○ Eliminate foreign matter or scale inside pipe.
		Pointer of vacuum gauge indicates a high value while that of pressure gauge indicates normal value.	● There is an air trap or resistance in suction pipe.	○ Check whether there is protruding section in suction pipe and take necessary measures.
		Pointer of pressure gauge indicates high value while that of vacuum gauge indicates normal value.	● There is portion in discharge pipe that causes resistance, or actual head and loss of head are too high.	○ Check actual head and piping loss of discharge pipe and take necessary measures.
	Pointer of pressure gauge indicates low value and that of vacuum gauge indicates extraordinarily low value.	Pointers of pressure gauge and vacuum gauge indicate low values.	● Rotation direction is reversed.	○ Exchange wires.

Problem	Symptom		Cause	Inspection and Measures
	With Discharge Valve Closed	With Discharge Valve Opened		
Motor is overheated.			<ul style="list-style-type: none"> ● Voltage is lowered. ● Overload. ● Ambient temperature is high. 	<ul style="list-style-type: none"> ○ Check whether the voltage and frequency levels are adequate. ○ Check whether the specific gravity and viscosity of liquid are adequate. ○ Stop pump and use a screwdriver, etc., to check whether the motor fan rotates easily and smoothly. ○ Improve air ventilation.
Discharge volume is suddenly lowered.		Pointer of vacuum gauge indicates high value.	<ul style="list-style-type: none"> ● Strainer is clogged with foreign matter. 	<ul style="list-style-type: none"> ○ Eliminate foreign matter.
Pump vibrates.			<ul style="list-style-type: none"> ● Foundation is defective. ● Anchor bolt is loose. ● Suction pipe is closed. Cavitation is caused. ● Wear or melting of pump bearing. ● Magnet capsule or spindle is damaged. ● Dynamic balance of drive magnet assembly fluctuates. ● Impeller and/or magnet capsule is in contact with fixing section. ● Wear of motor bearing. 	<ul style="list-style-type: none"> ○ Reinstall. ○ Retighten bolts. ○ Clean, and eliminate cause of cavitation. ○ Replace. ○ Replace. ○ Eliminate cause or replace. ○ Replace. ○ Replace bearing or motor.

2. Maintenance and Inspection

■ Daily inspection

- [1] Check whether the pump operates smoothly, without generating any abnormal noise or vibration.
- [2] Check the level of the liquid in the suction tank and the suction pressure.
- [3] Compare the discharge pressure and electric current measured during operation with the values indicated on the motor nameplate for the verification of normal pump load.
 - * Note that the values indicated on the pressure gauge vary in proportion to the specific gravity of the liquid. The cock of the pressure gauge or vacuum gauge must be opened only when measurement is carried out. It must be closed upon the completion of each measurement. If the cock remains open during pump operation, the meter mechanism may be affected by abnormal pressure caused by water hammer action.
- [4] If a spare pump is available, activate it from time to time to keep it ready for use any time.
- [5] Check to be sure there is no liquid leakage in the pump before operating it. If leakage is detected, never try to operate the pump.
- [6] Check to be sure the discharge pressure, discharge flow rate, and motor power supply voltage do not fluctuate during pump operation. If considerable fluctuation of the respective values occurs, refer to "1. Causes of Trouble and Troubleshooting" for correct measures.

■ Periodic inspection

To ensure efficient and smooth operation of the pump, carry out periodic inspections by following the procedures described below. The overhauling and repair work for Iwaki pumps must be performed by qualified personnel who have been trained. User's failure to observe this instruction exempts Iwaki from responsibility for personal injury or damage to the equipment or facility which may result from its misuse.

Inspection Timing	Part Name	Check Points
Every 6 months * Inspection record should be kept.	Drive magnet unit	<ul style="list-style-type: none"> ● Are there slide-scratches? ● Is housing fixed normally? Is hex. socket set screw loose? ● Are inner perimeter of magnet and motor shaft coaxial? (Max. eccentricity: 1/10 mm)
	Rear casing	<ul style="list-style-type: none"> ● Are there slide-scratches in bore? ● Are there cracks on liquid end part? ● Wear of spindle tip. ● Stains in rear casing.
	Magnet capsule	<ul style="list-style-type: none"> ● Are there slide-scratches in the rear section or in the cylindrical body? ● Are there cracks in resin of rear section or in cylindrical body? ● Wear of bearing. (Measure dimensions.) ● Condition of fixed with impeller.
	Impeller	<ul style="list-style-type: none"> ● Wear of mouth ring. (Measure dimensions.) ● Wear of impeller thrust. ● Are there cracks? ● Are there cavitation marks (such as mouth ring condition, wear, seizure)? ● Stains or clogging inside impeller. ● Dimensional change in impeller.
	Front casing	<ul style="list-style-type: none"> ● Stains in liquid contacting part. ● Are there cracks? ● Are there wear, slide-scratches, or cracks in thrust ring? ● Is drain clogged? ● Are there expansion or cracks on O ring. ● Slide-scratches in unlikely position.
	Spindle	<ul style="list-style-type: none"> ● Are there cracks? ● Wear of abrasive section.

■ Wear limits of bearing and spindle

Unit: mm

Model \ Part	MDH-(F) 400		MDH-(F) 401, 422, 423 MDH-425	
	Upon Shipment	Upon Replacement	Upon Shipment	Upon Replacement
Inner diameter of bearing	18	19	26	27
Outer diameter of spindle	18	17	26	25

- * If the difference between the inner diameter of the bearing and the outer diameter of the spindle exceeds 1 mm, either the bearing or the spindle whichever has the greater wear, should be replaced regardless of the values in the above table. In the case of a ceramics bearing type pump, the spindle and the bearing should be replaced simultaneously.
- * Initial wear may appear in the sliding parts in the first stages of operation. This should not be mistaken for an abnormal condition.

■ Wear limit of mouth ring

Unit: mm

Model	MDH-(F) 400, 401, 422, 423 MDH-425
Thickness upon shipment	8
Thickness upon replacement	6

- * The step between the surfaces of the mouth ring and the impeller upon shipment is 2 mm. The wear limit of the mouth ring is reached when this step is reduced to 0 mm. Replace the mouth ring then.

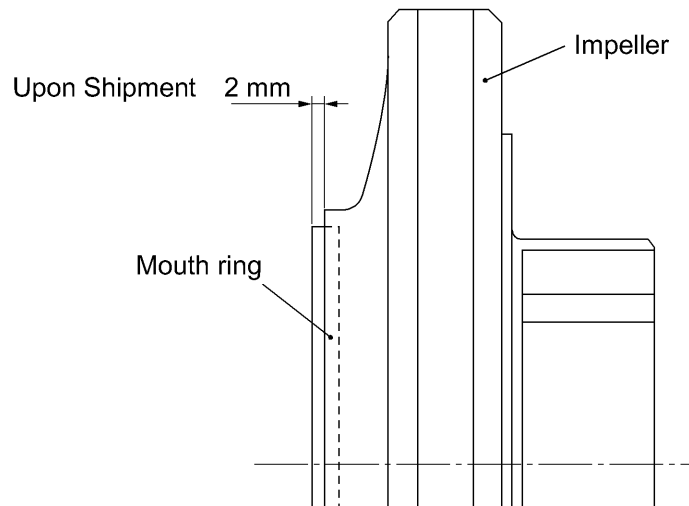

■ Wear limits of tips of impeller thrust and spindle

Pumps whose model identification codes have D or E at the end are designed to result in contact between the impeller thrust tip and the spindle tip in the event of an abnormal operating condition (cavitation, dry operation, etc.). If the tips are worn out beyond the wear limit level, the pump is subject to serious damage. The condition of the tips in contact must be checked if an abnormal profile such as dry operation or cavitation lasts a total of over 3 hours.

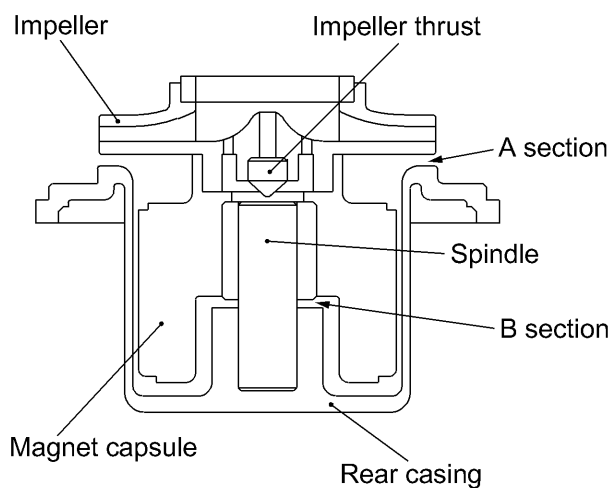
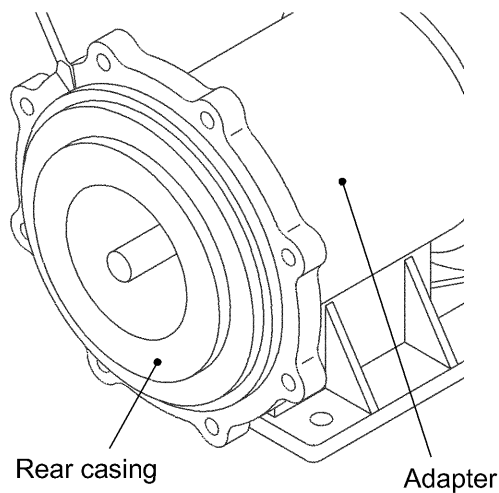

■ Wear checking steps

[1] Remove the rear casing from the adapter and insert the magnet capsule attached to impeller can into the rear casing.

[2] Rotate the impeller slowly by hand, with it positioned on the rear casing.

- Tips are not worn out beyond wear limit

The impeller and magnet capsule will continue to rotate smoothly.

- Tips are worn out beyond wear limit

The impeller and magnet capsule will not continue to rotate smoothly. The contact at the A section or B section, as shown in the figure of the left, does not allow for the continuous smooth rotation of the impeller and the magnet capsule because the tips of the two elements are excessively worn. In this case, replace the impeller and rear casing with new ones.

3. Spare Parts

Appropriate spare parts are necessary to ensure long, continuous operation of the pump. It is recommended that consumable parts be kept at hand constantly. When placing an order, supply the following information.

- ① Name of part and part number (in accordance with the drawings in this instruction manual)
- ② Pump model number and manufacturing number (as indicated on the pump nameplate)
- ③ Drawing number if you have received the Iwaki-approved drawing

No.	Part name	Material	MDH-400	MDH-401	MDH-422	MDH-423	MDH-425
2	Rear casing	CV, RV	MDH 0832	MDH 0851	MDH 0957		
		FE	MDH 1100	MDH 1105	MDH 0957		
8 + 21	Magnet capsule	CV, FE	MDH 0023	MDH 0093	MDH 0963	MDH 0977	MDH 1047
		RV	MDH 0022	MDH 0092	MDH 0964	MDH 0978	MDH 1048
②③	O ring	CV, RV	MDH 0008	MDH 0080	MDH 0116		
		FE	MDH 0009	MDH 0081	MDH 0117		
3 + 19 + 22	Impeller 50Hz	CV, RV	MDH 0828	MDH 0847	MDH 0991	MDH 1001	MDH 1043
		FE	MDH 0829	MDH 0848	MDH 0992	MDH 1002	MDH 1044
	Impeller 60Hz	CV, RV	MDH 0830	MDH 0849	MDH 0993	MDH 1003	MDH 1045
		FE	MDH 0831	MDH 0850	MDH 0994	MDH 1004	MDH 1046

No.	Part name	Material	MDH-F400	MDH-F 401	MDH-F 422	MDH-F 423
2	Rear casing	AAV	MHF 0855	MHF 0870	MHF 0981	
		CFV	MHF 0856	MHF 0871	MHF 0981	
8 + 21	Magnet capsule	AAV	MHF 0938	MHF 0061	MHF 0989	
		CFV	MHF 0937	MHF 0062	MHF 0990	
②③	O ring	AAV	MHF 0007	MHF 0044	MHF 0081	
		CFV	MHF 0007	MHF 0044	MHF 0081	
3 + 19 + 22	Impeller 50Hz	T	MHF 0849	MHF 0864	MHF 1016	MHF 1023
		V	MHF 0850	MHF 0865	MHF 1017	MHF 1024
		W	MHF 0851	MHF 0866	MHF 1018	MHF 1025
	Impeller 60Hz	X	MHF 0852	MHF 0867	MHF 1019	MHF 1025
		Y	MHF 0853	MHF 0868	MHF 1020	MHF 1026
		Z	MHF 0854	MHF 0869	MHF 1021	MHF 1027

- ▶ Circle around a number indicated the part is consumable.
- ▶ Specially designed flanges 40 mm or 50 mm bore are optionally available for ISO NP10 , ANSI 150 lbs or JIS 10K standard piping. No seal tape is required for piping because of the secure Oring sealing.

4. Disassembly and Assembly

Caution

- When disassembling the pump, put a mark on each lead in order to prevent the pump from reversing rotation after rewiring, if you disconnect leads from the motor.
- Since the magnet used in the pump is very powerful, be careful not to get your fingers caught between the elements during the disassembly and assembly processes. Also, pay attention to prevent metal pieces or metal powder from adhering onto the pump.
- Do not bring any electronic device that may be influenced by strong magnetic power into the pump magnetic field.
- Prior to disassembly or assembly, close the suction valve and discharge valve fully.
- The piping and the pump often retain liquid. When a dangerous liquid is handled, wear protectors (goggles, rubber gloves, etc.) when disconnecting the pipes.

■ Disassembly

[1] Remove the front casing from the adapter.

Remove the hex socket bolts (or hex bolts) and take out the front casing from the adapter.

Then, clean the inside of the pump.

Caution

Strong impacts may crack the casing. Do not hit it with a tool.

Note

- * The spindle is integrated with the rear casing, not pressed into the front casing.
- * During disassembly, discharge the liquid from the casing and clean the inside of the pump.

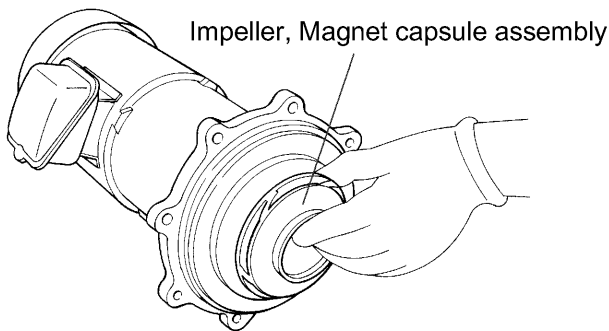

- [2] Pull out the impeller and magnet capsule assembly toward yourself.

Be careful not to scratch the surface of each part. Since the magnet capsule is strongly magnetized, store it in a place free of metal pieces or metal powder. Handle the front casing, magnet capsule, and impeller with extra care so as not to scratch the sliding surface and sealing surface.

* Note on MDH-(F) 400, 401.

Then disconnecting the impeller from the magnet capsule, hold the magnet capsule by hand and strike the rear of the impeller gently with a resin hammer. When the impeller is tightly pressed in and disconnection is difficult, warm the impeller and magnet capsule in hot water (about 90 °C) for 5 minutes prior to striking the impeller with the hammer.

* Note on MDH-(F) 422, 423 and MDH-425

The impeller is fixed to the magnet capsule by screwing. When removing the impeller from the magnet capsule, hold the magnet capsule by hand and rotate the impeller counterclockwise (from the impeller side).

If thread part is too tight and the impeller is not disconnected from the magnet capsule, put the magnet capsule with the impeller on hot water (about 90°C) for 5 minutes. And then rotate the impeller counterclockwise. Beware of scald while this procedure.

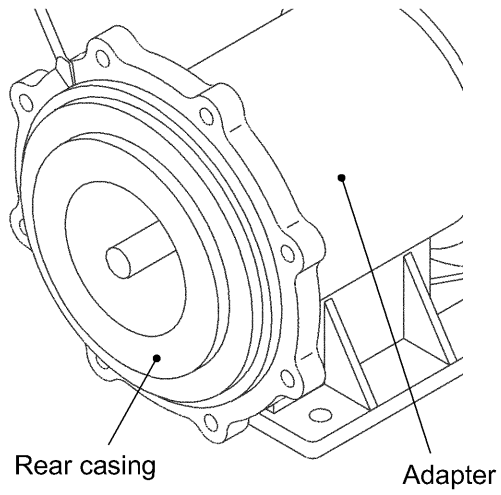

[3] Remove the rear casing.

Insert a flat-head screwdriver into the perimeter of the rear casing and pull the rear casing forward while lifting it slightly up.

- * Pay extra attention not to scratch the sealing surface.
- * The rear casing and the spindle are integrated. It is not possible to replace only the spindle.

■ Assembly

The pump should be assembled by carrying out the steps of disassembly in reverse. Pay attention to the following points.

● Replacement of O ring

When replacing the O ring, be sure to install a new one. In addition, see that the O ring is not twisted or pressed by another part.

* The sealing section should be cleaned free of dust or scratches before installation.

● Fastening Bolts

Fasten the bolts in diagonal order by applying the fastening torque shown in the following table. Apply an equal torque to each bolt.

Model	Type	Fastening torque N·M	Size of bolts
MDH-(F) 400	Hex. head bolt	11.8	M8 × 35L, M8 × 55L
MDH-(F) 401			M8 × 40L, M8 × 65L
MDH-(F) 422, 423	Hex. socket head bolt	14.7	M10 × 45L, M10 × 85L
MDH-425			

* Note on MDH-(F) 400 and 401

[1] Install the rear casing onto the adapter.

[2] Attach the impeller onto the magnet capsule. If this is difficult, warm the magnet capsule in hot water (about 90 °C) for 5 minutes before attaching it.

[3] Check that there is no metal piece or other matter adhering onto the magnet capsule. Then, insert the magnet capsule and impeller slowly into the rear casing.

* Note that the magnetic force of the magnet capsule is very strong.



Caution

The spindle is mounted on the rear casing side. Assembly should be done carefully so as not to damage the spindle and the bearing.

[4] Confirm there is no dust or scratches on the seal surface of the front casing. Then, attach the O ring onto the front casing.

[5] Fasten the hex head bolts in diagonal order, applying an equal torque to each.

* Note on MDH-(F) 422, 423 and MDH-425

[1] Attach the impeller to the magnet capsule.

Rotate the impeller clockwise, and tightly screw it in the magnet capsule. If it is hard to screw in, warm the magnet capsule putting it in hot water of approx. 90 deg.C. for 5 minutes.

[2] Insert the impeller and the magnet capsule unit to the rear casing. Then, the rear casing, the impeller and the magnet capsule set is installed onto the foot support.

⚠ Caution

- **Since the magnet used in the pump is very powerful, be careful not to get your fingers caught between elements by inserting wood pieces or plastic pieces between the rear casing and the foot support.**

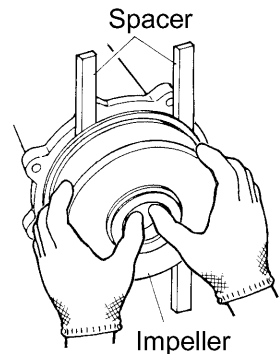

[3] Confirm there is no dust or scratches on the seal surface of the front casing. Then, attach the O ring onto the front casing.

[4] Attach the front casing onto the foot support.

[5] Fasten the hex. socket head bolts in diagonal order, applying an equal torque to each.



IWAKI CO.,LTD. 6-6 Kanda-Sudacho 2-chome Chiyoda-ku Tokyo 101-8558 Japan
TEL:(81)3 3254 2935 FAX:3 3252 8892(<http://www.iwakipumps.jp>)

()Country codes

Singapore : IWAKI Singapore Pte. Ltd.	TEL : (65)763 2744	FAX : 763 2372	Germany : IWAKI EUROPE GmbH	TEL : (49)2154 9254 0	FAX : 2154 1028
Indonesia : IWAKI Singapore (Indonesia Branch)	TEL : (62)21 690 6607	FAX : 21 690 6612	Italy : IWAKI Italia S.R.L.	TEL : (39)02 990 3931	FAX : 02 990 42888
Malaysia : IWAKIm Sdn. Bhd.	TEL : (60)3 7803 8807	FAX : 3 7803 4800	Denmark : IWAKI Pumper A/S	TEL : (45)48 24 2345	FAX : 48 24 2346
Taiwan : IWAKI Pumps Taiwan Co., Ltd.	TEL : (886)2 8227 6900	FAX : 2 8227 6818	Sweden : IWAKI Sverige AB	TEL : (46)8 511 72900	FAX : 8 511 72922
Thailand : IWAKI (Thailand) Co.,Ltd.	TEL : (66)2 320 1303	FAX : 2 322 2477	Finland : IWAKI Suomi Oy	TEL : (358)9 2742714	FAX : 9 2742715
Hong Kong : IWAKI Pumps Co., Ltd.	TEL : (852)2 607 1168	FAX : 2 607 1000	Norway : IWAKI Norge AS	TEL : (47)66 81 16 60	FAX : 66 81 16 61
China : GFTZ IWAKI Engineering & Trading Co., Ltd.	TEL : (86)20 8435 0603	FAX : 20 8435 9181	France : IWAKI France S.A.	TEL : (33)1 69 63 33 70	FAX : 1 64 49 92 73
China : IWAKI Pumps Co., Ltd. (Beijing office)	TEL : (86)10 6442 7713	FAX : 10 6442 7712	U.K. : IWAKI PUMPS (UK) LTD.	TEL : (44)1743 231363	FAX : 1743 366507
China : IWAKI Pumps (Shanghai) Co., Ltd.	TEL : (86)21 6272 7502	FAX : 21 6272 6929	Switzerland : IWAKI (Schweiz) AG	TEL : (41)32 3235024	FAX : 32 3226084
Philippines : IWAKI Chemical Pumps Philippines, Inc.	TEL : (63)2 888 0245	FAX : 2 843 3096	Austria : IWAKI (Austria) GmbH	TEL : (43)2236 33469	FAX : 2236 33469
Korea : IWAKI Korea Co.,Ltd.	TEL : (82)2 3474 0523	FAX : 2 3474 0221	Holland : IWAKI Holland B.V.	TEL : (31)297 241121	FAX : 297 273902
U.S.A. : IWAKI WALCHEM Corporation	TEL : (1)508 429 1440	FAX : 508 429 1386	Spain : IWAKI Iberica Pumps, S.A.	TEL : (34)943 630030	FAX : 943 628799
Australia : IWAKI Pumps Australia Pty. Ltd.	TEL : (61)2 9899 2411	FAX : 2 9899 2421	Belgium : IWAKI Belgium n.v.	TEL : (32)1430 7007	FAX : 1430 7008