

IWAKI
Air-Driven Bellows Pump

FA-2/40 Type

Instruction Manual

⚠ Read this manual before use of product

Thank you for having selected the Iwaki Bellows Pump FA Series. This instruction manual, which is divided into 5 sections, namely “Safety Section,” “Outline Section,” “Installation Section,” “Operation Section” and “Maintenance Section,” deals with the correct handling and operation procedures for the pump. To make maximum use of the pump and to ensure safe and long operation of the pump, please read this manual thoroughly and carefully prior to operating the pump.

Contents

IMPORTANT INSTRUCTIONS	1
Safety Section (Instructions to prevent accidents)	2
 OUTLINE OF PRODUCT	 5
1. Unpacking and Inspection	6
2. Operation Principle	6
3. Identification Codes	7
4. Specifications	7
5. Outer Dimensions/Mass.....	8
6. Names of Parts and Structure of Pump	9
 INSTALLATION SECTION	 11
1. Before Use (Handling instructions)	12
2. Installation, Piping, and Wiring	14
 OPERATION SECTION	 28
1. Preparation	29
2. Pump Operation	29
3. Points to Be Observed in Operation.....	30
 MAINTENANCE SECTION	 31
1. Causes of Trouble and Troubleshooting	32
2. Maintenance and Inspection	34
 REPAIR SERVICE	 35



This instruction manual should be kept on hand by the end user for quick reference. It is recommended that each user, after reading the instruction manual thoroughly, place it in a position close to the pump system and where it may be easily accessed by any user at any time whenever necessary.

Concerning any points you wish to know more about, contact Iwaki, an Iwaki branch office, or an Iwaki distributor.



Important Instruction

For the Safe and Correct Handling of the Pump

- Read the "Safety Instructions" sections carefully to prevent accidents involving your customers or other personnel and to avoid damage or loss of other assets. Always follow the instructions and advice found in these sections.
- Observe and abide by the instructions described in this manual. These instructions are very important for protecting pump users from dangerous conditions and situations related with the use of the pump system.
- The symbols relate to the following meanings described below:

 Warning	Nonobservance or misapplication of the contents of the "Warning" section could lead to a serious accident, including death or injury.
 Caution	Nonobservance or misapplication of the contents of the "Caution" section could lead to serious physical injury to the user or serious damage to the product.

Types of Symbols

-  Indicates that "Warning" or "Caution" must be exercised. Inside this triangle, a concrete and practical image provided as a warning or caution message is depicted.
-  Indicates a prohibited action or procedure. Inside or near this circle, a concrete and practical image of the activity to be avoided is depicted.
-  Indicates an important action or procedure which must be performed or carried out without fail. Failure to follow the instructions herein can lead to malfunction or damage to the pump.

Safety Section

WARNING

- **Look around**

Make sure there is no one around the pump when connecting the power cable. The power supply switch is not provided on the pump. Upon supplying power to the controller, air is supplied and the pump starts immediately.



- **Do not remodel pump**

Never try to remodel the pump. Remodeling may be a cause of serious accident or damage. Iwaki takes no responsibility for the accident or damages that may result due to any remodeling without first obtaining permission from Iwaki.



- **For specified application only**

The use of a pump in any application other than those clearly specified may result in injury or damage to the pump. Use the pump strictly in accordance with the pump specifications and application range.



- **Do not drain**

Never discharge hazardous liquid, including but not limited to chemical liquid, over the ground or floor in the plant directly. Abide by local regulations when disposing of hazardous substances.



- **Do not touch**

Touching the pump or piping which is extremely hot due to the circulation of a hot liquid may cause severe burns. Arrange adequate hand-protective measures when feeding a liquid at temperatures higher than 50 °C.



CAUTION

- **Do not exceed the specified voltage**

Do not supply power voltage in excess of the level specified. Otherwise, a fire or electric shock may result.



- **Wear protectors**

Never fail to wear protective gear (protective goggles, cap, mask, acid-resistant gloves) when disassembling, assembling, or maintaining the pump. In addition, clean the pump carefully with pure water before working on the pump.



- **Qualified operator only**

The pump must be operated only by operator (s) who have been trained in the safe operation of the pump.



- **Countermeasure for static electricity**

When low electric conductivity liquid such as ultra-pure water and fluor inactive liquid (e.g. Fluorinert™) are handled, the static electricity may be generated in pump, which may cause static discharge and break down. Take countermeasure to avoid and remove static electricity.



Safety Section

CAUTION

- **Lifting pump**

If a lifting rope or chain breaks or is cut when lifting the pump, a fatal or serious injury to person may be resulted from the accident. Select a lifting rope or chain which is strong enough for the load of the pump. Furthermore, no person should be allowed to get under the pump while it is being lifted.



- **Power OFF**

Make sure no one turns on the power switch while work is being done on the pump. Be sure to turn off the power switch before you start any maintenance/repair work concerning the pump. If the working site is noisy or under conditions of low visibility, you should display a notice which clearly states "WORKING," near the power switch in order to inform other personnel about the situation. Power ON executed by any other person than the operator/service personnel may result in a serious accident. The operator must take special precautions to avoid accidents.



Power off

- **Storage limit**

Do not store the pump in places where an explosive atmosphere is located, dust is generated, or corrosive gas (such as chlorine gas) is present. Otherwise, a fire may be caused or the health of personnel may be jeopardized.



Prohibited

- **Ventilate site**

When handling a toxic liquid or odorant, ventilate the working site well. In addition, wear protective gear (protective mask, goggles, gloves, etc.).



- **Disposal of used pump**

Disposal of used or damaged pumps must be done in accordance with local laws and regulations. (Consult a licensed industrial waste products disposing company.)



Caution

- **Send-back to Iwaki**

When sending the pump back to Iwaki, drain the liquid out of the pump and clean thoroughly with water to prevent any accidents during transportation.



Caution

- **Pump stroke speed**

Do not run the pump at a stroke speed higher than 150spm (75 cycles) [FA-40VEW: 80spm (40 cycles)]. A stroke speed higher than 150spm [FA-40VEW: 80spm] shortens the life of the bellows.



Caution

Pump type	Max stroke speed
FA-2	150spm (75 cycles)
FA-40VEW	80spm (40 cycles)

- **Supply air pressure**

Supply air pressure should not exceed 0.392MPa. Otherwise, the bellows may be deformed.



Caution

Safety Section

CAUTION

- **Liquid temperature range**

Follow the specified operation liquid temperature range.

FA-2/40: 5~100°C



Caution

- **Prohibited liquids**

Do not operate the pump with the following liquids.

- Liquid easily crystallized
- Liquid containing slurry
- Solvent naphtha



Prohibited

- **Liquids to be handled with care**

Remover or solvent-type liquid should be handled carefully.



Caution

- **Air exhaust port**

Do not narrow the air exhaust port (for example by reducing the tube diameter). Otherwise the bellows may be deformed due to the residual pressure.



Caution

- **During pump operation**

- Make sure to open both the suction and discharge-side valves fully. In addition, confirm that the piping is fully supplied with liquid.



Caution

- **Stopping pump operation**

- When stopping pump operation, release the pressure on the discharge side first. Otherwise, the bellows may be deformed due to the residual pressure on the pump discharge side.
- If a valve is provided on the discharge side, do not close the valve upon stopping the pump. The resulting impactive pressure may deform the bellows or connecting plate.



Caution

- **Pump at halt**

- Do not supply air to both the right and left air-supply ports at the same time, to prevent the bellows from becoming deformed.
- Suspending pump operation for a prolonged period without removing the liquid inside the pump chamber may cause corrosion of metallic parts due to permeation of the liquid's gas content. To prevent this problem, run the pump for about 10 minutes a day to replace the air in the chamber when the pump operation is suspended for longer than 2 to 3 days.



Caution

- **Note for electrode**

- There is a case that electrode can not detect leakages. This comes from operating condition (supply air pressure etc.) and size of cracks on the bellows. Please contact IWAKI for detail.



Caution

OUTLINE OF PRODUCT

This section deals with operating principle, type and specifications of the pump as an introduction of the bellows pump.

<i>1. Unpacking and Inspection.....</i>	<i>6</i>
<i>2. Operating Principle</i>	<i>6</i>
<i>3. Identification Codes</i>	<i>7</i>
<i>4. Specifications.....</i>	<i>7</i>
<i>5. Outer Dimensions/Mass.....</i>	<i>8</i>
<i>6. Names of Parts and Structure of Pump</i>	<i>9</i>

1. Unpacking and Inspection



After unpacking the product, check the following points to ascertain that the product is exactly as you ordered. If you find anything wrong, please contact your dealer.

- [1] Does the model indicated on the nameplate represent what you ordered?
- [2] Has the pump or any part of it been damaged as the result of an accident or mishandling in transit?
- [3] Have all the special accessories, if ordered, been delivered with the pump?
 - ① Controller
(AC-1 type, FD-1 type, SC-1 type)
 - ② Quick exhaust valve
- [4] The third numeral of MFG.No. shows the year the product was manufactured.

(e.g.) XX6XXXXX

"6" shows the product manufactured in the year 1996

2. Operation Principle

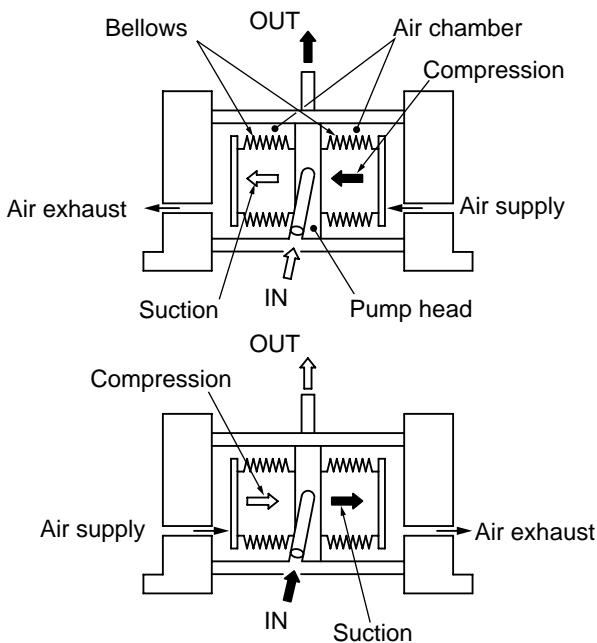

⇒⇒: Liquid flow
→: Air supply flow

Suction/compression: Created by bellows stroke

Iwaki's air-driven bellows pumps are made entirely of fluororesin and designed for semiconductor manufacturing processes.

The pump unit consists of two air chambers and a pair of bellows. These bellows move reciprocally in the air chambers for suction and discharge, by which the liquid is pumped continuously.

- [1] Liquid is sucked into the pump head through the suction port by the expansion (suction motion) of the bellows.
- [2] The liquid is then forced out of the pump head through the discharge port by the compression (discharge motion) of the bellows.

3. Identification Codes

FA - 2 E - 01
 ① ② ③ ④

- ① Series code
 FA: Pump for medium-temperature liquid
- ② Maximum discharge volume
 2 : 2 ℓ / min
 40 : 40 ℓ / min
- ③ Pump driving method
 FA-2
 No symbol : Air pulse timer type
 E : Proximity detector type
 FA-40
 VEW : Proximity detector type
- ④ Special specifications
 No symbol: Standard specifications
 S: Special specifications (01, 02)

4. Specifications

	Item	FA-2	FA-40
General Specifications	Max. discharge volume (Note 1)	2 ℓ / min	40 ℓ / min
	Max. stroke speed	150spm	80spm
	Self-priming ability (Note 2)	1m	2m
	Liquid temp. range	5-100°C	
	Max. supply air pressure	0.392MPa	
	Liquid-contacting material	PFA, PTFE	
	Pump connection port diameter	Rc 1/8"	Rc 1"
	Supply air connection port diameter	Rc 1/4"	Rc 3/8"
	Max. air consumption (at max. discharge volume)	50N ℓ / min	200N ℓ / min
	Ambient temp.	0-40°C	
Driving method	External forced switching of driving air		
Proximity detector arrangement	Type	High-frequency type proximity detector	
	Output type	NPN DC open/close output	
	Source voltage	DC10V-DC30V	
	Lead wire	2m	

Note 1. The maximum discharge volume value is based on pure water at room temperature.

Note 2. The self-priming value is based on the maximum stroke speed with pure water at room temperature.

5. Outer Dimensions/Mass

● FA-2E type

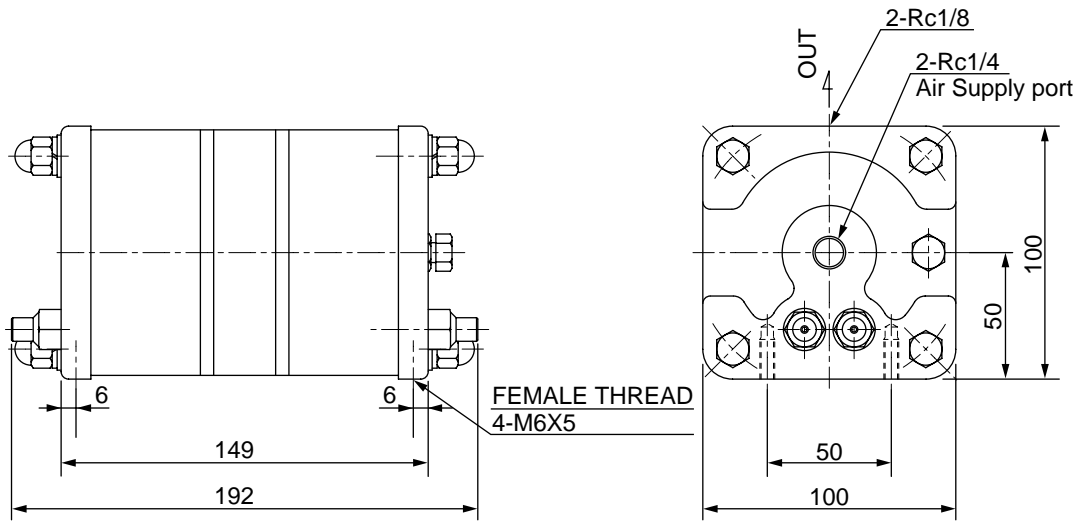

Mass : 3.7kg

● FA-40VEW type

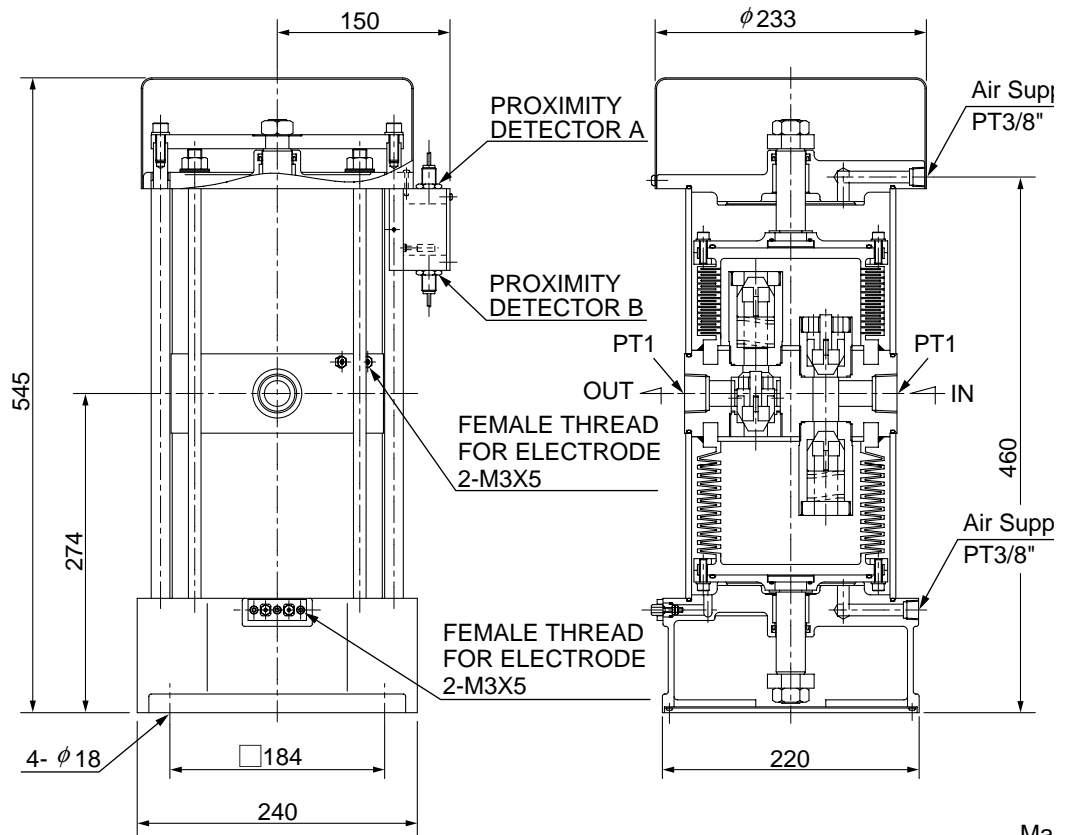

Ma

6. Names of Parts and Structure of Pump

- FA-2E type

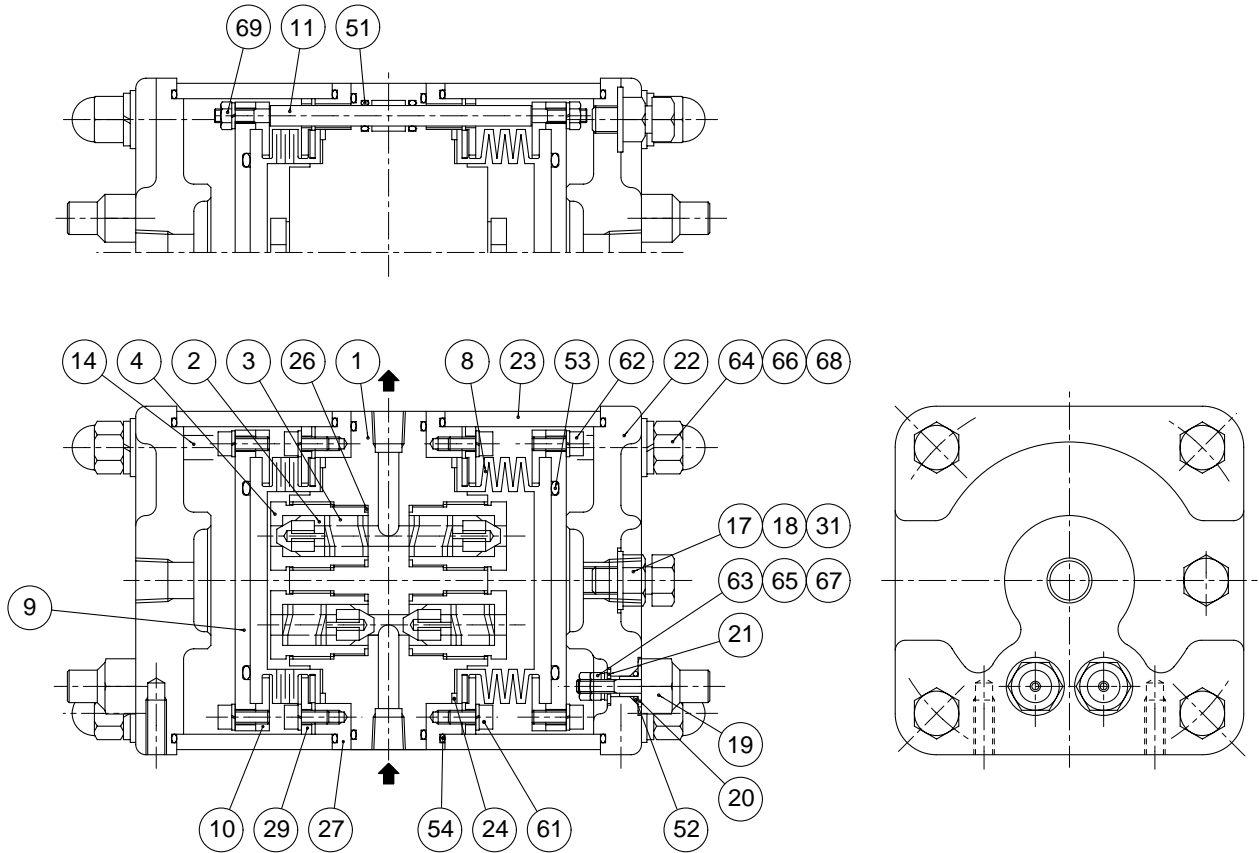

No.	PARTS NAME	Q'TY	MATERIAL	REMARKS	No.	PARTS NAME	Q'TY	MATERIAL	REMARKS
1	PUMP HEAD	1	PTFE		26	VALVE GASKET	4	PTFE	
2	VALVE	4	PTFE		27	PUMP HEAD SETTING PLATE	2	SUS304	PTFE COATED
3	VALVE SPRING	4	PTFE		29	BELLOWS SETTING PLATE	4	SUS304	PTFE COATED
4	VALVE CASE	4	PTFE		31	SEAL NUT	2	SUS304	
8	BELLOWS	2	PTFE		51	O RING	2	FKM	JISB2401P-6
9	BELLOWS PLATE	2	SUS304	PTFE COATED	52	O RING	4	FKM	JISB2401P-7
10	BELLOWS FLANGE	4	SUS304	PTFE COATED	53	O RING	2	FKM	JISB2401G-50
11	PUMP SHAFT	2	SUS304		54	O RING	6	FKM	S-90
14	STUD BOLT	4	SUS304	PTFE COATED	61	HEX. SOCH. CAP BOLT	16	STNLS STL	M4×8
17	PROXIMITY DETECTOR	2			62	HEX. SOCH. CAP BOLT	16	STNLS STL	M4×10
18	DAITHREAD	2	FKM		63	HEX. NUT	8	STNLS STL	M4
19	ELECTRODE	4	SUS304		64	DOMED CAP NUT	8	STNLS STL	M8 PTFE COATED
20	Gasket B	4	PTFE		65	SPRING WASHER	40	STNLS STL	M4
21	Gasket C	4	PTFE		66	SPRING WASHER	8	STNLS STL	M8 PTFE COATED
22	COVER	2	ADC12	PTFE COATED	67	PLATE WASHER	4	STNLS STL	M4
23	CYLINDER	2	A6063	PTFE COATED	68	PLATE WASHER	8	STNLS STL	M8 PTFE COATED
24	BELLOWS GASKET	2	PTFE		69	HEX. NUT	4	SUS304	M4

● FA-40VEW type

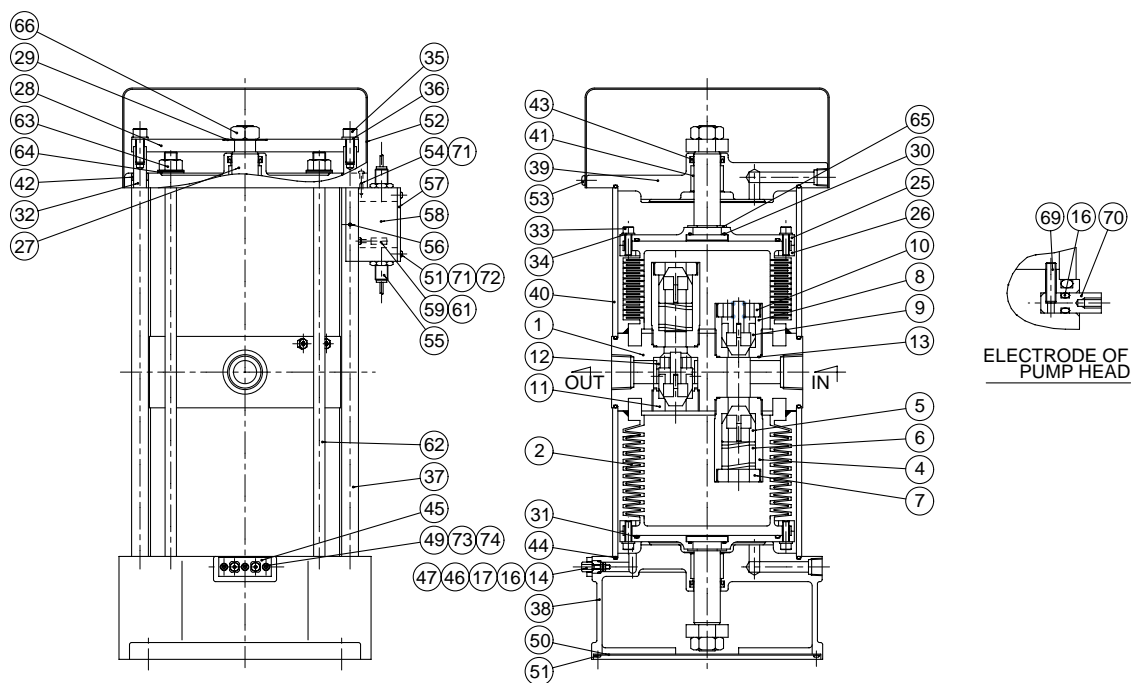

No.	PARTS NAME	Q'TY	MATERIAL	REMARKS	No.	PARTS NAME	Q'TY	MATERIAL	REMARKS
1	PUMP HEAD	1	PTFE		41	BEARING A	2	FILLED PTFE	
2	BELLOWS	2	PTFE		42	BEARING B	4	FILLED PTFE	
4	VALVE CASE A	2	PTFE		43	PACKING	2	FKM	
5	VALVE	2	PFA		44	O RING	4	FKM	
6	VALVE SPRING	2	PFA		45	ELECTRODE SETTING PLATE	1	PVC	
7	VALVE CASE CAP A	2	PTFE		46	GASKET B	2	PTFE	
8	VALVE CASE B	1	PTFE		47	O RING	2	FKM	S-10
9	VALVE B	2	PFA		49	HEX. SOCH. CAP BOLT	3	STNLS STL	M4×10
10	VALVE CASE CAP B	1	PTFE		50	PLATE	1	SUS304	PTFE COATED
11	VALVE CASE C	1	PTFE		51	SCREW	10	STNLS STL	M3×8
12	VALVE CASE CAP C	1	PTFE		52	COVER C	1	SUS304	PTFE COATED
13	VALVE GASKET A	4	PTFE		53	SCREW	4	STNLS STL	M5×8
14	ELECTRODE	2	SUS304		54	SCREW	4	STNLS STL	M3×20
16	O RING	4	FKM	P-3	55	PROXIMITY DETECTOR	2		
17	HEX. NUT	4	STNLS STL	M4	56	SET SCREW	2	STNLS STL	M3×6
25	BELLOWS PLATE	2	SUS304		57	HOLDER COVER	1	PVC	
26	BELLOWS FLANGE	4	SUS304		58	SWITCH HOLDER	1	PVC	
27	PUMP SHAFT A	2	SUS304		59	DETECTING PLATE	1	SUS304	
28	ARM	2	SUS304		61	HEX. NUT	1	STNLS STL	M3
29	CONICAL SPRING WASHER	2	STNLS STL		62	STUD BOLT	4	SUS304	PTFE COATED
30	O RING	2	FKM	S-32	63	HEX. NUT	4	STNLS STL	M12
31	O RING	2	FKM	G-130	64	CONICAL SPRING WASHER	4	STNLS STL	
32	PUMP SHAFT B	2	SUS304		65	STOP RING	4	STNLS STL	E-19
33	HEX. SOCH. CAP BOLT	16	STNLS STL	M6×20	66	HEX. NUT	2	STNLS STL	M20
34	SPRING WASHER	16	STNLS STL	M6	69	SET SCREW	2	STNLS STL	M3×12
35	HEX. SOCH. CAP BOLT	4	STNLS STL	M8×20	70	ELECTRODE HOLDER	2	SUS304	
36	SPRING WASHER	4	STNLS STL	M8	71	SPRING WASHER	8	STNLS STL	M3
37	SHAFT COVER	2	SUS304	PTFE COATED	72	PLATE WASHER	4	STNLS STL	M3
38	COVER A	1	AC4C-T6	PTFE COATED	73	SPRING WASHER	3	STNLS STL	M4
39	COVER B	1	AC4C-T6	PTFE COATED	74	PLATE WASHER	3	STNLS STL	M4
40	CYLINDER	2	Al	PTFE COATED					

INSTALLATION SECTION

This "Installation Section" must be thoroughly understood by the user before actually installing the pump. Do not start your installation work unless you confirm your understanding of the entire set of descriptions in this section.





1. <i>Before Use (Handling instructions) ..</i>	12
2. <i>Installation, Piping, and Wiring</i>	14
2.1 <i>Installation</i>	15
2.2 <i>Liquid piping</i>	16
2.3 <i>Air piping</i>	19
2.4 <i>Air piping and Wiring</i>	23

1. Before Use (Handling instructions)

For reliable pump performance to suit your application purposes, full safety measures should be taken for the pump unit and the entire system. The following information, including the points to be observed in the handling of the pump, deals with the measures to ensure the safe operation of the system. Please read the description carefully.

To operate this pump, a 5-port solenoid valve and a controller (AC-1 type, FD-1 or SC-1 type) are required. In addition, to enhance system safety, a quick exhaust valve must be installed.

No.	Points to be Observed	Description
1	<ul style="list-style-type: none"> ○ Pump stroke speed Do not run pump exceeding FA-2: 150spm (75 strokes). FA-40: 80spm (40 strokes). 	<ul style="list-style-type: none"> ● If many air bubbles are sucked through pump suction port, pump is put into state of air locked operation & no. of strokes rises to abnormal level. Safety measure should be taken in system so that pump does not run at speed above max. stroke speed. With FD-1 or SC-1 type controller, upper limit of stroke speed can be set.
2	<ul style="list-style-type: none"> ○ Supply air pressure should not exceed 0.392MPa 	<ul style="list-style-type: none"> ● If view of pressure resistance of filter at medium temperature, supply air under as low pressure as possible, for protection of bellows & to ensure safety even when bellows are damaged accidentally. ● Any fluctuation in pressure of supplied air causes change in discharge. Attach reducing valve to stabilize pressure.
3	<ul style="list-style-type: none"> ○ Liquid temp. range 	<ul style="list-style-type: none"> ● Temp. of liquid must be maintained within specified temp. range. 5-100°C
4	<ul style="list-style-type: none"> ○ Prohibited liquids  Caution Following liquids must not be used. <ul style="list-style-type: none"> • Liquids that are easily crystallized • Liquids containing slurry • Solvent naphtha 	<ul style="list-style-type: none"> ● Service life of valve & bellows is shortened with use of liquid that is easily crystallized or contains slurry. Use of such liquids is not recommended. ● If solvent naphtha is used, electrostatic destruction may be generated between fluororesin & liquid, finally producing pinholes.
5	<ul style="list-style-type: none"> ○ Liquids to be handled with care <ul style="list-style-type: none"> • Stripper • Solvent type liquids 	<ul style="list-style-type: none"> ● Some type of strippers may cause cracks in bellows or piping (PFA) at an early stage. (Contact Iwaki for a different guarantee period to be applied for such liquid.) ● Explosion-proof specifications are required to use solvent type liquid. (Contact Iwaki for details.)

No.	Points to be Observed	Description
6	○ When stopping pump operation, first open the pump discharge and then stop pump operation.	<p> Caution</p> <p>Stopping pump without releasing pressure on pump discharge side may result in deformed bellows due to force of pressure remaining on pump discharge side.</p>
7	○ Do not suspend pump operation for a prolonged period without first removing the liquid from the pump chamber.	<p> Caution</p> <p>Suspending pump operation for a prolonged period without removing liquid inside the pump chamber may cause corrosion of the electrode or other parts due to permeation of the liquid's gas content. (Example: Pump operated once a day for a minimum period of 10 minutes.)</p> <p>In such a case, contact Iwaki for special instructions.</p>
8	○ Do not narrow air exhaust port. (Do not use tube of smaller diameter than specified.)	<p> Caution</p> <p>If exhaust port of 5-port solenoid valve is extended to position other than usual specification, & air exhaust port is narrowed, bellows may be deformed by force of supply air resulting from imbalance between discharge side pressure & supply air pressure.</p>
9	○ Do not supply air to both right & left air supply ports when pump operation is suspended.	<p> Caution</p> <ul style="list-style-type: none"> ● If air is supplied simultaneously to two air chambers on right & left sides while pump operation is suspended, bellows are pressurized & will finally be deformed. ● Be especially careful when using double solenoid electromagnetic valve, because some types of valve cause simultaneous pressurization of two air chambers while valve is not conducting.
10	○ Do not close the secondary-side air valve upon stopping the pump.	<p> Caution</p> <ul style="list-style-type: none"> ● If the secondary-side air valve on the liquid line is closed upon stopping the pump, the resulting residual pressure in the bellows may cause a deformation of the bellows. ● Note that the secondary-side air valve is kept open except for the purpose of drainage.

■ Other precautions to be taken

[1] Surface temperature of pump

WARNING

Touching the pump or piping whose surface temperature is extremely high due to the circulation of a hot liquid is very dangerous. Always arrange adequate hand-protective measures when engaged in feeding a hot liquid into the pump. The max. pump surface temperature is shown in the table.

Model	Stroke speed	Liquid Temp	Maximum surface temperature when ambient temperature is at 26°C
FA-2	150spm	110°C	53°C
FA-40	80spm		

[2] Noise from pump

Noises are generated from air exhaust or the like during pump operation. Apply sound damping measures as necessary. The level sound generated by pump is shown in the table.

Model	Supply air pressure	Stroke speed	Sound level
FA-2	0.392MPa	150spm	72dB
FA-40		80spm	

2. Installation, Piping, and Wiring

When you feel or notice any danger or abnormal condition during installation and other set-up work, stop the work and go back to the very first step.

WARNING

Make sure no one turns on the power switch while work is being done on the pump. Be sure to turn off the power switch before you start any maintenance/repair work concerning the pump. If the working site is noisy or under conditions of low visibility, you should display a notice which clearly states "POWER OFF (MAINTENANCE)", near the power switch in order to inform other personnel about the situation. Power ON executed by any other person than the operator/service personnel may result in a serious accident. The operator must take special precautions to avoid accidents.

Only the operator/service staff who is adequately trained in safe handling procedures should be in charge of the related electric arrangement and control of the power source. Iwaki takes no responsibility for injury to person or damage to assets which results from a failure to observe this instruction. Consult Iwaki, an Iwaki branch office, or an Iwaki distributor as necessary.

2.1 Installation

[1] Pump installation position

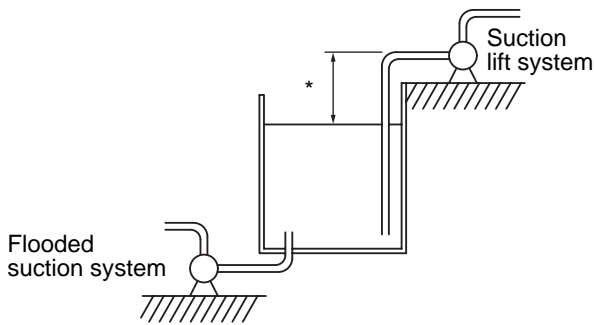

- **In case of flooded suction system**

Set the pump as close to the liquid supply tank as possible.

- ▲ **Caution**

Employ the flooded suction system for feeding a liquid at higher temperatures than room temperature or for a liquid circulation system.

- **In case of flooded lift system**

Set the suction side piping in accordance with the self-priming capacity and as close to the liquid supply tank as possible.

* Self-priming capacity :

FA-2.....1m

FA-40.....2m

- ▲ **Caution**

The self-priming capacity above is based on a pump operation at the max. stroke speed using pure water at room temperature. The suction height differs with the liquid's characteristics, temperature, and suction pipe length. For detailed information, contact Iwaki.

[2] Installation foundation

Select a flat and rigid foundation (such as a chassis) for installation, to avoid twisting motion or vibration.

[3] Direction of pump

Direct the discharge port upward and the suction port horizontally. Use anchor bolts to fasten the pump firmly in position.

[4] Bolt tightening

Tighten the bolts on the housing upon installation by applying the following fastening torque.

Fastening torque for FA-2.....8N·m

FA-40.....5N·m

2.2 Liquid Piping

The standard tubes for both the discharge and suction ports are PFA tubes. Connect the tubes as described below.

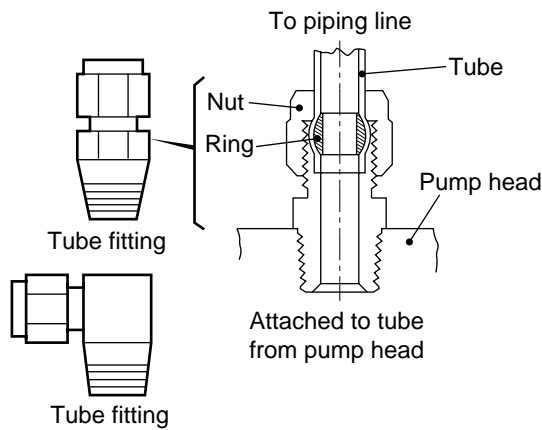

- The diameter of the tube on the piping shall be larger than those of the discharge port and the suction port.

[1] Pump port diameters and materials

The standard material of the pump discharge port and suction port is PFA tube. The applicable tube diameters are as follows.

- * Pump connection
FA-2.....Rc 1/8"
FA-40.....Rc 1"

Use tube fittings with diameters corresponding to those of pump connection. (See the figure on the left.)

[2] Air blow or flush tubing to get rid of foreign matter prior to connecting with the pump.

[3] Tubing connection should be done such that the extra piping load is not applied to the pump. Use pipe supports as necessary to prevent the vibration and heat generated along the piping from reaching the pump.

[4] Pipe joints should be assembled carefully, to prevent liquid leakage, air leakage, and air suction.

[5] Standard couplings may be used in the piping. However, they must be designed to be reliable against leakage in such operations as high-temperature feeding or heat cycle operation.

2.2.1 Points to be observed in suction pipe arrangement

[1] Basically the suction pipe should be large in diameter, short in length, and in the flooded suction condition. In the case of a suction lift system, determine the height according to the self-priming capacity of the pump.

- * The suction height differs with the liquid's characteristics, temperature, and suction pipe length. For detailed information, contact Iwaki.

[2] To block the entrance into the bellows of solid particles such as wafer fragments or the like, install a filter or strainer on the suction pipe. Select a filter or strainer which has a low piping resistance.

⚠ CAUTION

Fragments of damaged wafer chip inside the pump may get stuck in the bellows and eventually cause damage. If solid matter clogs the pump valve, the discharge volume may be affected with the normal checking function disabled.

[3] When installing a valve on the suction pipe, select a valve with an orifice larger than the inner diameter of the said pipe. A smaller orifice may result in a larger suction piping resistance or an increased chance for the valve to be clogged with a crystallized substance. Make sure to keep the valve open during pump operation.

 **CAUTION**

Operating the pump with the valve on the suction pipe increases the pressure inside the bellows to deform the bellows inwardly.

2.2.2 Points to be observed in discharge pipe arrangement

[1] The pump discharge load increases with the length of the discharge pipe or the number of bends along the pipe. In order to decrease the load install a damper which prevents pulsation.

[2] When installing a valve in the discharge pipe, select a valve with an orifice whose diameter is larger than that of the inner diameter of the pipe. A valve with a smaller diameter may increase the discharge piping resistance or easily be clogged with crystallized substance. Keep the valve open when the pump is in operation. Do not close the valve until the discharge pressure reaches 0 Pa after the pump is stopped.

 **CAUTION**

Do not close the valve upon stopping the pump. The resulting impactive pressure may deform the bellows.

[3] A filter must be selected to meet the pump type.

Filtering area, grain-removing performance, and flow characteristics should be taken into consideration in selecting the filter. A desired flow rate may not be achieved if the selection is wrong.

 **CAUTION**

The filter should be dampened well before running operation liquid. A desired flow rate may not be achieved if the filter is not dampened well.

The filter dries out if the operation liquid is not supplied for a long time. Make sure to dampen the filter prior to pump operation. Read the instruction manual of the filter for the details.

[4] The piping should be designed in a manner that no residual pressure results on the discharge side upon stopping the pump.

(For example, filter air elimination shall be set full open or a return circuit shall be employed to remove residual pressure.)

 **CAUTION**

Residual pressure caused on the discharge side upon stopping the pump may deform the bellows.

2.2.3 Air elimination measures

When strongly acidic liquid is fed into the reaction tank or such liquid is circulated through a narrow tube bubbles are generated. If such bubbles are mingled in the liquid that is sent to the bellows, the system is put in a state of air locked operation. As a result, the stroke speed increases and smooth liquid feeding is impacted.

For the safe and efficient circulation and feeding of liquid, it is necessary to carry out air elimination and take proper safety measures.

When air enters the bellows and the pump is air locked, the pump stroke speed increases. If the increase is excessive, that is, higher than the specified pump stroke speed, stop the pump or carry out air elimination.

• A plan (flooded suction system)

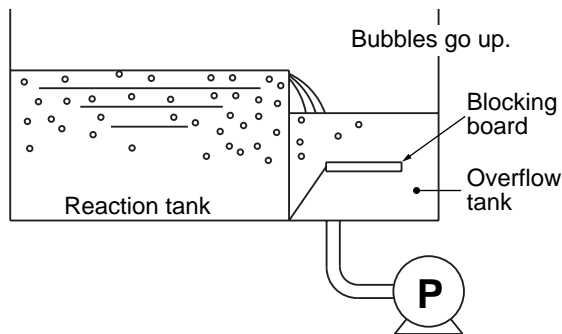

[1] A plan (Bubbles are blocked by means of blocking board)

1. Flooded suction system

A blocking board is set in the overflow tank to separate the bubbles from the liquid, thus eliminating the air content.

2. Suction lift system

A blocking board is set in the lower level in the reaction tank. The top of the suction port tube is positioned under the blocking board so that bubbles are not sucked in together with the liquid.

• A plan (Suction lift system)

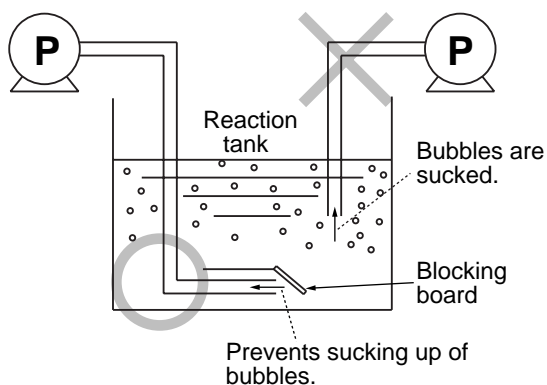

[2] B plan (Automatic air elimination with auto valve installed)

1. Regardless of the occurrence of air locking, continuous automatic air elimination is executed in the entire system. For example, the air elimination process is activated every 2 minutes after the start-up of the pump by opening the auto valve for 10 seconds.

Note 1: Some filters have diameters too small for air elimination. Take the diameter into consideration when selecting a filter.

Note 2: Determine the open period of the auto valve on the basis of the system performance.

• **B Plan (using auto valve)**

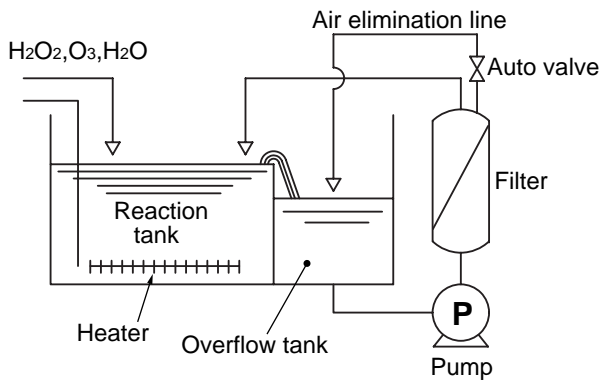

2. If the conditions under which bubbles are mingled remain the same, an air elimination technique which fits well with such conditions may be applicable. For example, if bubbles are generated only when feeding H_2O_2 , open the auto valve to carry out air elimination only when H_2O_2 is fed.

3. Another technique is to install an air detection sensor in the suction port area, so that the auto valve is automatically opened by a signal sent out from the sensor and the air elimination operation is executed.

- Installing another air detection sensor on the discharge side is effective in preventing air from entering in the event of bellows damage.

2.3 Air Piping

 **CAUTION**

- Any supplied air must be instrumentation air which is clean and free from moisture and dust. Water, oil, or dust in the supplied air may lower the performance of the pump.
- The following troubles may occur with FA Series pump if the air supply piping is long and narrow.
 - a. The bellows may be deformed inwardly due to remaining compressed air that is not efficiently released out of the pump air chamber.
 - b. Discharge may be reduced due to failure in increasing the pump stroke speed.

Complete air piping in accordance with the sample arrangement shown in the next page.

2.3.1 Sample air piping

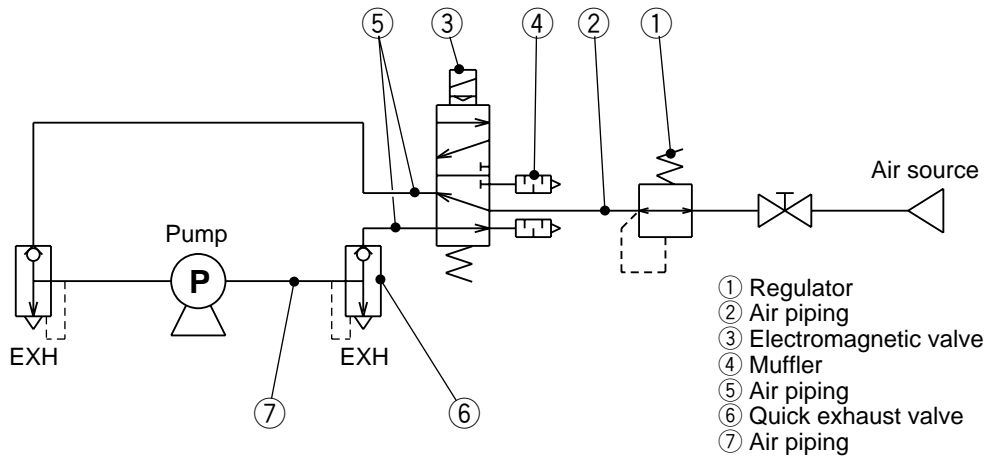

[1] Regulator

Select a regulator on a basis of the air consumption rate of the pump. (Pressure drop shall be less than 20KPa)

⚠ Caution

Set the supply air pressure at 0.392MPa or less.

Each pump shall be provided with an independent regulator.

⚠ Caution

With a single regulator provided to cover plural electromagnetic valves, the electromagnetic valve located far from the regulator may malfunction due to insufficient delivery of pressure.

[2] Air piping

The air pipe between the regulator and the electromagnetic valve should have an inner diameter of 6.5mm (FA-40:10mm) or larger.

[3] Electromagnetic valve

Select a 5-port electromagnetic valve with an effective cross-sectional area of 25mm² or larger. Additionally, the diameter of the port shall be Rc.1/4" (FA-40:Rc 3/8") or larger.

⚠ Caution

When a double-solenoid type electromagnetic valve is to be used, select a 2-position type. Use of a 3-position type may deform the bellows, since the air on both sides is pressured or released simultaneously upon stopping the pump with some 3-position type electromagnetic valve.

[4] Muffler

The muffler shall be installed on the exhaust port of the electromagnetic valve. Select a muffler with an effective cross-section area of 20mm² (FA-40:43mm²) or larger.

[5] Air piping

Select air pipes between the electromagnetic valve and pump or quick exhaust valve as specified in the following table.

Pipe length shorter than 1m	Inner diameter larger than 6.5mm (FA-40:10mm)
Pipe length 1 to 5m	Inner diameter larger than 9mm (FA-40:12mm) or for the use of quick exhaust valve
Pipe length longer than 5m	Contact Iwaki

Note : Both of right and left pipe lengths must be the same.

[6] Quick exhaust valve

As shown in Figure 1, the air exhausted out of the pump flows out of the system via the exhaust port of the electromagnetic valve. (Fig. 1)

Depending upon the type of liquid applied, some permeated gas may mixed into the exhaust air. (The inside of the electromagnetic valve may be corroded by such permeated gas, becoming useless to the system.) In such a case, install a quick exhaust valve between the pump and the electromagnetic valve. The air will be exhausted through the exhaust port of the quick exhaust valve, as shown in Figure 2. (A limited amount of air will be exhausted through the electromagnetic valve.) The quick exhaust valve must be installed in a position close to the pump (within a distance of 1m). (Fig.2)

• Direction of air exhaust

Fig.1 Air Exhaust Without Quick Exhaust Valve

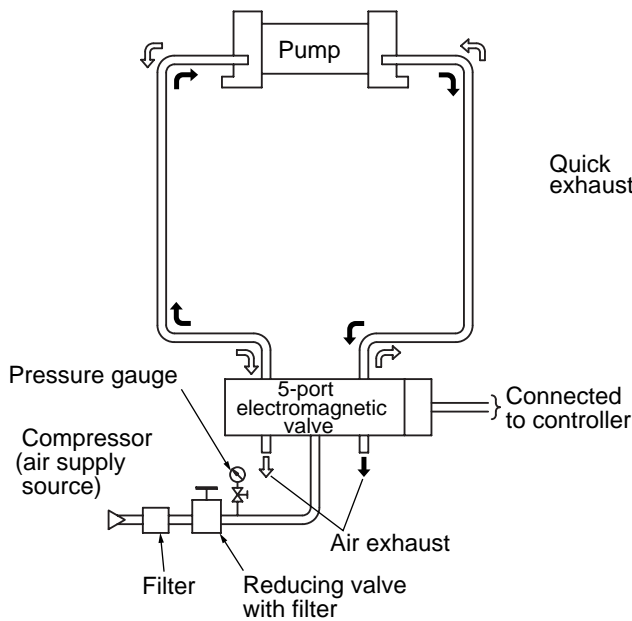
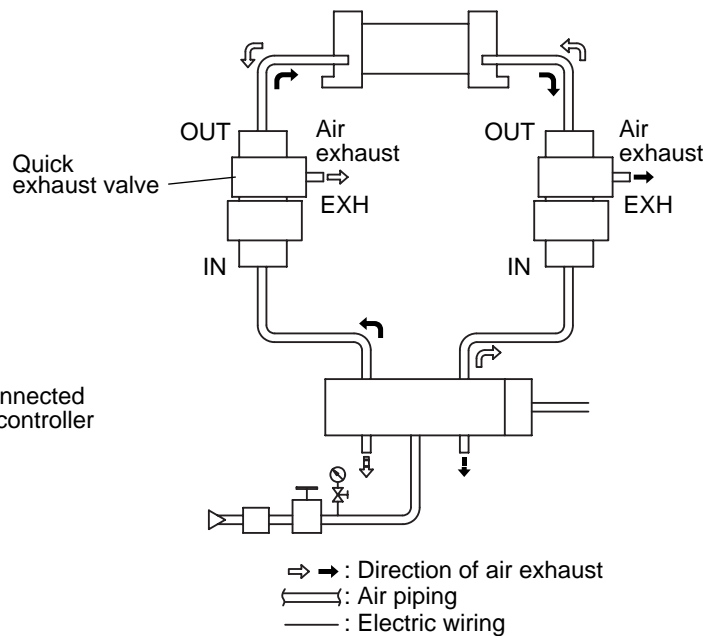

Fig. 2 Air Exhaust With Quick Exhaust Valve



5-port electromagnetic valve : 2 positions, single solenoid

* The quick exhaust valve has the directions of IN, OUT, and EXH. (The direction symbols are stamped on the valve.) The piping should be made as shown in Fig.2.

2.3.2 Points to be observed in air piping

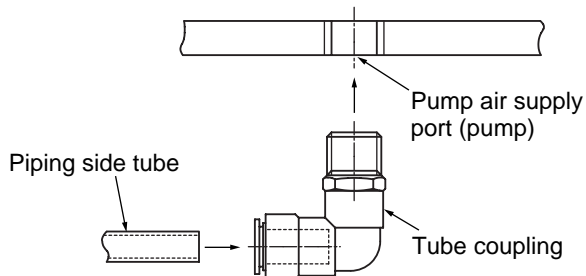

[1] Diameter of pump connection port

The diameter of the connection port on the air supply side is as follows.

* Connection port diameter

FA-2.....Rc 1/4"

FA-40....Rc 3/8"

- The piping side tube should have an inner diameter of 6.5mm (FA-40:10mm) or larger.

[2] Install a relief type reducing valve.

Fluctuation of supply air pressure results in fluctuation of the pump stroke as well as discharge volume. Install a reducing valve to maintain the air pressure at a fixed level.

[3] Install a safety valve.

Install a safety valve to prevent the supply air pressure from exceeding 0.392MPa.

[4] Installation of air exhaust port

The exhaust ports of the air circulation system and the electromagnetic valve must be installed in correct positions so that the exhaust air is released into the open air.

⚠ CAUTION

Narrowing the air exhaust port may block the air exhaust out of the pump. As a result the bellows may be deformed inwardly. Determine the necessary air devices with reference to the sample air piping described in 2.3.1.

[5] Measure to minimize air exhaust

To minimize the noise of air exhaust, connect the exhaust port with a duct or attach a silencer on the exhaust port.

[6] Installation of multiple pumps

The air consumption of pumps (the total consumption by all pumps installed) increases in relation to the compressor capacity. The diameter of the pipe must be determined taking into consideration the total number of pumps.

2.3.3 Effective cross-sectional area

[1] Effective cross-sectional area

In the field of pneumatic device, the term "Effective cross-sectional area" is used to indicate the capacity to allow air to flow freely. When air is sent through a pipe, the air cannot run totally through the actual cross-sectional area of the pipe due to the negative effect of the piping resistance. The de facto cross-sectional area which serves the air flow is called the effective cross-sectional area. (The value increases with the capacity which allows air or fluid to flow freely.)

- * For each effective cross-sectional area value of pneumatic device, refer to the catalog of each device issued by the manufacturer.

[2] Determination of composite effective cross-sectional area

Air devices are connected in series with the pump. It is necessary to determine the composite effective cross-sectional area of the entire system from each effective cross-sectional area of each device. (Determination of the effective cross-sectional area on the air exhaust side.)

Composite effective cross-sectional area is determined from the following formula.

$$\frac{1}{S^2} = \frac{1}{S_1^2} + \frac{1}{S_2^2} + \dots + \frac{1}{S_n^2}$$

S: Composite effective cross-section area

Si: Effective cross-sectional area of each part

Effective cross-sectional area of air device/air pipe: See the catalog issued by each manufacturer.

Quick exhaust valve (QEV-8V): Effective cross-sectional area on the exhaust side (OUT→EXH) is equal to 33mm².

* **Required composite effective cross-sectional area of FA-2 type S=13.2mm² , FA-40 type S=19.5mm² or larger**

Confirm that the composite effective cross-sectional area of the actual air piping is 13.2mm² (FA-40 : 19.5mm²) or larger.

2.3.4 Preventive measures against dew condensation

If condensation is likely to occur in the pipe between the pump and electromagnetic valve, take the following preventive measures.

- Enlarge the diameter of the pipe.
- Arrange a heater system over the piping.
- Feed heated compressed air to the pump. Observe the temperature limits of the pipe joints, electromagnetic valve, and other component parts when heating the pipe or compressed air.

2.4 Air piping and wiring (Connection with AC-1 controller)

■ FA-2 type

Air pulse timer valve is required for the operation of this pump.

When using air pulse timer valve, refer to its instruction manual.

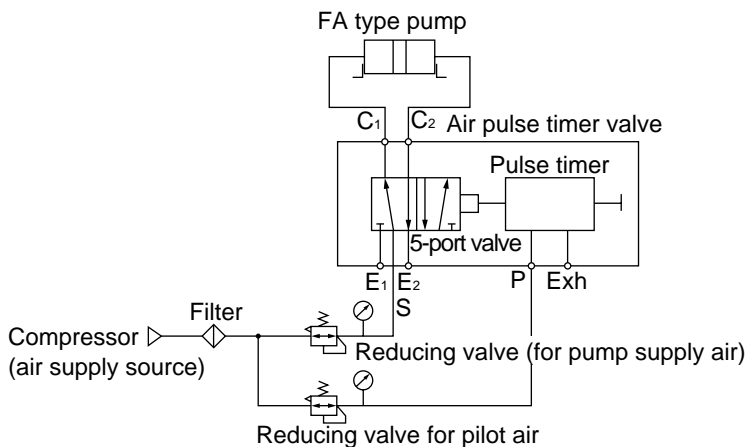

■ FA-2E, FA-40VEW types

A5-port electromagnetic valve and AC-1 controller (FD-1, or SC-1 type) are required for the operation of this pump.

* When using an FD-1, or SC-1 type controller, refer to its instruction manual.

Confirm, first, that the power switch of the controller is set at Off. Then, carry out wiring as shown below, referring to the instruction manual of the applicable controller.

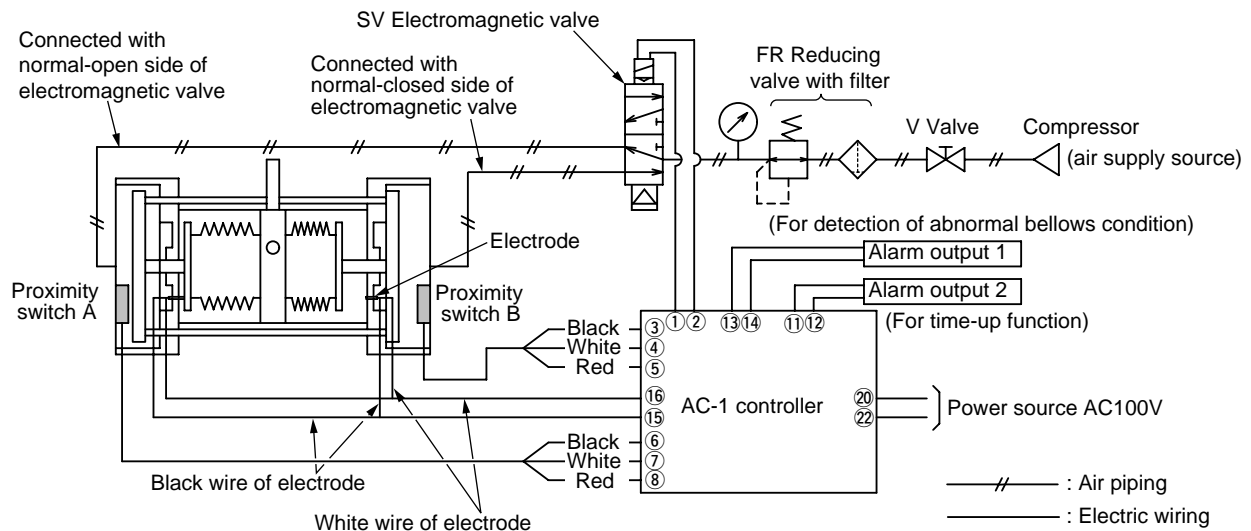

[1] Wiring for proximity detector

⚠ Caution

The proximity detector of the FA series pump have three wires: blue, black, and brown. Carry out the wiring carefully and accurately.

- ▶ Connect the wires (blue, black, and brown) of proximity detector A with terminals no. ⑥, ⑦, and ⑧, respectively, of the controller.
- ▶ Connect the wires (blue, black, and brown) of proximity detector B with terminals no. ③, ④, and ⑤, respectively, of the controller.

* Symbols A and B are arbitrary. The A and B may be interchanged.

Note: The wires should be replaced referring to the following table, when wiring the controller (AC-1 type, etc.).

FA Series	Note
Blue	0V
Black	Output
Brown	Power source (DC10V-DC30V)

⚠ WARNING

A standard proximity detector cannot be used when a flammable liquid such as a solvent is used. An explosion-proof proximity detector must be used in the case of a flammable liquid.

[2] Wiring for electrode

Connect the two wires, which extended from both the right and left sides of the pump, with terminals no. ⑮ and ⑯ of the controller.

* The terminal numbers to be connected with the wires may be interchanged.

WARNING

The use of an electrode is prohibited when a flammable liquid such as solvent is pumped. Sparking of the electrode in a solvent application may cause a fire. Pumping of flammable liquid must employ explosion-proof specifications which may be obtained through consultation with Iwaki or your dealer.

[3] Wiring for 5-port electromagnetic valve

Connect the two wires to terminals no. ① (+) and ② (–) of the controller. Terminals no. ① and ② of the AC-1 type controller have polarity. The electromagnetic valve has no polarity. Some types with a built-in surge killer have polarity, which requires special attention in the connection process.

CAUTION

As a rule, the 5-port electromagnetic valve has no polarity, though there are exceptions. If a 5-port electromagnetic valve with polarity is used, be careful about the +/- polarity in wiring. Note that faulty polarity selection may result in the burning of the valve.

Note:

The air piping of the 5-port electromagnetic valve is divided into the 'normal-open' side pipe and 'normal-closed' side pipe. The 'normal-open' side should be installed on the proximity detector A side and 'normal-closed' on the proximity detector B side. The pump does not run if the above connection is incorrect. To run the pump, interchange the air piping of the 5-port electromagnetic valve or interchange the wires of proximity detectors A and B.

[4] Wiring for alarm output 1

Connect with terminals no. ⑬ and ⑭ for the use of the detection of damaged bellows.

* Please refer to the AC-1 Controller Instruction Manual for details.

- Operating mechanism

If the bellows are damaged while the power switch is on, and the leaked liquid causes the electrode lead wires on either the left or right side to conduct electrically, the controller will be activated to turn the 5-port electromagnetic valve off (and stop the pump). Then, the red LED (bellows abnormality indicator lamp) on the controller will turn on. Simultaneously, the alarm will be generated externally.

[5] Wiring for alarm output 2

Connect with terminals no. ⑪ and ⑫ for the use of the time-up function.

* Please refer to the AC-1 Controller Instruction Manual for details.

- Operating mechanism

Alarm output 2 (Time-up function with AC-1 type controller)

If the time set in the timer is exceeded due to suspended operation or reduced stroke number of the pump, the time-up indicator [Time Up] (yellow) will turn on. Simultaneously, the alarm will be generated externally.

2.4.1 Connection with SC-1 controller

The SC-1 controller should be arranged as shown below. For details, refer to the instruction manual of the SC-1 controller.

Fig. 3 Connection Diagram for SC-1

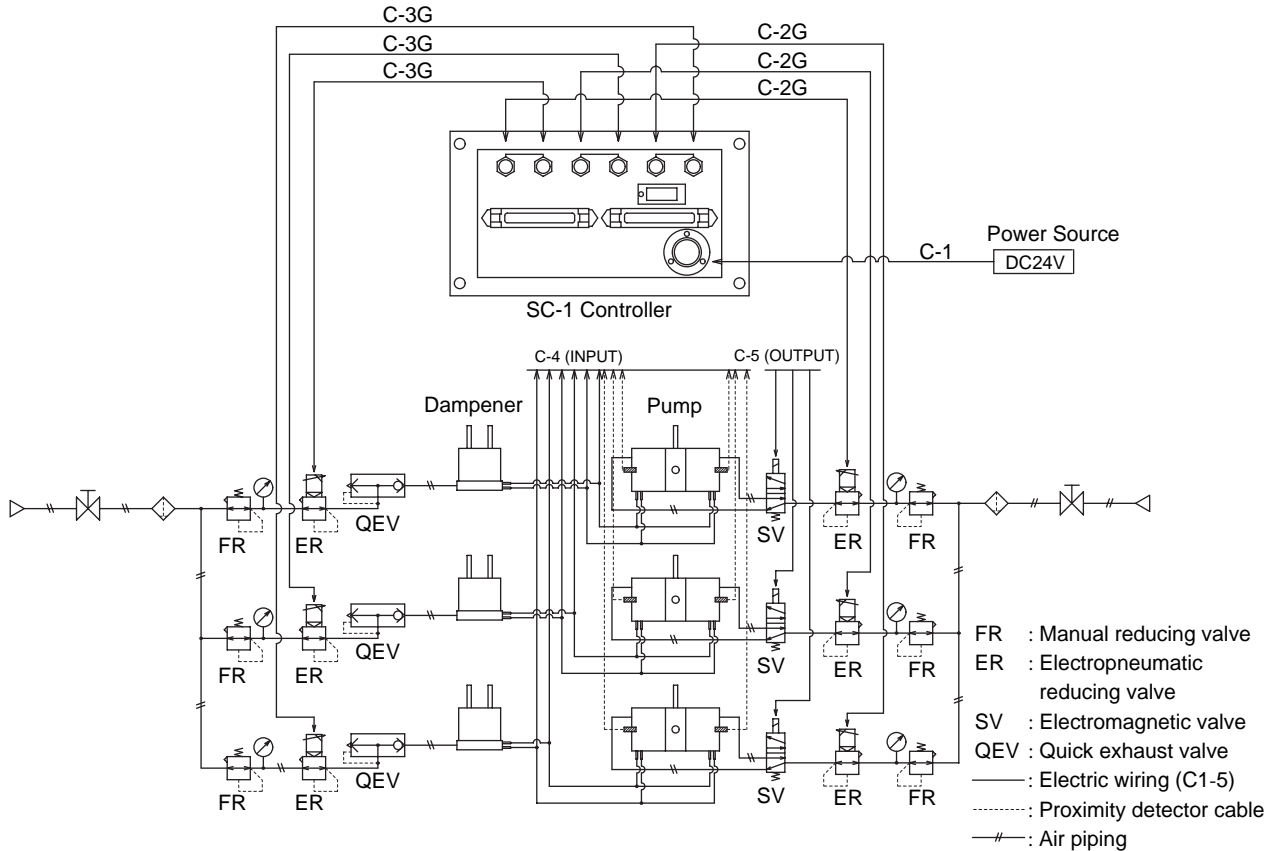

2.4.2 Wiring instructions

[1] Wires

Wires (approximately 2 m) of the proximity detector and lead wires of the electrode are provided with the pump. However, no other connection wires are attached with the product. Obtain the wires required for wiring the controller and 5-port electromagnetic valve in accordance with the following table.

Wire Application	Power Specification
For controller power	115V, 0.24A or above
For connecting 5-port electromagnetic valve & controller	24V, 0.24A or above

[2] Extension of electrode wire

Control the resistance valve to 5kΩ or lower, including the attached lead wire. Any resistance larger than 5kΩ may result in inability to stop the pump. (Because detection by the auto-stop alarm will not be available due to the valve in excess of the detection range of the controller when the bellows is damaged.)

[3] Wiring of proximity detector

Separate the wires of the proximity detector from the power line or other high-voltage cable. They should not be installed in the same duct or in the same cable tube, otherwise the switch may malfunction. When extending the wire, if it is not extended beyond 30m, use a wire of 0.3mm² or above. If the extension is for more than 30m, use a wire a conductive resistance of 100Ω/km or less.

OPERATION SECTION

Pump operation shall be limited to the range covered by and described in this instruction manual. Use of the pump in a different method or procedure that is not described in this instruction manual is prohibited. Iwaki takes no responsibility for injury to person or damage to assets which results from a failure to observe this instruction. Contact Iwaki, an Iwaki branch office, or an Iwaki distributor as necessary.

1. <i>Preparation</i>	29
2. <i>Pump Operation</i>	29
2.1 <i>Starting pump</i>	29
2.2 <i>Stopping pump</i>	30
2.3 <i>Adjustment of discharge capacity</i>	30
3. <i>Points to Be Observed in Operation</i>	30

1. Preparation

Carry out the following preparatory steps when starting the pump operation for the first time after installation or after a long-time suspension of the pump operation.

[1] Confirm that the electric wiring has been conducted correctly. (Wiring for proximity detector and electromagnetic valve.)

 **CAUTION**

Wrong wiring may cause the proximity detector to burn.

[2] Confirm that the air piping has been conducted correctly. Check also for loosened couplings.

[3] Confirm that the pump has been fixed in place.

[4] Confirm that there is no loosened coupling along the liquid piping.

[5] Confirm the valves on the suction and discharge piping are fully opened.

[6] Confirm that the tank or bath has been filled with liquid.

 **CAUTION**

Never fail to conduct a trial run with use of pure water. Confirm that the trial run indicates no abnormal condition before starting the practical operation of the pump.

[7] Confirm that the filter has been well dampened.

 **CAUTION**

Follow the description in the instruction manual of the filter.

2. Pump Operation

During the trial run of the pump, wash the unit and piping at the same time. Following is a description of the operation and adjustment of the pump using the AC-1 controller.
(For pump operation using the FD-1 or SC-1 type controller, refer to the instruction manual of the selected controller.)

2.1 Starting pump

[1] Supply air to the pump.

- Set the regulator to a specified supply air pressure.

 **CAUTION**

Set the supply air pressure within 0.392MPa.

- Open the air supply valve.

 **CAUTION**

When determining the degree to open the air supply valve, see to it that the pump stroke speed will not exceed 150spm (FA-40:80spm) even when the pump is operated loadless.

[2] Turn on the power switch of the controller. The pump will start operation and the 'Operation indicator' LED (blue) on the controller will start flashing.

2.2 Stopping pump

[1] Turn off the power switch of the controller.

The pump will stop operation and the 'Operation indicator' LED will go out.

[2] Make sure the discharge-side valve is open upon stopping the pump.

CAUTION

Do not close the discharge-side valve upon stopping the pump.

[3] Make sure the system does not allow residual pressure on the discharge side upon the stopping of the pump.

2.3 Adjustment of discharge capacity

[1] The discharge amount of the pump shall be adjusted by changing the degree of opening the air supply valve as well as the air flow rate.

3. Points to Be Observed in Operation

Pay attention to the following points during operation.

Upon detecting any abnormal condition, stop the pump immediately and refer to "Causes of Troubles and Troubleshooting."

No.	Inspection Point	Remarks
1	Is pump stroke speed at specified level?	Must be 150spm (75 cycles) or below. Note 1.
2	Is air pressure kept normal?	Must be 0.392MPa or below.
3	Is air volume enough?	
4	Is there any lakage in sealed section of air piping or liquid piping?	
5	Is supply air clean?	

Note 1. FA-40:Must be 80spm (40 strokes) or lower.

MAINTENANCE SECTION

 WARNING
--

<p>Handling, maintenance and inspection of the pump shall be limited to the range covered by and described in this instruction manual. Handling of the pump beyond the range covered by this instruction manual is prohibited. Iwaki takes no responsibility for injury to person or damage to assets caused from a failure to observe this instruction. Contact Iwaki, an Iwaki branch office, or an Iwaki distributor as necessary.</p>

1. *Causes of Troubles and Troubleshooting..... 32*
2. *Maintenance and Inspection34*

1. Causes of Trouble and Troubleshooting

(1/2)

Trouble	Causes	Countermeasures	Inspection and check points
Pump does not operate.	Faulty selection of electromagnetic valve Wrong wiring or disconnection in proximity detector Bellows are damaged. Increased discharge pressure in liquid feeling pipe Supply air pressure or air volume is reduced. Malfunction of electrode	① Inspect and repair or replace. ① Inspect and correct wiring. ② Replace if burned.* ① Replace pump head.* (FA-2:bellows) ① Inspect the filter and replace it. ② Discharge-side valve is closed. ① Set back to initial set value. (Reset) ① Wipe the water splashed over the pump body and/or remove the water contained in the air.	a Use a quick exhaust valve if corrosive gas influences. a Check if the three wires are arranged as described in the manual. b Check air piping and wiring. a Check if supply air pressure is lower than the specification. b Check if pump stroke speed is lower than the specification. c Check if liquid temperature is lower than the specification. d Check if residual pressure is removed upon pump stop. e Check if air pipe is narrow and long. f Check if suction pipe is narrowed. a Check filter for clogging or dry-up. b Check if filter is well dampened. a Open discharge-side valve. a Set pressure higher than min. operation pressure for electromagnetic valve. b Secure a diameter and air flow rate in consideration of the number of pumps installed. a. Take preventive measures against water splashes. b. Use sufficiently dry air.
Pump operates but no liquid is discharged.	Valve is clogged with foreign matter (such as fragments of wafer, etc.). Wear of valve or valve seat.	① Replace pump head.* (FA-2:valve) ② Suction-side valve is closed. ① Replace pump head.* (FA-2:valve and valve seat)	a Install pump guard filter or the like on pump suction pipe. a Open suction-side valve. Check if valve route is blocked with crystallized substance.

(Note) The *-marked repair work shall be conducted by Iwaki.

Trouble	Causes	Countermeasures	Inspection and check points
Discharge volume is reduced.	Supply air pressure or air volume is reduced. Increased discharge pressure Valve is clogged with foreign matter. Wear of valve or valve seat Insufficient NPSHa	① Set back to initial set value or review air flow rate. ① Review discharge conditions. ① Replace pump head.* (FA-2:valve) ① Check suction conditions.	a Secure a diameter and air flow rate in consideration of the number of pumps installed. a Check filter for clogging or dry-up. b Check if air is removed from the filter well. c Check if discharge-side valve is open. a Install pump guard filter or the like on pump suction pipe. a Check if suction pipe is narrow and long.
Liquid leaks.	Stud bolt is not fastened as required. Bellows are damaged.	① Fasten the bolt tightly. ① Replace pump head.* (FA-2:bellows)	Fasten the bolt to the specified torque. (The torque is specified in the next section "Periodic Inspection.") a Check if supply air pressure is lower than the specification. b Check if pump stroke speed is lower than the specification. c Check if liquid temperature is lower than the specification. d Check if residual pressure is removed upon pump stop. e Check if air pipe is narrow and long. f Check if suction pipe is narrowed.
Excessive air consumption	Wear of shaft packing	Replace packing.*	
Pump function is not balanced.	Wear of valve or valve seat Faulty selection of electromagnetic valve	① Replace pump head.* (FA-2:valve and valve seat) ① Inspect and repair or replace.	a Set pressure higher than min. operation pressure for electromagnetic valve.
Excessive vibration or noise	Pump stroke speed is high excessively.	① Set pump stroke speed lower than the specification.	a Lower supply air pressure or reduce air flow.

(Note) The *-marked repair work shall be conducted by Iwaki.

2. Maintenance and Inspection

 **WARNING**

● **Wear protectors**

Make sure to wear protective gear (protective goggles, cap, mask, etc.) when carrying out maintenance and inspection work.

● **Release pressure out of piping**

Residual pressure in the piping may force the liquid and cause an unexpected accident. Release the residual pressure before starting the work.

● **Power OFF**

Make sure no one turns on the power switch while work is being done on the pump. Be sure to turn off the power switch before you start any maintenance/repair work concerning the pump. If the working site is noisy or under conditions of low visibility, you should display a notice which clearly states "Power OFF (Maintenance)" near the power switch in order to inform other personnel about the situation.

Power ON executed by any other person than the operator/service personnel may result in a serious accident. The operator must take special precautions to avoid accidents.

2.1 Periodic inspection

[1] Check if the stroke speed is not lowered. (This should be done at least once a month.)

The stroke speed may be lowered if an air leakage is caused and the air consumption increases. Such a condition may be attributed to the wear of the shaft packing. Replace the packing as necessary.

* This repair work shall be conducted by Iwaki.

[2] Check if the bolt on the housing is loose. (This should be done at least once a month.)

Release the discharge-side pressure first. Then stop the pump and wait until the pump temperature is lowered to room temperature to tighten the bolt slowly and carefully.

Fastening torque for FA-2.....8N·m

FA-40..... 5N·m

[3] Inspection of valve ass'y and Bellows (Inspect more than once a year.) Valve ass'y and bellows are expendable parts. (Life of these parts are depend on liquids and/or operating conditions.)

When pump performance is reduced, or operating period exceed recommended replacing time.

* This repair work shall be conducted by Iwaki.

[4] Operation of the pump after a long suspension

Supply air to the pump (approx. 0.392MPa) and confirm there is no air leakage from the pump discharge port before restarting the pump.

Repair Service

■ Repair

In case something unusual comes to your notice while you are using the pump, stop operation immediately and check whether anything is out of order. (Refer to the chapter on "Causes of Trouble and Troubleshooting".)

[1] For repair work, please contact us or the dealer with whom you placed your order.

[2] Before requesting repair, peruse this instruction manual again and recheck the product.

[3] When you request repair, the following information is needed:

- ① Model code and manufacturing number
- ② Period of use and conditions under which the product has been used.
- ③ Details of the problem

In the event you return your pump, please ship it only after thoroughly washing the inside to prevent residual liquid from flowing out in transit, which is very dangerous.



IWAKI CO.,LTD. 6-6 Kanda-Sudacho 2-chome Chiyoda-ku Tokyo 101-8558 Japan
TEL:(81)3 3254 2935 FAX:3 3252 8892(<http://www.iwaki-pumps.co.jp/>)

()Country codes

Germany	: IWAKI EUROPE GmbH	TEL: (49)2154 9254 0 FAX:2154 1028	Singapore	: IWAKI Singapore Pte. Ltd.	TEL: (65)763 2744 FAX:763 2372
Italy	: IWAKI Italia S.R.L.	TEL: (39)02 9903931 FAX:02 99042888	Indonesia	: IWAKI Singapore (Indonesia Branch)	TEL: (62)21 392 8288 FAX:21 392 8088
Denmark	: IWAKI Pumper A/S	TEL: (45)48 24 2345 FAX:48 24 2346	Malaysia	: IWAKIm Sdn. Bhd	TEL: (60)3 703 8807 FAX:3 703 4800
France	: IWAKI France S.A.	TEL: (33)1 69 63 33 70 FAX:1 64 49 92 73	Taiwan	: IWAKI Pumps Taiwan Co.,Ltd.	TEL: (886)2 2776 5900 FAX:2 2740 2812
Switzerland	: IWAKI (Schweiz) AG	TEL: (41)32 3235024 FAX:32 3226084	Thailand	: IWAKI (Thailand) Co.,Ltd.	TEL: (66)2 322 2471 FAX:2 322 2477
U.K.	: IWAKI PUMPS (UK) LTD	TEL: (44)1743 231363 FAX:1743 366507	Hong Kong	: IWAKI Pumps Co.,Ltd.	TEL: (852)2 607 1168 FAX:2 607 1000
Sweden	: IWAKI Sverige AB	TEL: (46)8 511 72900 FAX:8 511 72922	China	: IWAKI Pumps Co.,Ltd. (Shanghai office)	TEL: (86)21 5234 0776 FAX:21 5234 0775
Finland	: IWAKI Suomi Oy	TEL: (358)9 2742714 FAX:9 2742715	China	: IWAKI Pumps Co.,Ltd. (Beijing office)	TEL: (86)10 6262 6678 FAX:10 6262 6551
Austria	: IWAKI (Austria) GmbH	TEL: (43)2236 33469 FAX:2236 33469	China	: IWAKI Pumps Co.,Ltd. (Guangzhou office)	TEL: (86)20 8130 0605 FAX:(86)20 8130 0601
Norway	: IWAKI Norge AS	TEL: (47)66 80 66 86 FAX:66 80 66 87	Australia	: IWAKI Pumps Australia Pty. Ltd.	TEL: (61)2 9899 2411 FAX:2 9899 2421
Holland	: IWAKI Holland B.V.	TEL: (31)297 241121 FAX:297 273902	U.S.A.	: IWAKI WALCHEM Corporation	TEL: (1)508 429 1440 FAX:508 429 13864
Spain	: IWAKI Iberica Pumps,S.A.	TEL: (34)943 630030 FAX:943 628799			
Belgium	: IWAKI Belgium n.v.	TEL: (32)1430 7007 FAX:1430 7008			