

Chemical gear pumps G series



Fine ceramic used in internal gear

The Iwaki G series chemical pump is the first internal gear pump designed for chemical process applications, in which gears of fine ceramic (SiC and Silicon nitride) are used.

Our pump technology, developed over more than 30 years, has made it possible for Iwaki to equip standard pumps with fine ceramic gears.

Without detracting from any of the advantages of conventional internal gear pumps abrasion resistance, chemical resistance, low-viscosity characteristics and sealing characteristics have been remarkably improved.

In addition to the gland packing/mechanical seal type (Model GX), magnetic drive sealless type (Model GM) are available as standard products for an expanded range of uses.

The G series is an advanced gear pump, capable of dealing with a wide range of industrial processes which continue to increase in sophistication.

Ceramic vs stainless steel gear comparison

Type of gear	Corrosion resistance	Thermal resistance	Seizing resistance	Exfoliation resistance	Abrasion resistance	Coefficient of friction	Impact resistance
Ceramic gear	○	○	○	○	○	○	×
Metal gear	Heat-treated	×	○	△	△	○	○
	Hard coated	△	○	○	×	○	△

Both high viscosity and low viscosity liquids can be handled

When a low-viscosity liquid is handled by a conventional gear pump, "jamming" and "seizing" tend to occur. SiC ceramic gears do not have this problem even when the pump functions at a high speed. Silicon nitride ceramic gears show stable performance in handling high viscous liquids, due to their strength and toughness.

Ability to handle fine slurries

Now that gears and other sliding components including bearings are made of ceramic, the handling of fine slurries hard and soft will not impair the longevity of these pumps. Do not specify GM type for slurry applications.

Magnetic drive type added to standard line

Superior anticorrosive materials such as silicon carbide, silicon nitride, alumina ceramic, PTFE, carbon and stainless steel are used in liquid ends so that all sorts of chemical liquids can be handled. GM is ideal for handling chemical liquids which need strict control on liquid leakage and air contact.

Improved performance characteristics

Performance has been noticeably improved. Ceramic gears make it possible to reduce spaces between parts, therefore outperforming conventional metal gear models.

Performance comparison curves

In the graph below, changes in output at varying discharge pressures are compared between the G series pump and a metal gear pump. The graph shows that the G series, which employs ceramics gears, is far less subject to declining output under high pressure due to its close seal clearance in the gear housing.

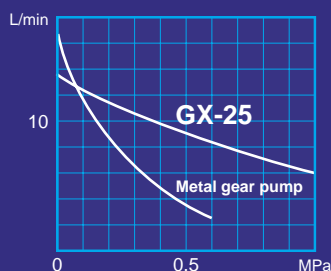

Quiet liquid transfer with less pulsation

Without the pulsation that is common to reciprocating pump and general use type gear pumps, liquid is transferred quietly and smoothly no agitating or foaming.

High self-priming ability

Because the suction port is at the top of the pump, the pump chamber remains full when pump stops working. Self-priming is enhanced at re-start.

Constant flow injection

Regardless of the temperature change, viscous liquid can be handled at accurate flow rate, which can not do with other pumps. As the output is linearly related to rpm, the flow rate is easily controlled by changing speed.



Construction

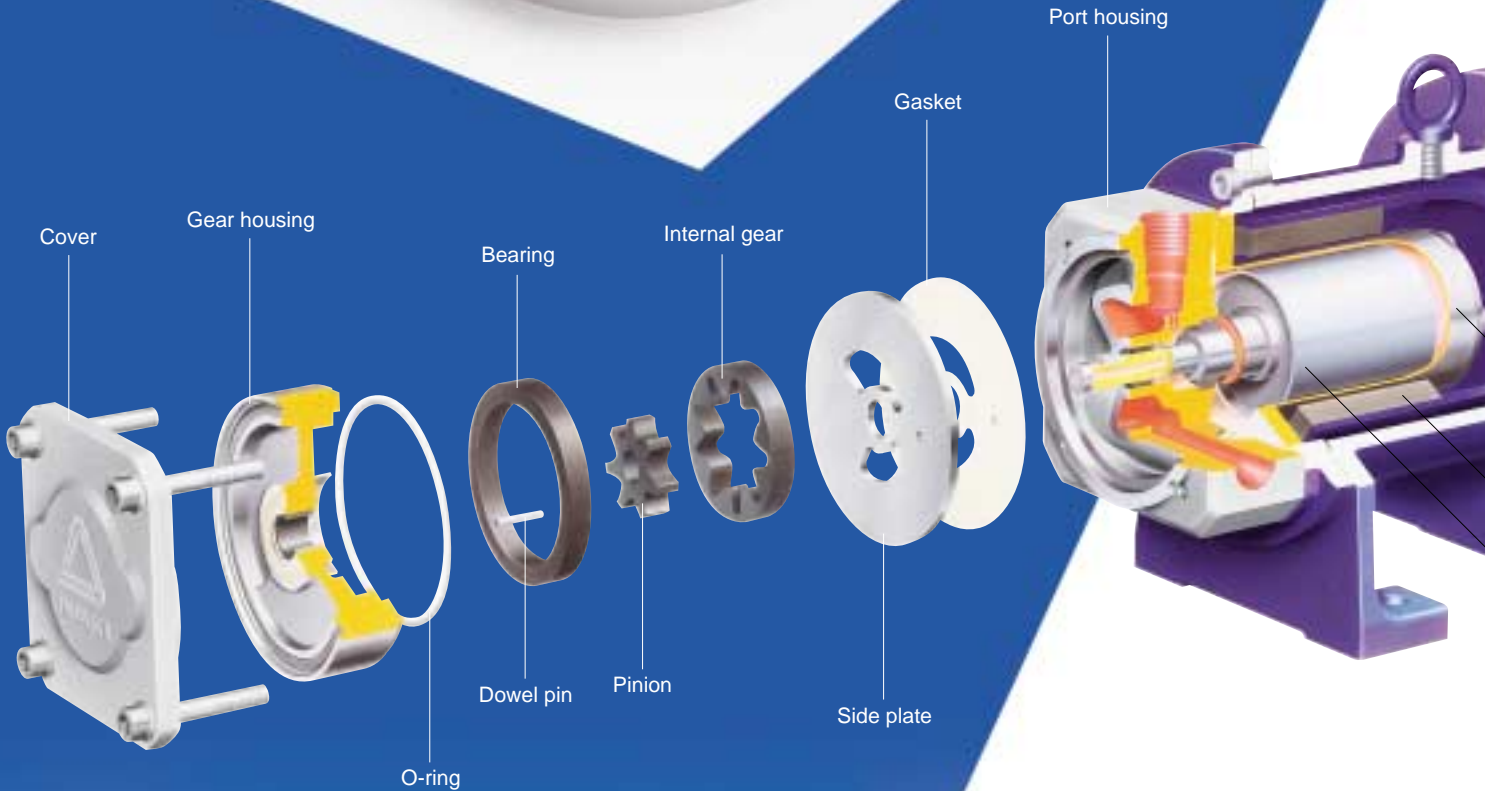

Operating principle



A pinion (drive gear) coupled with a shaft supported by two bearings meshes with an internal gear (driven gear) whose periphery is supported by a strong bearing. Liquid is transferred by a change in the capacity of this meshed portion. In the suction process, the gears are disengaged and a space defined by

the two gears and the casing expands. The liquid is drawn into the space by the negative pressure generated. In the discharge process, their teeth begin to mesh and space defined by the two gears and the casing is reduced to force out the liquid.

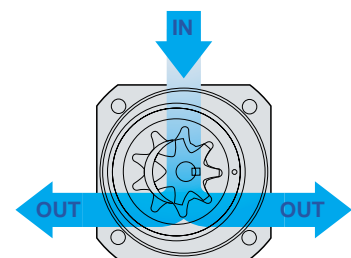

Left or right discharge port selection

GM-15type exploded view

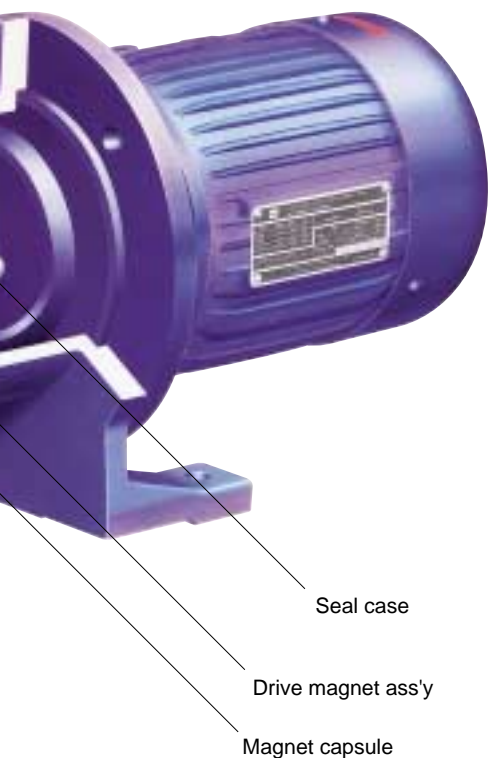

Construction / Wet end materials

GX type

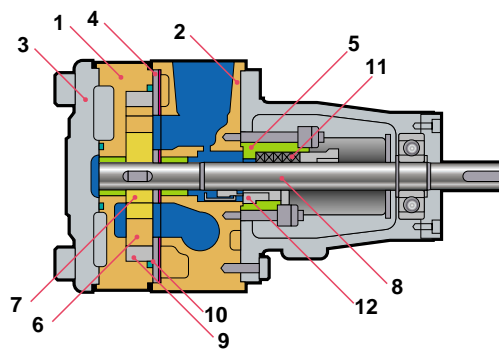

Parts	Wet end materials
1 Gear housing	SUS316
2 Port housing	SUS316
3 Cover	SCS14
4 Side plate	SUS316
5 Seal case	SCS14 or SUS316
6 Internal gear	SiC
7 Pinion	SiC or Si3N4
8 Shaft	SUS630Equi. or SUS316/Cr2O3
9 Bearing	Carbon or SiC
10 Gasket / O-ring	PTFE
11 Gland packing	PTFE
12 Mechanical seal	SUS316/Al2O3/Carbon/PTFE SUS316/SiC/SiC/PTFE

GM type

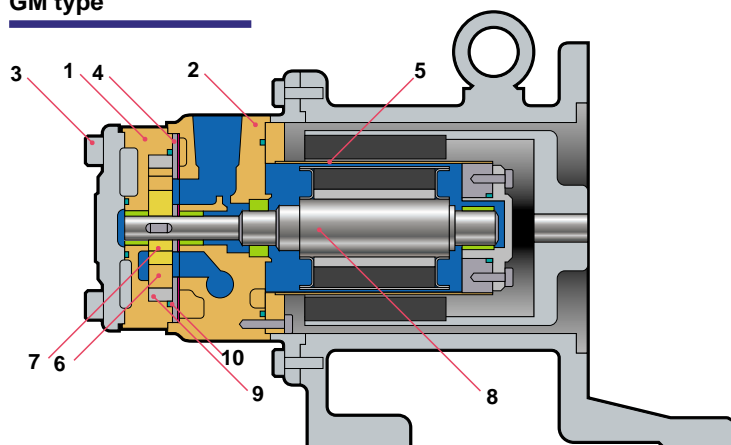

Parts	Wet end materials
1 Gear housing	SUS316
2 Port housing	SUS316
3 Cover	SCS14
4 Side plate	SUS316
5 Seal case	SUS316/SUS304
6 Internal gear	SiC
7 Pinion	SiC
8 Magnet capsule	SUS329J1/SUS316
9 Bearing	Carbon
10 Gasket / O-ring	PTFE

Identification codes

GX-15SKKG-04MC-T

1 2 3 4 5 6 7 8 9 10

1. Pump type	X : Gland packing or mechanical seal M : Magnetic drive	
2. Pump size	12 : 1.0mL/rev 15 : 3.3mL/rev	25 : 12.8mL/rev 32 : 25.0mL/rev
3. Housing material	S : Stainless steel X*2 : Other materials	
4. Gear material*1	K : SiC/SiC N : Si3N4/SiC X*2 : Other materials	
5. Bearing material	C : Carbon K : SiC	
6. Shaft seal	G : Gland packing seal W : Gland packing seal (Water injection type) M : Mechanical seal (Carbon / Al2O3) C : Mechanical seal (SiC / SiC) O : Magnetic drive (GM type)	
7. Motor output	02 : 0.2kW 04 : 0.4kW	07 : 0.75kW 15 : 1.5kW 22 : 2.2kW 37 : 3.7kW

8. Motor type	M : 4P motor S : 6P motor F : Inverter motor G3 : Geared motor (Reduction ratio 1/3) GM-LJ G5 : Geared motor (Reduction ratio 1/5) GM-LJ H3 : Inverter geared motor (Reduction ratio 1/3) GM-LJZ H5 : Inverter geared motor (Reduction ratio 1/5) GM-LJZ N : Variable speed motor NRXM N3 : Variable speed motor (Reduction ratio 1/3) NRXM N5 : Variable speed motor (Reduction ratio 1/5) NRXM N6 : Variable speed motor (Reduction ratio 1/6) NRXM X*2 : Other motors
----------------------	---

9. Motor specifications	Blank : TEFC, indoor type A : Increased safety, outdoor type B : Explosion-proof, outdoor type C : TEFC, outdoor type
10. Special specifications *2	J : Equipped with heat jacket T : Equipped with torque limiter JT : Equipped with heat jacket and torque limiter DT : Tandem mechanical seal type DD : Double mechanical seal type S : Other special specifications

*1. Pinion/Internal gear *2. Special specifications

Specifications

Model	Discharge per revolution mL/rev	Max. speed rpm	Max. discharge pressure MPa *1	Temp. range °C	Viscosity range mPa·s *2	Vacuum KPa *3	Connections	
							IN	OUT
GX-12	1.0	1800	1.0	0 - 150	0.5 - 10,000	5.3	Rc1/2	Rc3/8
GX-15	3.3						Rc1/2	Rc3/8
GX-25	12.8						Rc1	Rc3/4
GX-32	25.0		Rc1 ^{1/4}	Rc1				
GM-12	1.0		0.7	0 - 80	0.5 - 100		Rc1/2	Rc3/8
GM-15	3.3						Rc1/2	Rc3/8
GM-25	12.8	Rc1				Rc3/4		
GM-32	25.0	Rc1 ^{1/4}				Rc1		

*1. These are maximum values, which vary depending on motor speed and liquid viscosity.

*2. Motor speed and motor output suited to the viscosity of your liquid should be selected.

*3. These are values with clear water at 25°C.

Standard pumps selection table

Model	Viscosity range mPa·s	Pump specifications 50/60Hz		Motor		
		Max. pressure MPa	Max. flow rate L/min			
GX-12	0.5≤viscosity<1	0.3 / 0.36	1.4 / 1.7	4P, 0.2kW		
	1≤viscosity<9	0.47 / 0.57				
	9≤viscosity<200	1.0 / 1.0	0.9 / 1.1	6P, 0.2kW		
	200≤viscosity<1000					
	1000≤viscosity<3000					
3000≤viscosity≤10000	0.7 / 0.7	0.5 / 0.6	4P, 0.4kW, 1/3			
GM-12	0.5≤viscosity<1	0.3 / 0.36	1.4 / 1.7	4P, 0.2kW		
	1≤viscosity<9	0.47 / 0.57				
	9≤viscosity≤100	0.7 / 0.7				
GX-15	0.5≤viscosity<1	0.54 / 0.65	4.7 / 5.6	4P, 0.2kW		
	1≤viscosity<9	0.7 / 0.7				
	9≤viscosity<200	1.0 / 1.0	3.0 / 3.7	6P, 0.4kW		
	200≤viscosity<1000					
	1000≤viscosity<3000					
3000≤viscosity≤10000	0.7 / 0.7	1.7 / 2.0	4P, 0.4kW, 1/3			
GM-15	0.5≤viscosity<1	0.54 / 0.65	4.7 / 5.6	4P, 0.2kW		
	1≤viscosity<30	0.7 / 0.7			1.0 / 1.2	4P, 0.4kW, 1/5
	30≤viscosity≤100					

Model	Viscosity range mPa·s	Pump specifications 50/60Hz		Motor	
		Max. pressure MPa	Max. flow rate L/min		
GX-25	0.5≤viscosity<9	0.7 / 0.7	18.0 / 21.8	4P, 0.75kW	
	9≤viscosity<200	1.0 / 1.0		4P, 1.5kW	
	200≤viscosity<1000		11.8 / 14.2	6P, 1.5kW	
	1000≤viscosity<3000		6.4 / 7.7	4P, 0.75kW, 1/3	
	3000≤viscosity≤10000	0.7 / 0.7	3.8 / 4.6	4P, 0.75kW, 1/5	
GM-25	0.5≤viscosity<30	0.7 / 0.7	18.0 / 21.8	4P, 0.75kW	
	30≤viscosity≤100			4P, 1.5kW	
GX-32	0.5≤viscosity<9	0.7 / 0.7	35.2 / 42.5	4P, 2.2kW	
	9≤viscosity<100				
	100≤viscosity<200				
	200≤viscosity<500		1.0 / 1.0	23.0 / 27.7	6P, 2.2kW
	500≤viscosity<1000				
	1000≤viscosity<3000				
3000≤viscosity≤10000	0.7 / 0.7	12.5 / 15.0	4P, 1.5kW, 1/3		
GM-32	0.5≤viscosity<30	0.7 / 0.7	35.2 / 42.5	4P, 2.2kW	
	30≤viscosity≤100			7.5 / 9.0	4P, 1.5kW, 1/5

The recommended gear materials are K(SiC/SiC) for a viscosity below 200mPa·s and N(Si3N4/SiC) for above 200mPa·s.

For handling liquids containing slurry, sticky liquids, liquids that harden easily, etc., select a model with a torque limiter. Please ask us for information on pumps with torque limiters.

Performance chart

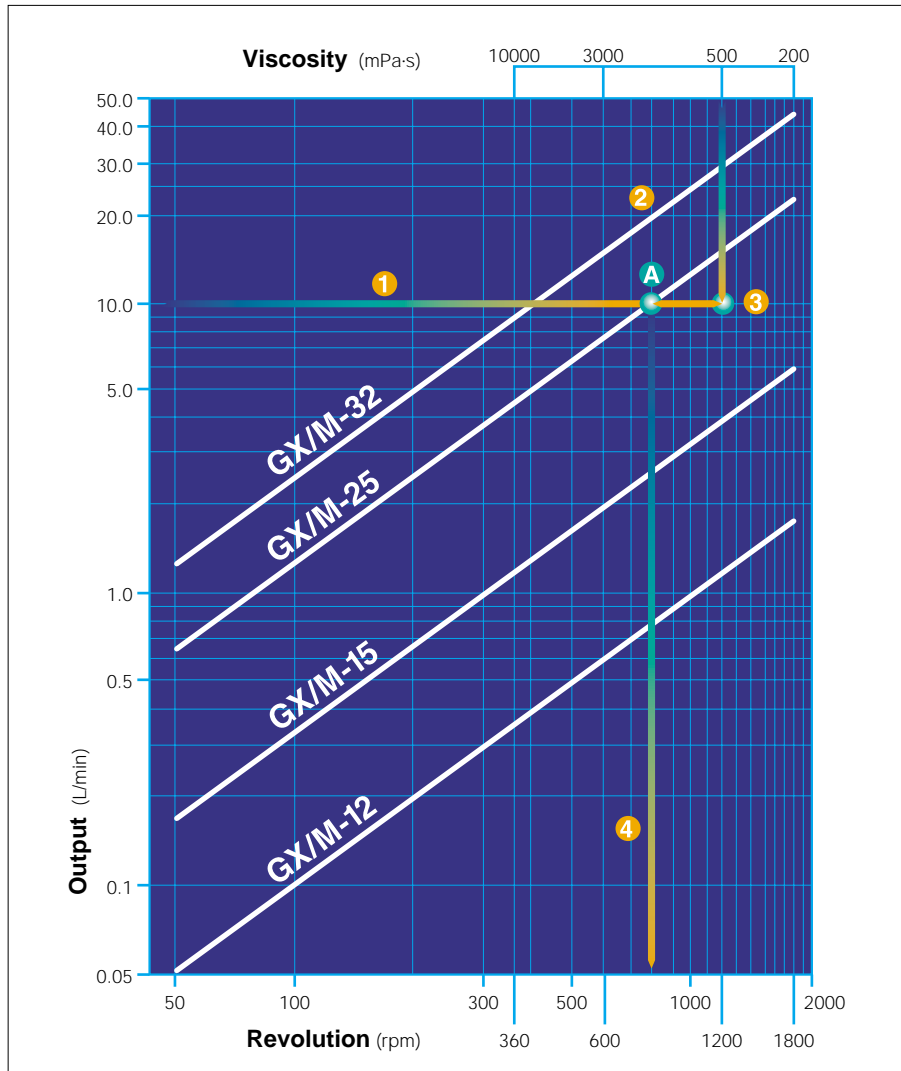

The chart on the left shows output at a discharge pressure of 0MPa. The output changes in proportion to rpm, but rpm should be reduced when pumping viscous liquid. Knowing required output and viscosity, the proper pump/motor rpm can be selected as in the following example.

STEP - 1
Mark the value of your required output (10L/min) on the scale on the left, and draw a horizontal line to the right.

STEP - 2
Mark the value of your viscosity (500mPa·s) on the scale at the top and draw a line downward. In the event your viscosity falls in the middle of two scale lines, select the line on the left (the higher value).

STEP - 3
Extend the intersected point 3 to the left horizontally until intersecting the first pump line (GX/M-25). This point A specifies pump.

STEP - 4
Draw a downward line from A to specify motor rpm 4.

For slurries

For soft slurries, reduce rpm by 75%.
For hard slurries, reduce rpm by 50%.
In principle, only slurries of less than 10 μm in diameter can be handled.
GM type pumps can not handle slurries.

Viscosity-leakage coefficient graph

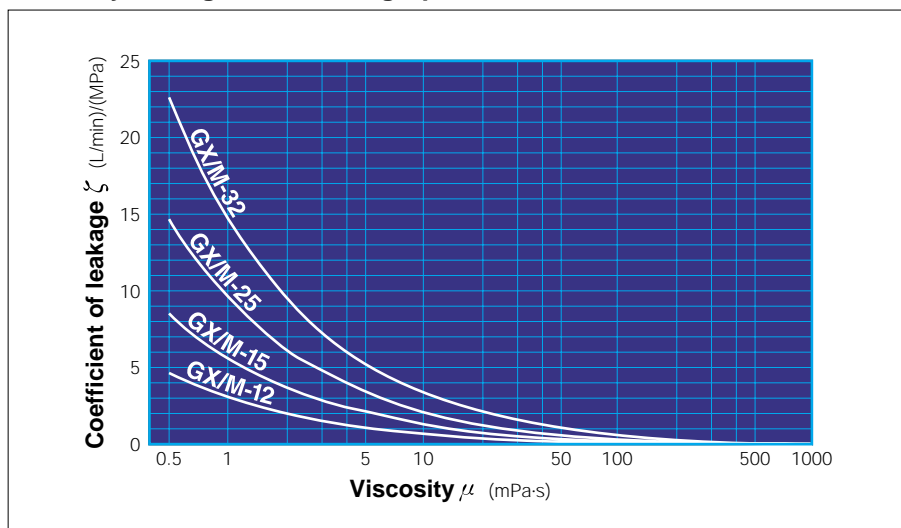

When discharge pressure rises

The lower the viscosity, as discharge pressure rises, the lower the output will be. You can estimate the actual output, in case of a change in viscosity or discharge pressure, from the following formula. (See note below).

$$\zeta = K \times \mu^{-0.65} \quad (1)$$

$$Q_c = q \times N / 1000 - \zeta \times \Delta P \quad (2)$$

Q_c : Estimated output (L/min)
 q : Output per revolution (mL/rev)
 N : rpm
 ΔP : Effective differential pressure (MPa)
 ζ : Coefficient of leakage (L/min)/(MPa)
 μ : Viscosity (mPa·s)
 K : Constant

GX/M-12 : K=3
GX/M-15 : K=5.5
GX/M-25 : K=9.5
GX/M-32 : K=15

For the value of the coefficient of leakage in formula (1), see the viscosity-leakage coefficient graph.

Applications

- Non pulsating constant flow injection of bonding solution in the manufacturing process of copper foil.
- Constant flow spraying of oil laden water (waste liquid burning equipment)
- Constant flow transfer of magnetic slurry
- Constant flow transfer of paint or dye slurry
- Constant flow flocculant injection
- Constant flow injection of paper reinforcing agent
- Spraying of glazing agent in ceramic manufacturing
- Enamel manufacturing

Dimensions in mm

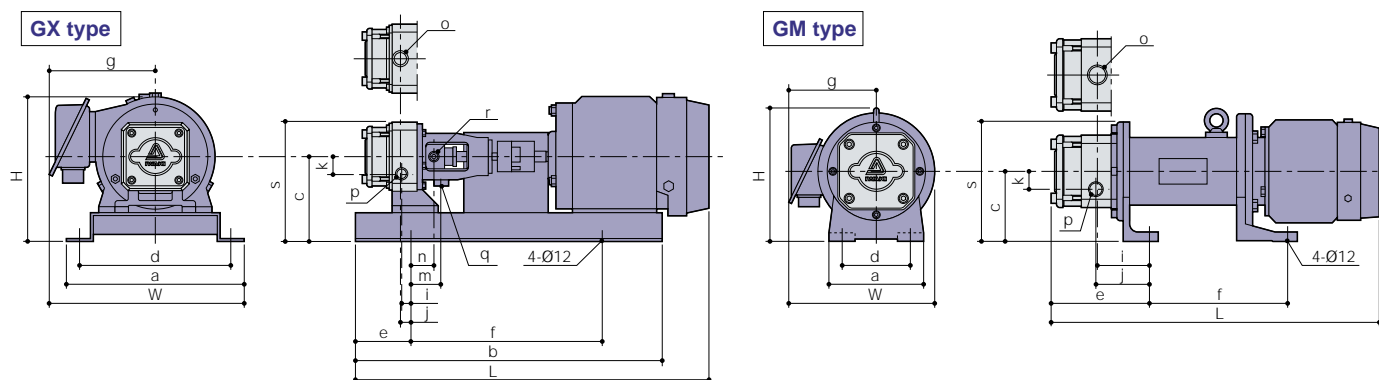

		mm																					
Model	Motor	a	b	c	d	e	f	g	H	i	j	k	L	m	n	W	o	p	q	r	s	Mass	kg
GX-12S GX-15S	02MC	252	440	111.5	222	80	280	142	182.5	13	14	24	442	41	27.5	268	Rc1/2	Rc3/8	Rc1/8	Rc1/8	160.5	17	
	04MC	252	440	111.5	222	80	280	151	186.5	13	14	24	469	41	27.5	277					160.5	19	
	02SC	252	440	111.5	222	80	280	151	186.5	13	14	24	469	41	27.5	277					160.5	19	
	04SC	252	440	120	222	80	280	152	205	13	14	24	501	41	27.5	278			169	26			
	04G □	252	440	111.5	222	80	280	160	219.5	13	14	24	528	41	27.5	286			160.5	24			
GX-12S GX-15S	02MC	128	-	95	98	121	141	142	189.3	65	66	24	423	-	-	222	-	-	-	-	144	21	
	04MC	128	-	95	98	121	141	151	189.3	65	66	24	445	-	-	231	-	-	-	-	144	24	
GX-25S	07MC	266	570	140.5	236	100	360	152	225.5	8	9.5	30	553	49.5	36	285	Rc1	Rc3/4	Rc1/4	Rc1/8	202.5	34	
	15MC	266	570	140.5	236	100	360	166	241.5	8	9.5	30	607	49.5	36	299					202.5	42	
	15SC	266	570	150	236	100	360	172	289	8	9.5	30	648	49.5	36	305			212	49			
	07G □	266	570	140.5	236	100	360	165	265.5	8	9.5	30	606	49.5	36	298			202.5	35			
GM-25S	07MC	160	-	120	120	165	245	152	229.5	83.5	85	30	573	-	-	252	-	-	-	-	182	43	
GX-32S	22MC	340	740	170	300	115	510	210	309	0	0	37	707	80	60	380	Rc1-1/4	Rc1	Rc3/8	Rc1/4	247	69	
	37MC	340	740	170	300	115	510	227	331	0	0	37	724	80	60	397					247	79	
	22SC	340	740	170	300	115	510	227	331	0	0	37	724	80	60	397			247	79			
	15G □	340	740	170	300	115	510	175	337	0	0	37	725	80	60	345			247	74			
GM-32S	22MC	205	-	146	160	190	224	210	288.5	91	91	37	650	-	-	335	-	-	-	-	223	80	